



GIFLEX[®] FLEXIBLE COUPLINGS

SERIES GE-T	page 2
SERIES GE-T SG	16
SERIES GF	22
SERIES GFA	26
SERIES GFAS	34
SERIES FBX	40

TORQUE LIMITERS

TORQUE LIMITERS	46
TORQUE LIMITERS WITH CHAIN COUPLING LCG	51
CHAIN COUPLING WITH KC COVER	52



GIFLEX® GE-T COUPLINGS with FLEXIBLE SPIDER

SERIES GE-T

GE-T COUPLING STANDARD

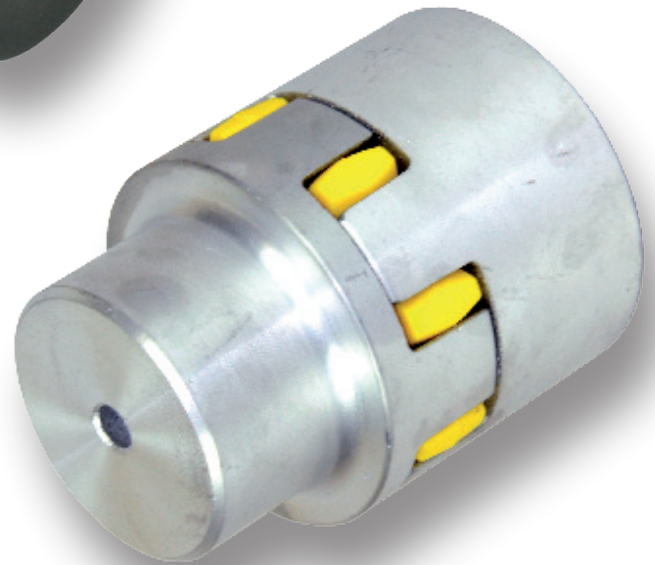

GE-T COUPLING ALUMINIUM

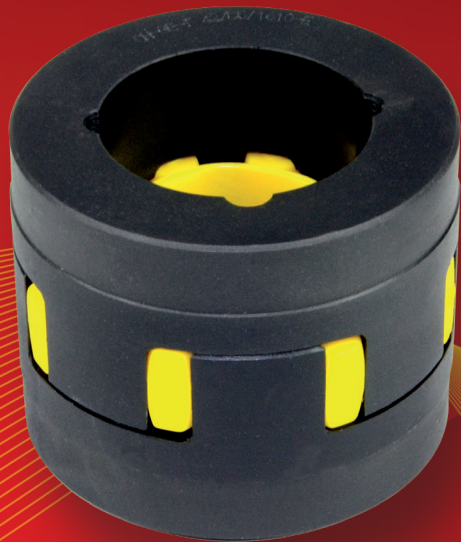

GE-T COUPLING TAPER LOCK®

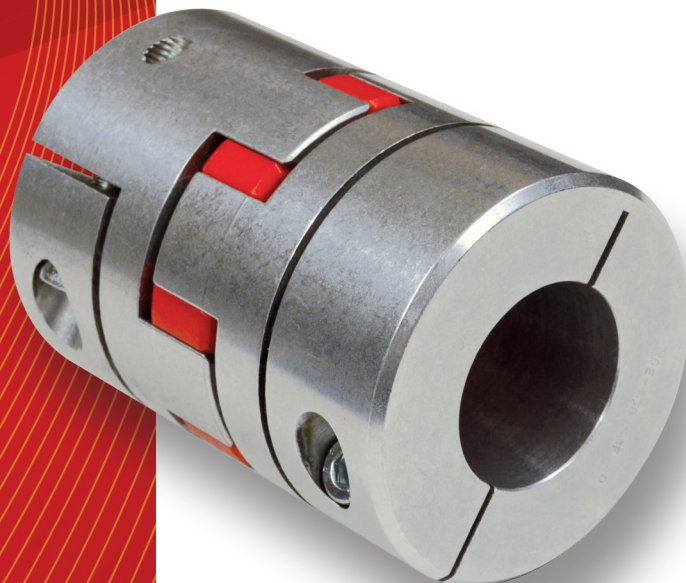

GE-T COUPLING SG

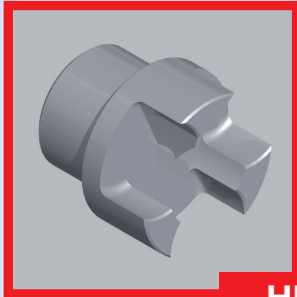

HUB A

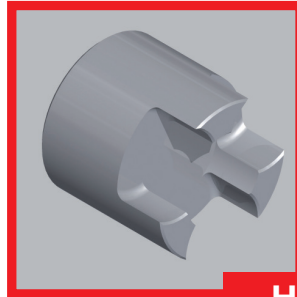

HUB B

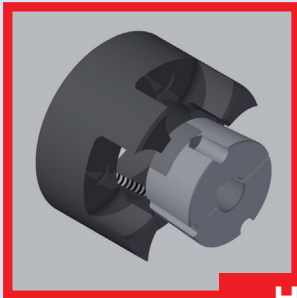

HUB I

internal bushes

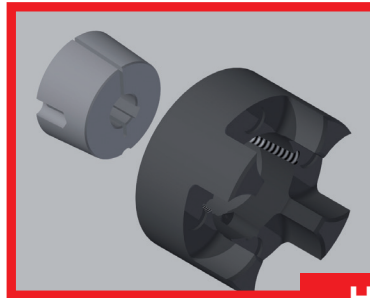

HUB E

external bushes

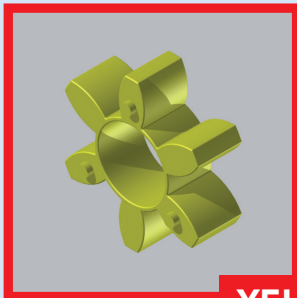

YELLOW POLYURETHANE SPIDER

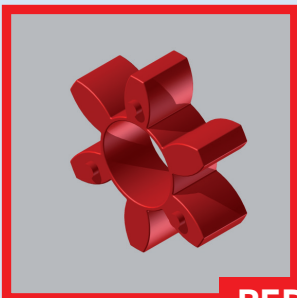

RED ELASTOMER SPIDER

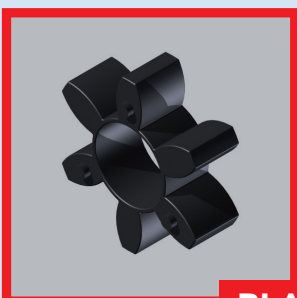

BLACK ELASTOMER SPIDER



INTRODUCTION

Flexible torsion couplings, which are connecting devices between rotating shafts, are designed to ensure shock-free torque transmission and to compensate minor alignment deviations in operation between the shafts in industrial use. The GE-T range of flexible couplings ensures this level of performance and also provides excellent quality thanks to the machining accuracy and the choice of materials used.

The general level of reliability provided by the **GE-T** couplings is ensured by a satisfactory useful working life of the couplings.



GENERAL

The **GE-T** range of flexible couplings represents torsionally flexible mechanical couplings capable of transmitting a twisting moment proportional to the flexible yield of the intermediate component. The couplings must be capable of effectively absorbing possible torsional vibrations due to the load or self-induced, to attenuate impacts and torque peaks during the start-up phase and to compensate minor angular and parallel misalignments between the shafts, however ensuring an acceptable useful working life.

These features and more in general the performance required from the coupling depend almost exclusively on the quality intermediate component.

The choice of the material used to manufacture the coupling is therefore fundamental. The curve that expresses the flexible characteristic of the intermediate component must have a progressive trend (yielding at low torque values and remaining rigid at higher torque values) to ensure operation without jerks at start-up and with a limited torsional yield at steady state conditions.

It is essential for the intermediate component to have a certain flexible hysteresis, proportional to the required absorbing effect that ensures the coupling can efficiently absorb possible torsional oscillations.

Furthermore, the useful working life of the coupling depends on the flexible yield of the material comprising the intermediary component. The physical characteristics described above are frequently in contrast with each other and compared with other basic mechanical and technological parameters. The performance of the intermediary component therefore cannot be adapted to the variety of operating conditions when only one type of material is used and therefore the materials adopted for the flexible ring gear must be differentiated.

A selected thermoplastic elastomer is selected to meet medium level needs in the basic execution.

This refers to an elastomer with medium rigidity, characterised by an optimum internal dampening effect, resistant to ageing, to fatigue, to abrasion, as well as hydrolysis and to the principle chemical agents with special reference to oils and ozone. Operating temperatures lying between -40 °C and + 125 °C with brief peaks of up to 150 °C are permitted in the case of couplings in the base execution.

Alternative mixes capable of meeting every practical need have been designed and are available on request for use in extremely demanding operating conditions, or for needs that exceed average requirements.

OPERATING AND ASSEMBLY CONDITIONS

Operation of the flexible torsion couplings, such as the **GE-T** type or similar couplings is characterized by a proportional feature between the twisting torque and the torsion angle and by the ability to compensate limited angular and radial misalignments. Key features of equal importance, but which are more difficult to interpret are represented by the absorbing factor and natural frequency or resonance.

To qualify its couplings, Chiaravalli Trasmissioni SpA declares permitted twisting torque values correlated to well defined torsion angle values, which has the limiting value of 5 ° C corresponding to the maximum torque value.

This provides a valid guide for the progressive characteristic of the flexible curve.

The maximum permitted values are shown in the case of the angular and radial misalignments, with the warning that these refer to extreme values that cannot be added together (only angular compensation or only radial compensation) and apply to standard operating conditions characterised by the following: operating torque not exceeding the nominal torque, a rotating speed of less than 1,450 r.p.m and coupling temperature not exceeding 40° C.

The maximum rotating speed expressed in r.p.m that corresponds to maximum peripheral speed of 30 m/sec. is indicated for each coupling of the **GE-T** range.

This speed can be achieved with a sufficient safety margin compared to the danger of failure due to centrifugal force stress thanks to the characteristics of the material used.

Class G 2.5 dynamic balancing in compliance with ISO 1940 is recommended despite the fact that the half-couplings are fully machined on both external surfaces, if the actual operating speed exceeds 2.800 r.p.m



COUPLING SELECTION AND SIZING CRITERION

Couplings are sized on the basis of the physical laws of mechanics and the resistance of the materials and also complies on the provisions established in the DIN 740 standards Sheet 2.

the coupling is selected on the basis of the criterion, which establishes that the maximum permitted stress is never exceeded even in the most demanding operating conditions. It follows that the nominal torque declared for the coupling must be compared with a reference torque that takes into account the overloads due to the way the load is exerted and the operating conditions. The reference torque is obtained by multiplying the operating torque by a series of multiplying factors depending on the nature of the load or on the ambient temperature conditions.

LOAD DUE TO NOMINAL TORQUE

The permitted nominal coupling torque TKN must apply for any operating temperature value equal to or greater than the driven side operating torque TLN.

$$TLN = 9549 \frac{(PLn) [Nm]}{nLn}$$

The following condition must be satisfied, where St represents the temperature factor, to take into account overloads due to the operating temperature for the coupling

$$Tk_n > TLN * St$$

START – UP LOAD

The drive motor delivers a drive torque during the start-up transient period which is a multiple of the nominal torque and depends on the way the masses are distributed.

A similar situation occurs in the braking phase therefore, this two phases are characterised by torque impacts that have an intensivity which depends on the distribution of the masses on the drive side MA and on the driven side ML, as well as the frequency of the number of start – ups on which the start – up factor Sz depends.

The static torques for the drive side and the driven side are expressed by the following relationships:

- drive side $TS = TAS * MA * SA$
- driven side $TS = TLS * ML * SL$

MA and ML are assumed to be equal to 1, to first approximation, and if the distribution of the masses is unknown. The SA factor can be assumed as being equal to the relationship between the start – up torque and the nominal torque in the case of drives based on an electric motor.

LOAD CAUSED BY TORQUE IMPACTS

The permitted nominal coupling torque TKN max must be equal to or greater than the start-up torque increased by the temperature factor and by St and by the start-up factor Sz for any operating temperature value.

$$Tk_n \max > TS * St * Sz$$

Consult the CHIARAVALLI Trasmissioni Technical Department for operating conditions that foresee periodic variation or torque inversions, as well as alternate torsional stresses.

SYMBOLS

- Tk n = coupling maximum torque (Nm)
- Tk max = coupling maximum torque (Nm)
- Tk w = torque with coupling inversion (Nm)
- TLN = driven side operating torque (Nm)
- TLs = driven side static torque (Nm)
- TAs = motor side static torque (Nm)
- Ts = plant static torque (Nm)
- PLn = driven side operating power (Nm)
- nLn = driven side rotating speed (r.p.m)
- St = temperature factor
- JA = inertia moment drive site
- JL = exit side
- SA = motor side impact factor
- SL = driven side impact factor
- Sz = start-up factor
- MA = control side mass factor $\frac{JL}{JA+JL}$
- ML = driven side mass factor $\frac{JA}{JA+JL}$

INDICATIVE VALUES FOR ADJUSTMENT FACTORS:

Name	Symbol	Definition
Temperature factor	St.	St. 1 1 1,4 1,8 C° -30° +40° +80° +120° +30°
Start-up Factor	Sz.	Number of start-ups per hour Start-up/hr. 100 200 400 800 Sz. 1 1,2 1,4 1,6
Impact factor	SA/SL	SA/SL minor start-up impacts 1,5 medium start-up impacts 1,8 major start-up impacts 2,2

SERVICE FACTORS:

Load condition	Operating conditions	Type of Drive	
		Electric motor	Diesel engine
UNIFORM	Regular operation without impacts or overloads	1,25	1,5
LIGHT	Regular operations with minor and infrequent impacts and overloads	1,50	2,0
MEDIUM	Irregular operation with medium overloads for a short duration and frequent but moderate impacts	2,0	2,5
HEAVY	Markedly irregular operation with very frequent impacts and overloads and of major intensity	2,5	3,0

GIFLEX® GE-T COUPLINGS with FLEXIBLE SPIDER ACCURATE EXECUTION

TECHNICAL DATA

with a **BLACK SPIDER**
 ELASTOMERIC
 92/94 shore A
 EMPLOYMENT TEMPERATURE - 40° +140°
 USING IN AMBIENT THAT CAN
 BE CONTAMINATED

with a **YELLOW SPIDER**
 POLYURETHAN
 92/94 shore A
 EMPLOYMENT TEMPERATURE - 40° +90°

COUPLING GE-T in ALUMINIUM ALLOY or CAST-IRON

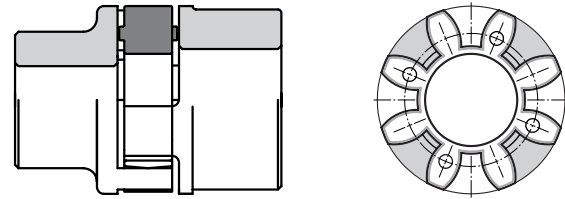
RADIALLY displaced shaft

ANGULARLY displaced shaft

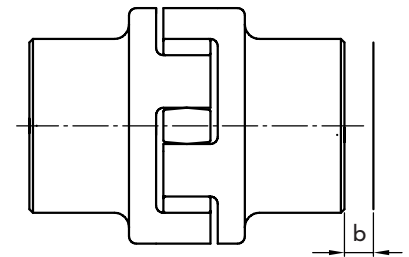
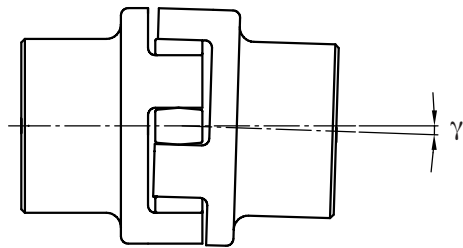
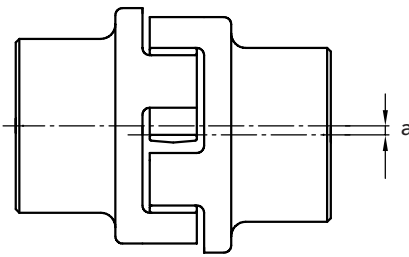
AXIALLY displaced shaft

TECHNICAL DATA

TYPE	MAX R.p.m. n. min. 1	Torsion angle		Spider shore A	Twisting moment (Nm)			Torsional rigidity (kNm/rad)				axial displacement b mm	maximum misalignment	
		Tk n	Tk max		Norm. Tk n	Max Tk max	with inversion Tk w	1,0 Tk n	0,75 Tk n	0,5 Tk n	0,25 Tk n		radial a mm	angular γ°
GE-T 19-24	14000	3°	5°	94	10	20	2,6	0,68	0,57	0,44	0,28	1,2	0,2	1,2°
GE-T 24-32	10600			94	35	70	9	2,19	1,82	1,40	0,90	1,4	0,2	0,9°
GE-T 28-38	8500			94	95	190	25	5,20	4,31	3,32	2,12	1,5	0,25	0,9°
GE-T 38-45	7100			94	190	380	49	10,00	8,30	6,39	4,08	1,8	0,28	1,0°
GE-T 42-55	6000			94	265	530	69	17,00	14,11	10,86	6,94	2,0	0,32	1,0°
GE-T 48-60	5600			94	310	620	81	20,00	16,59	12,77	8,16	2,1	0,36	1,1°
GE-T 55-70	4750			94	410	820	105	21,99	18,25	14,05	8,98	2,2	0,38	1,1°
GE-T 65-75	4250			94	625	1250	163	28,20	23,39	18,01	11,51	2,6	0,42	1,2°
GE-T 75-90	3550			94	1250	2500	330	67,99	56,41	43,44	27,75	3,0	0,48	1,2°
GE-T 90-100	2800			94	2400	4800	624	110,00	91,26	70,27	44,89	3,4	0,50	1,2°



TECHNICAL DATA

With **RED SPIDER**
 THERMOPLASTIC RUBBER
 96/98 shore A
 EMPLOYMENT TEMPERATURE - 30° +140°

COUPLING GE-T in ALUMINIUM ALLOY or CAST-IRON

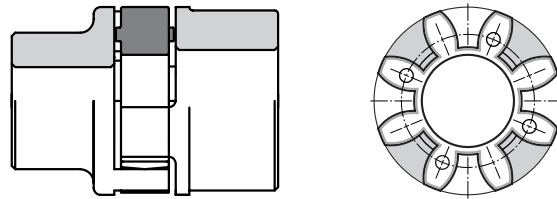

RADIALLY displaced shaft

ANGULARLY displaced shaft

AXIALLY displaced shaft

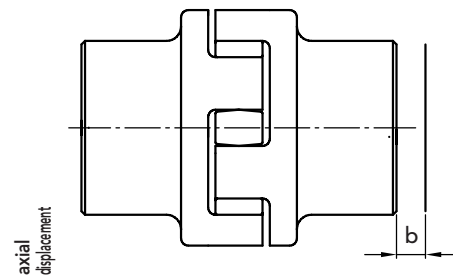
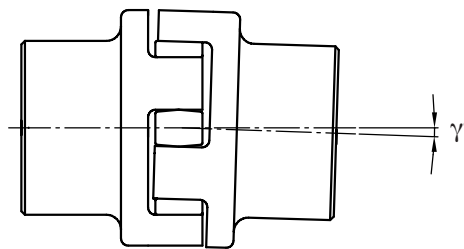
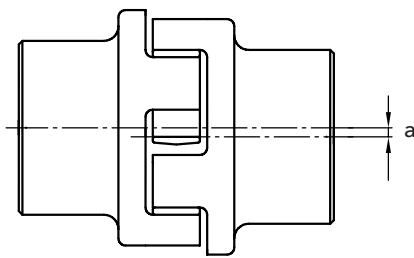

TECHNICAL DATA

TYPE	MAX R.p.m. n. min. 1	Torsion angle		Spider shore A	Twisting moment (Nm)			Torsional rigidity (kNm/rad)				axial displacement b mm	maximum misalignment	
		Tk n	Tk max		Norm. Tk n	Max Tk max	with inversion Tk w	1,0 Tk n	0,75 Tk n	0,5 Tk n	0,25 Tk n		a mm	angular γ°
GE-T 19-24	14000	3°	5°	96	17	34	4,4	1,09	0,90	0,68	0,42	1,2	0,2	1,2°
GE-T 24-32	10600			96	60	120	16	3,70	3,04	2,31	1,44	1,4	0,2	0,9°
GE-T 28-38	8500			96	160	320	42	9,5	7,80	5,92	3,68	1,5	0,25	0,9°
GE-T 38-45	7100			96	325	650	85	29,0	23,8	18,6	11,24	1,8	0,28	1,0°
GE-T 42-55	6000			96	450	900	117	40,5	33,24	25,21	15,70	2,0	0,32	1,0°
GE-T 48-60	5600			96	525	1050	137	48,56	39,86	30,23	18,82	2,1	0,36	1,1°
GE-T 55-70	4750			96	625	1250	163	52,78	43,32	32,86	20,46	2,2	0,38	1,1°
GE-T 65-75	4250			96	940	1880	166	57,5	47,19	35,80	22,29	2,6	0,42	1,2°
GE-T 75-90	3550			96	1910	3850	490	150,0	123,12	93,39	58,14	3,0	0,48	1,2°
GE-T 90-100	2800			96	3600	7200	936	250,0	205,19	155,65	96,90	3,4	0,50	1,2°

AXIS MISALIGNMENTS COMPENSATED with GE-T COUPLING



"GIFLEX®" SERIE GE-T with ELASTIC SPIDER ACCURATE EXECUTION

CAST-IRON GG25

INTERPRETATION CODES

EXAMPLE

- GE-T 19A-24B = HUB A + HUB B**
- GE-T 19A-24B = HUB B + HUB A**
- GE-T 19A-19A = 2 HUB A**
- GE-T 24B-24B = 2 HUB B**

The characteristic size of the coupling is defined by the maximum diameter bore.

STEEL*

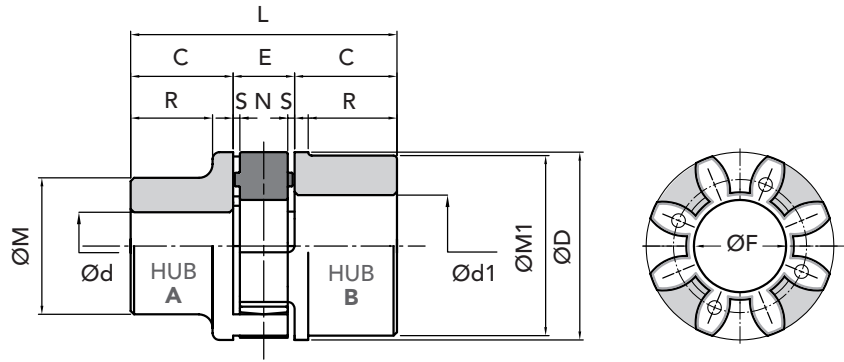

PART NUMBERS

COUPLING TYPE	PART NUMBER		Spider		Polyurethane
	HUB A	HUB B	BLACK	RED	YELLOW spider
	A	B	92/94 shore A	96/98 shore A	92/94 shore A
GE-T 19A-24B*	02201920	02201940	02001910	02001911	02001912
GE-T 24A-32B	02202420	02202440	02002410	02002411	02002412
GE-T 28A-38B	02202820	02202840	02002810	02002811	02002812
GE-T 38A-45B	02203820	02203840	02003810	02003811	02003812
GE-T 42A-55B	02204220	02204240	02004210	02004211	02004212
GE-T 48A-60B	02204820	02204840	02004810	02004811	02004812
GE-T 55A-70B	02205520	02205540	02005510	02005511	02005512
GE-T 65A-75B	02206520	02206540	02006510	02006511	02006512
GE-T 75A-90B	02207520	02207540	02007510	02007511	02007512
GE-T 90A-100B	02209020	02209040	02009010	02009011	02009012

MEASUREMENTS - WEIGHTS

COUPLING TYPE	Ø hub bore		Ø finished bore		measurement in mm normal range										Weight Kg			J Kg cm² hubs A+B
	A	B	Ød max	Ød1 max	C	ØD	E	ØF	ØM	ØM1	N	R	S	L	spider	hub A	hub B	
GE-T 19A-24B*	-	-	19	24	25	40	16	18	30	40	12	19	2	66	0,004	0,18	0,25	0,8
GE-T 24A-32B	-	-	24	32	30	55	18	27	40	55	14	24	2	78	0,014	0,36	0,55	3
GE-T 28A-38B	-	-	28	38	35	65	20	30	48	65	15	27,5	2,5	90	0,025	0,60	0,85	7
GE-T 38A-45B	-	-	38	45	45	80	24	38	66	78	18	36,5	3	114	0,042	1,35	1,65	20
GE-T 42A-55B	-	-	42	55	50	95	26	46	75	94	20	40	3	126	0,066	2,00	2,30	50
GE-T 48A-60B	-	-	48	60	56	105	28	51	85	104	21	45	3,5	140	0,088	2,75	3,10	80
GE-T 55A-70B	-	-	55	70	65	120	30	60	98	118	22	52	4	160	0,116	4,20	4,50	160
GE-T 65A-75B	-	-	65	75	75	135	35	68	115	134	26	61	4,5	185	0,172	6,50	6,80	310
GE-T 75A-90B	-	-	75	90	85	160	40	80	135	158	30	69	5	210	0,325	10,00	10,80	680
GE-T 90A-100B	38	38	90	100	100	200	45	100	160	180	34	81	5,5	245	0,440	14,00	15,80	1590

J inertia torque HUB A+B with bore max Ø

HUB A - B

HUB B - A

HUB A - A

HUB B - B

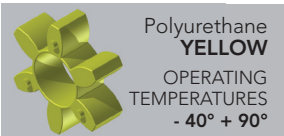
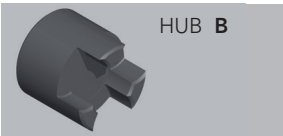
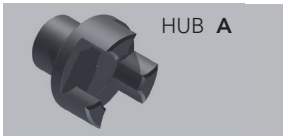
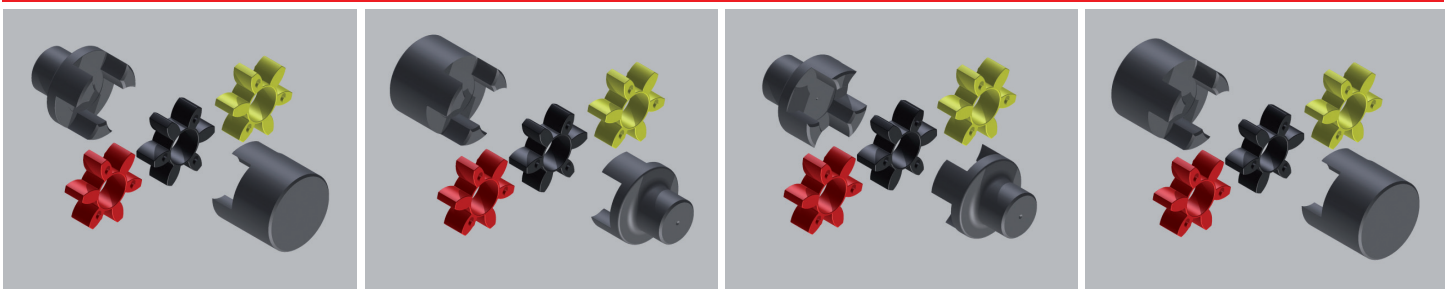

On request: we execute machining for finish bore and keyway.

IMPORTANT

The couplings can be ordered complete, or for single components: HUB 1 + Spider + HUB 2

CAD drawings available on our site www.chiaravalli.com

Quantity, availability and prices on B2B Chiaravalli





CAST-IRON GG25

STEEL*

INTERPRETATION CODES

EXAMPLE

- GE-T 19A-24B** = HUB A + HUB B
- GE-T 19A-24B** = HUB B + HUB A
- GE-T 19A-19A** = 2 HUB A
- GE-T 24B-24B** = 2 HUB B

The characteristic size of the coupling is defined by the maximum diameter bore.

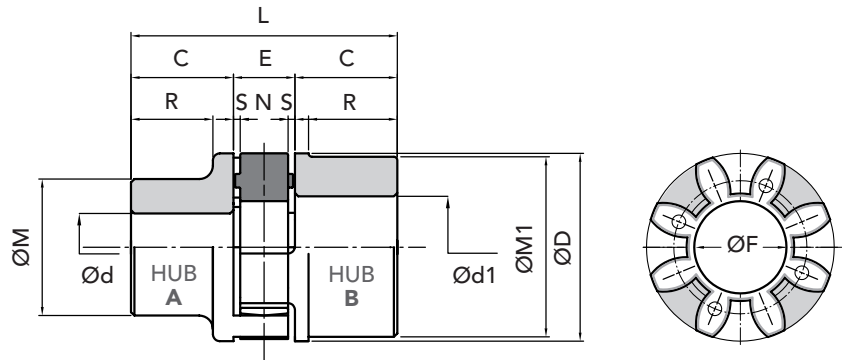

PART NUMBERS FOR COMPLETE COUPLINGS

COUPLING TYPE	HUB	COLOR SPIDER	MATERIAL	PART NUMBERS FOR COMPLETE COUPLINGS
GE-T 19-24	A + B	BLACK	STEEL	02201900
GE-T 19-24	A + B	RED	STEEL	02201901
GE-T 19-24	A + A	BLACK	STEEL	02201902
GE-T 19-24	A + A	RED	STEEL	02201903
GE-T 19-24	B + B	BLACK	STEEL	02201904
GE-T 19-24	B + B	RED	STEEL	02201905
GE-T 19-24	A + B	YELLOW	STEEL	02201906
GE-T 19-24	A + A	YELLOW	STEEL	02201907
GE-T 19-24	B + B	YELLOW	STEEL	02201908
GE-T 24-32	A + B	BLACK	CAST-IRON	02202400
GE-T 24-32	A + B	RED	CAST-IRON	02202401
GE-T 24-32	A + A	BLACK	CAST-IRON	02202402
GE-T 24-32	A + A	RED	CAST-IRON	02202403
GE-T 24-32	B + B	BLACK	CAST-IRON	02202404
GE-T 24-32	B + B	RED	CAST-IRON	02202405
GE-T 24-32	A + B	YELLOW	CAST-IRON	02202406
GE-T 24-32	A + A	YELLOW	CAST-IRON	02202407
GE-T 24-32	B + B	YELLOW	CAST-IRON	02202408
GE-T 28-38	A + B	BLACK	CAST-IRON	02202800
GE-T 28-38	A + B	RED	CAST-IRON	02202801
GE-T 28-38	A + A	BLACK	CAST-IRON	02202802
GE-T 28-38	A + A	RED	CAST-IRON	02202803
GE-T 28-38	B + B	BLACK	CAST-IRON	02202804
GE-T 28-38	B + B	RED	CAST-IRON	02202805
GE-T 28-38	A + B	YELLOW	CAST-IRON	02202806
GE-T 28-38	A + A	YELLOW	CAST-IRON	02202807
GE-T 28-38	B + B	YELLOW	CAST-IRON	02202808
GE-T 38-45	A + B	BLACK	CAST-IRON	02203800
GE-T 38-45	A + B	RED	CAST-IRON	02203801
GE-T 38-45	A + A	BLACK	CAST-IRON	02203802
GE-T 38-45	A + A	RED	CAST-IRON	02203803
GE-T 38-45	B + B	BLACK	CAST-IRON	02203804
GE-T 38-45	B + B	RED	CAST-IRON	02203805
GE-T 38-45	A + B	YELLOW	CAST-IRON	02203806
GE-T 38-45	A + A	YELLOW	CAST-IRON	02203807
GE-T 38-45	B + B	YELLOW	CAST-IRON	02203808
GE-T 42-55	A + B	BLACK	CAST-IRON	02204200
GE-T 42-55	A + B	RED	CAST-IRON	02204201
GE-T 42-55	A + A	BLACK	CAST-IRON	02204202
GE-T 42-55	A + A	RED	CAST-IRON	02204203
GE-T 42-55	B + B	BLACK	CAST-IRON	02204204
GE-T 42-55	B + B	RED	CAST-IRON	02204205
GE-T 42-55	A + B	YELLOW	CAST-IRON	02204206
GE-T 42-55	A + A	YELLOW	CAST-IRON	02204207
GE-T 42-55	B + B	YELLOW	CAST-IRON	02204208

"GIFLEX®" SERIE GE-T PART NUMBERS FOR COMPLETE COUPLINGS

CAST-IRON GG25
INTERPRETATION CODES
EXAMPLE
GE-T 19A-24B = HUB A + HUB B
GE-T 19A-24B = HUB B + HUB A
GE-T 19A-19A = 2 HUB A
GE-T 24B-24B = 2 HUB B

The characteristic size of the coupling is defined by the maximum diameter bore.

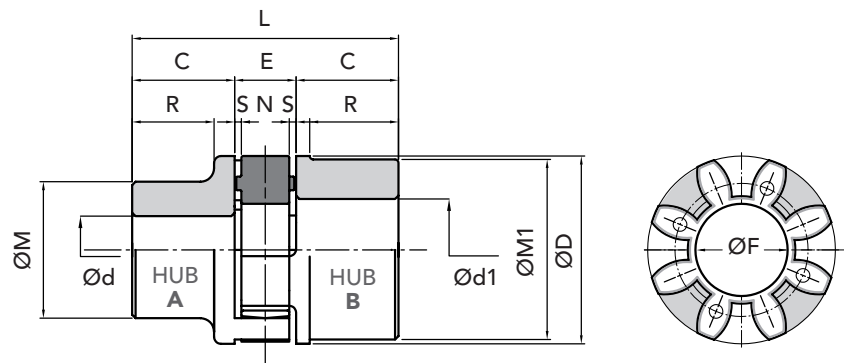
PART NUMBERS FOR COMPLETE COUPLINGS

COUPLING TYPE	HUB	COLOR SPIDER	MATERIAL	PART NUMBERS FOR COMPLETE COUPLINGS
GE-T 48-60	A + B	BLACK	CAST-IRON	02204800
GE-T 48-60	A + B	RED	CAST-IRON	02204801
GE-T 48-60	A + A	BLACK	CAST-IRON	02204802
GE-T 48-60	A + A	RED	CAST-IRON	02204803
GE-T 48-60	B + B	BLACK	CAST-IRON	02204804
GE-T 48-60	B + B	RED	CAST-IRON	02204805
GE-T 48-60	A + B	YELLOW	CAST-IRON	02204806
GE-T 48-60	A + A	YELLOW	CAST-IRON	02204807
GE-T 48-60	B + B	YELLOW	CAST-IRON	02204808
GE-T 55-70	A + B	BLACK	CAST-IRON	02205500
GE-T 55-70	A + B	RED	CAST-IRON	02205501
GE-T 55-70	A + A	BLACK	CAST-IRON	02205502
GE-T 55-70	A + A	RED	CAST-IRON	02205503
GE-T 55-70	B + B	BLACK	CAST-IRON	02205504
GE-T 55-70	B + B	RED	CAST-IRON	02205505
GE-T 55-70	A + B	YELLOW	CAST-IRON	02205506
GE-T 55-70	A + A	YELLOW	CAST-IRON	02205507
GE-T 55-70	B + B	YELLOW	CAST-IRON	02205508
GE-T 65-75	A + B	BLACK	CAST-IRON	02206500
GE-T 65-75	A + B	RED	CAST-IRON	02206501
GE-T 65-75	A + A	BLACK	CAST-IRON	02206502
GE-T 65-75	A + A	RED	CAST-IRON	02206503
GE-T 65-75	B + B	BLACK	CAST-IRON	02206504
GE-T 65-75	B + B	RED	CAST-IRON	02206505
GE-T 65-75	A + B	YELLOW	CAST-IRON	02206506
GE-T 65-75	A + A	YELLOW	CAST-IRON	02206507
GE-T 65-75	B + B	YELLOW	CAST-IRON	02206508
GE-T 75-90	A + B	BLACK	CAST-IRON	02207500
GE-T 75-90	A + B	RED	CAST-IRON	02207501
GE-T 75-90	A + A	BLACK	CAST-IRON	02207502
GE-T 75-90	A + A	RED	CAST-IRON	02207503
GE-T 75-90	B + B	BLACK	CAST-IRON	02207504
GE-T 75-90	B + B	RED	CAST-IRON	02207505
GE-T 75-90	A + B	YELLOW	CAST-IRON	02207506
GE-T 75-90	A + A	YELLOW	CAST-IRON	02207507
GE-T 75-90	B + B	YELLOW	CAST-IRON	02207508
GE-T 90-100	A + B	BLACK	CAST-IRON	02209000
GE-T 90-100	A + B	RED	CAST-IRON	02209001
GE-T 90-100	A + A	BLACK	CAST-IRON	02209002
GE-T 90-100	A + A	RED	CAST-IRON	02209003
GE-T 90-100	B + B	BLACK	CAST-IRON	02209004
GE-T 90-100	B + B	RED	CAST-IRON	02209005
GE-T 90-100	A + B	YELLOW	CAST-IRON	02209006
GE-T 90-100	A + A	YELLOW	CAST-IRON	02209007
GE-T 90-100	B + B	YELLOW	CAST-IRON	02209008



ALUMINIUM ALLOY

INTERPRETATION CODES

EXAMPLE

- GE-T 19A-24B/AI** = HUB A + HUB B
- GE-T 19A-24B/AI** = HUB B + HUB A
- GE-T 19A-19A/AI** = 2 hubs A
- GE-T 24B-24B/AI** = 2 hubs B

The characteristic size of the coupling is defined by the maximum diameter bore.

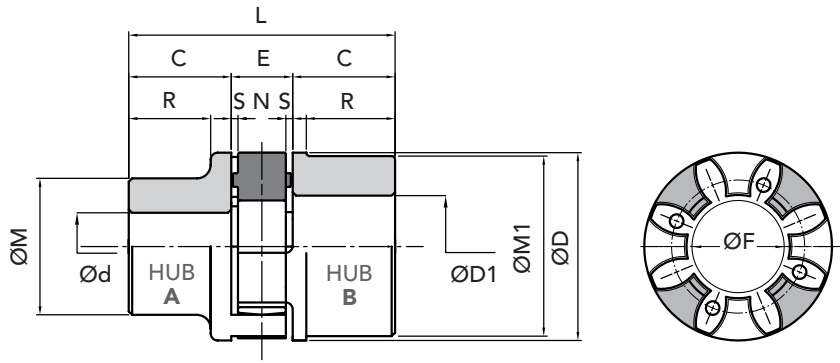

PART NUMBERS

COUPLING TYPE	PART NUMBER HUB		Spider BLACK	Spider RED	Polyurethane YELLOW spider
	A	B	92/94 shore A	96/98 shore A	92/94 shore A
GE-T 19A-24B/AI	02301920	02301940	02001910	02001911	02001912
GE-T 24A-32B/AI	02302420	02302440	02002410	02002411	02002412
GE-T 28A-38B/AI	02302820	02302840	02002810	02002811	02002812
GE-T 38A-45B/AI	02303820	02303840	02003810	02003811	02003812

MEASUREMENTS - WEIGHTS

COUPLING TYPE	Ø pilot bore		Ø finished bore		measurement in mm normal range										Weight Kg			J
	A	B	Ød max	ØD1 max	C	ØD	E	ØF	ØM	ØM1	N	R	S	L	spider	HUB A	HUB B	hubs A+B
	GE-T 19A-24B/AI	6	10	19	24	25	40	16	18	30	40	12	19	2	66	0,005	0,07	0,08
GE-T 24A-32B/AI	8	14	24	32	30	55	18	27	40	55	14	24	2	78	0,014	0,13	0,18	1
GE-T 28A-38B/AI	10	16	28	38	35	65	20	30	48	65	15	27,5	2,5	90	0,025	0,22	0,3	3
GE-T 38A-45B/AI	12	20	38	45	45	80	24	38	66	78	18	36,5	3	114	0,042	0,48	0,55	8

J inertia torque HUB A+B with bore max Ø

HUB A - B

HUB B - A

HUB A - A

HUB B - B

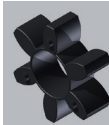
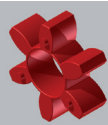
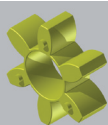
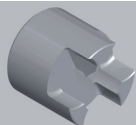
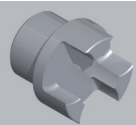
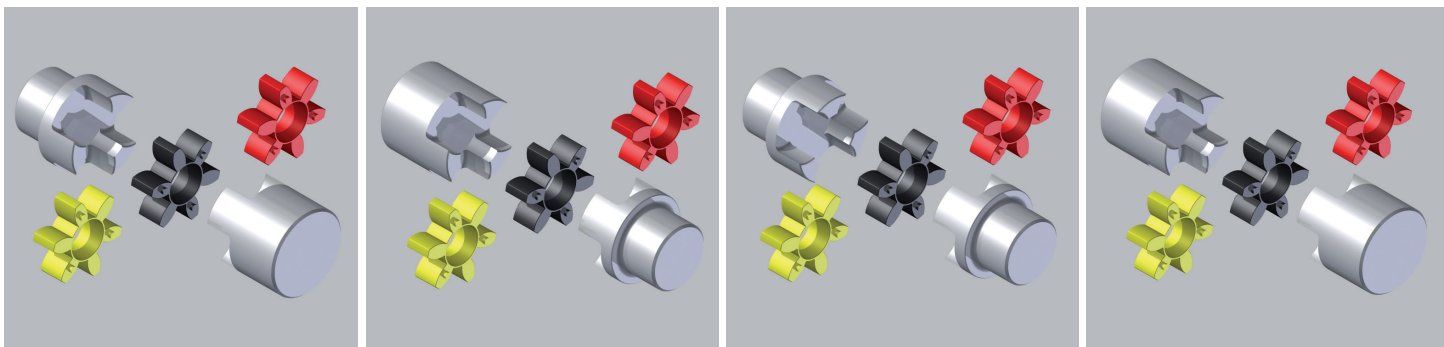

On request: we execute machining for finish bore and keyway.

IMPORTANT

The couplings can be ordered complete, or for single components: HUB 1 + Spider + HUB 2

CAD drawings available on our site www.chiaravalli.com

Quantity, availability and prices on B2B Chiaravalli



"GIFLEX®" SERIE GE-T with ELASTIC SPIDER ACCURATE EXECUTION

ALUMINIUM ALLOY
INTERPRETATION CODES
EXAMPLE
GE-T 19A-24B/AI = HUB A + HUB B
GE-T 19A-24B/AI = HUB B + HUB A
GE-T 19A-19A/AI = 2 hubs A
GE-T 24B-24B/AI = 2 hubs B

The characteristic size of the coupling is defined by the maximum diameter bore.

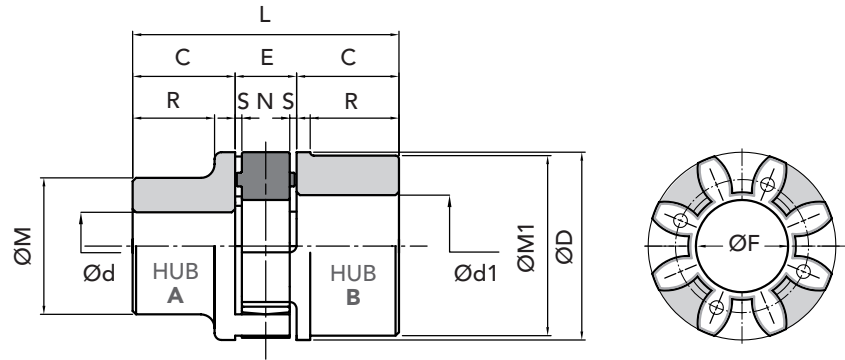
PART NUMBERS FOR COMPLETE COUPLINGS

COUPLING TYPE	HUB	COLOR SPIDER	MATERIAL	PART NUMBERS FOR COMPLETE COUPLINGS
GE-T 19-24	A + B	BLACK	ALUMINIUM	02301900
GE-T 19-24	A + B	RED	ALUMINIUM	02301901
GE-T 19-24	A + A	BLACK	ALUMINIUM	02301902
GE-T 19-24	A + A	RED	ALUMINIUM	02301903
GE-T 19-24	B + B	BLACK	ALUMINIUM	02301904
GE-T 19-24	B + B	RED	ALUMINIUM	02301905
GE-T 19-24	A + B	YELLOW	ALUMINIUM	02301906
GE-T 19-24	A + A	YELLOW	ALUMINIUM	02301907
GE-T 19-24	B + B	YELLOW	ALUMINIUM	02301908
GE-T 24-32	A + B	BLACK	ALUMINIUM	02302400
GE-T 24-32	A + B	RED	ALUMINIUM	02302401
GE-T 24-32	A + A	BLACK	ALUMINIUM	02302402
GE-T 24-32	A + A	RED	ALUMINIUM	02302403
GE-T 24-32	B + B	BLACK	ALUMINIUM	02302404
GE-T 24-32	B + B	RED	ALUMINIUM	02302405
GE-T 24-32	A + B	YELLOW	ALUMINIUM	02302406
GE-T 24-32	A + A	YELLOW	ALUMINIUM	02302407
GE-T 24-32	B + B	YELLOW	ALUMINIUM	02302408
GE-T 28-38	A + B	BLACK	ALUMINIUM	02302800
GE-T 28-38	A + B	RED	ALUMINIUM	02302801
GE-T 28-38	A + A	BLACK	ALUMINIUM	02302802
GE-T 28-38	A + A	RED	ALUMINIUM	02302803
GE-T 28-38	B + B	BLACK	ALUMINIUM	02302804
GE-T 28-38	B + B	RED	ALUMINIUM	02302805
GE-T 28-38	A + B	YELLOW	ALUMINIUM	02302806
GE-T 28-38	A + A	YELLOW	ALUMINIUM	02302807
GE-T 28-38	B + B	YELLOW	ALUMINIUM	02302808
GE-T 38-45	A + B	BLACK	ALUMINIUM	02303800
GE-T 38-45	A + B	RED	ALUMINIUM	02303801
GE-T 38-45	A + A	BLACK	ALUMINIUM	02303802
GE-T 38-45	A + A	RED	ALUMINIUM	02303803
GE-T 38-45	B + B	BLACK	ALUMINIUM	02303804
GE-T 38-45	B + B	RED	ALUMINIUM	02303805
GE-T 38-45	A + B	YELLOW	ALUMINIUM	02303806
GE-T 38-45	A + A	YELLOW	ALUMINIUM	02303807
GE-T 38-45	B + B	YELLOW	ALUMINIUM	02303808



CAST-IRON GG25

with **TAPER BUSH® LOCK**

INTERPRETATION CODES

EXAMPLE

- GE-T 28I-38E** = HUB I + HUB E
- GE-T 28E-38I** = HUB E + HUB I
- GE-T 28I-28I** = 2 hubs I
- GE-T 38E-38E** = 2 hubs E

Insertion bush:
 HUB **I** with internal assembled bush
 HUB **E** with external assembled bush

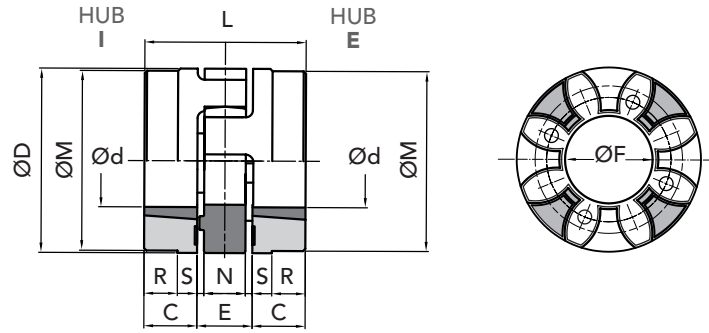

PART NUMBERS FOR COMPLETE COUPLINGS

COUPLING TYPE	PART NUMBER HUB I	PART NUMBER HUB E	Spider	Spider	Polyurethane
			BLACK 92/94 shore A	RED 96/98 shore A	YELLOW spider 92/94 shore A
GE-T 28-38 TL	03202841	03202840	02002810	02002811	02002812
GE-T 38-45 TL	03203841	03203840	02003810	02003811	02003812
GE-T 42-55 TL	03204241	03204240	02004210	02004211	02004212
GE-T 48-60 TL	03204841	03204840	02004810	02004811	02004812
GE-T 55-70 TL	03205541	03205540	02005510	02005511	02005512
GE-T 75-90 TL	03207541	03207540	02007510	02007511	02007512

MEASUREMENTS - WEIGHTS

COUPLING TYPE	Ø pilot bore	finished bore		measurement in mm normal range								Weight Kg		J Kg cm ² hubs	
		Ød max	ØD1 max	C	ØD	E	ØF	ØM	N	S	L	R	spider		HUB bore max
GE-T 28-38 TL	1108	14	25	23	65	20	30	65	15	2,5	66	-	0,025	0,50	7
GE-T 38-45 TL	1108	14	25	23	80	24	38	78	18	3	70	15	0,042	0,88	26
GE-T 42-55 TL	1610	14	42	26	95	26	46	94	20	3	78	16	0,066	1,40	36
GE-T 48-60 TL	1615	19	40	39	105	28	51	104	21	3,5	106	28	0,088	2,33	78
GE-T 55-70 TL	2012	19	50	33	120	30	60	118	22	4	96	20	0,116	2,42	120
GE-T 75-90 TL	2517	19	65	57	160	40	80	158	30	5	154	41	0,325	6,80	630

HUB I - E

HUB E - I

HUB I - I

HUB E - E

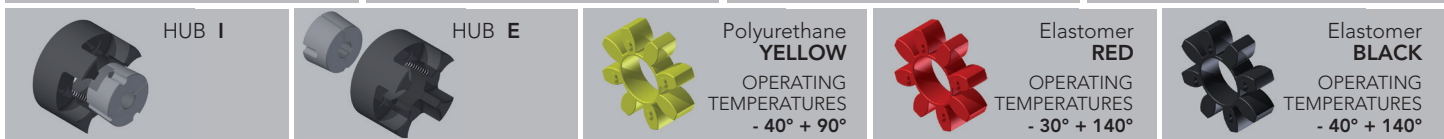
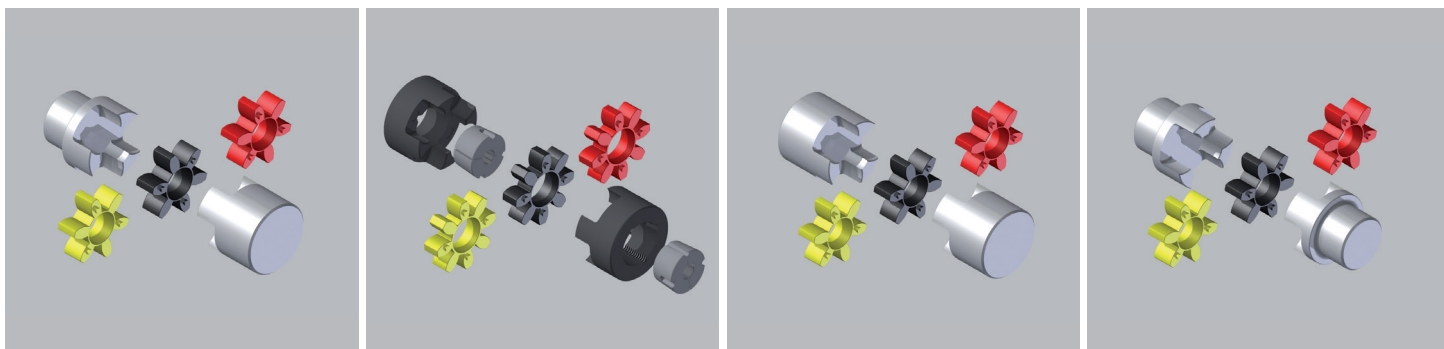

IMPORTANT

The couplings can be ordered complete, or for single components: HUB 1 + Spider + HUB 2

CAD drawings available on our site
www.chiaravalli.com

Quantity, availability and prices on B2B Chiaravalli





CAST-IRON GG25

with **TAPER BUSH® LOCK**

INTERPRETATION CODES

EXAMPLE

GE-T 28I-38E = HUB I + HUB E

GE-T 28E-38I = HUB E + HUB I

GE-T 28I-28I = 2 hubs I

GE-T 38E-38E = 2 hubs E

Insertion bush:

HUB **I** with internal assembled bush

HUB **E** with external assembled bush

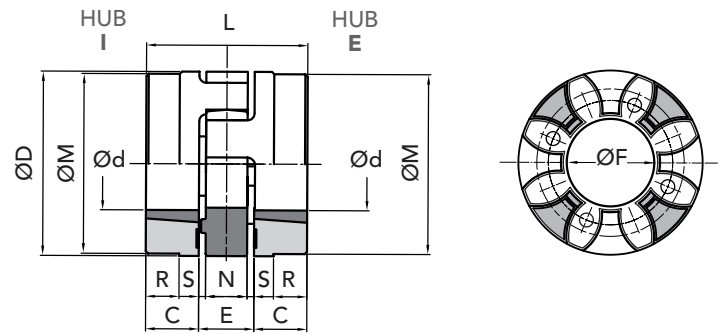

PART NUMBERS FOR COMPLETE COUPLINGS

COUPLING TYPE	HUB	COLOR SPIDER	MATERIAL	PART NUMBERS FOR COMPLETE COUPLINGS
GE-T 28-38	E + I	BLACK	CAST-IRON	03202800
GE-T 28-38	E + I	RED	CAST-IRON	03202801
GE-T 28-38	E + E	RED	CAST-IRON	03202802
GE-T 28-38	I + I	RED	CAST-IRON	03202803
GE-T 28-38	E + E	BLACK	CAST-IRON	03202804
GE-T 28-38	I + I	BLACK	CAST-IRON	03202805
GE-T 28-38	E + I	YELLOW	CAST-IRON	03202806
GE-T 28-38	E + E	YELLOW	CAST-IRON	03202807
GE-T 28-38	I + I	YELLOW	CAST-IRON	03202808
GE-T 38-45	E + I	BLACK	CAST-IRON	03203800
GE-T 38-45	E + I	RED	CAST-IRON	03203801
GE-T 38-45	E + E	RED	CAST-IRON	03203802
GE-T 38-45	I + I	RED	CAST-IRON	03203803
GE-T 38-45	E + E	BLACK	CAST-IRON	03203804
GE-T 38-45	I + I	BLACK	CAST-IRON	03203805
GE-T 38-45	E + I	YELLOW	CAST-IRON	03203806
GE-T 38-45	E + E	YELLOW	CAST-IRON	03203807
GE-T 38-45	I + I	YELLOW	CAST-IRON	03203808
GE-T 42-55	E + I	BLACK	CAST-IRON	03204200
GE-T 42-55	E + I	RED	CAST-IRON	03204201
GE-T 42-55	E + E	RED	CAST-IRON	03204202
GE-T 42-55	I + I	RED	CAST-IRON	03204203
GE-T 42-55	E + E	BLACK	CAST-IRON	03204204
GE-T 42-55	I + I	BLACK	CAST-IRON	03204205
GE-T 42-55	E + I	YELLOW	CAST-IRON	03204206
GE-T 42-55	E + E	YELLOW	CAST-IRON	03204207
GE-T 42-55	I + I	YELLOW	CAST-IRON	03204208
GE-T 48-60	E + I	BLACK	CAST-IRON	03204800
GE-T 48-60	E + I	RED	CAST-IRON	03204801
GE-T 48-60	E + E	RED	CAST-IRON	03204802
GE-T 48-60	I + I	RED	CAST-IRON	03204803
GE-T 48-60	E + E	BLACK	CAST-IRON	03204804
GE-T 48-60	I + I	BLACK	CAST-IRON	03204805
GE-T 48-60	E + I	YELLOW	CAST-IRON	03204806
GE-T 48-60	E + E	YELLOW	CAST-IRON	03204807
GE-T 48-60	I + I	YELLOW	CAST-IRON	03204808
GE-T 55-70	E + I	BLACK	CAST-IRON	03205500
GE-T 55-70	E + I	RED	CAST-IRON	03205501
GE-T 55-70	E + E	RED	CAST-IRON	03205502
GE-T 55-70	I + I	RED	CAST-IRON	03205503
GE-T 55-70	E + E	BLACK	CAST-IRON	03205504
GE-T 55-70	I + I	BLACK	CAST-IRON	03205505
GE-T 55-70	E + I	YELLOW	CAST-IRON	03205506
GE-T 55-70	E + E	YELLOW	CAST-IRON	03205507
GE-T 55-70	I + I	YELLOW	CAST-IRON	03205508
GE-T 75-90	E + I	BLACK	CAST-IRON	03207500
GE-T 75-90	E + I	RED	CAST-IRON	03207501
GE-T 75-90	E + E	RED	CAST-IRON	03207502
GE-T 75-90	I + I	RED	CAST-IRON	03207503
GE-T 75-90	E + E	BLACK	CAST-IRON	03207504
GE-T 75-90	I + I	BLACK	CAST-IRON	03207505
GE-T 75-90	E + I	YELLOW	CAST-IRON	03207506
GE-T 75-90	E + E	YELLOW	CAST-IRON	03207507
GE-T 75-90	I + I	YELLOW	CAST-IRON	03207508



EXAMPLES OF APPLICATION

With three-phase motors 50Hz
 maximum r.p.m. 3000

Technical data under reported as the
 typology of the coupling do not engage
 the CHIARAVALLI GROUP SpA and are
 shown only for application example.



MOTOR ELECTRIC TYPE	Ø d MOTOR SHAFT	Motor Power output at 50 Hz n = 3000 min		COUPLING	
		P (kW)	T (Nm)	TYPE GE-T	Fs
80	19	1,1	3,6	19/24	5,4
90 S	24	1,5	4,9		4,0
90 L	24	2,2	7,2		2,7
100 L	28	3	9,8	24/32	7,1
112 M	28	4	13,1		5,4
132 S	38	7,5	-	28/38	7,6
132 M	38	-	-		-
160 M	42	15	49	38/45	7,8
160 L	42	18,5	60		6,3
180 M	48	22	72	42/55	7,5
180 L	48	-	-		-
200 L	55	37	121		4,4
225 S	60	-	-	48/60	-
225 M	60	45	47		3,7
250 M	65	55	180		3,5
280 S	75	75	246	55/70	3,1
280 M	75	90	295		2,6
315 S	80	110	360		2,1
315 M	80	132	433	75/90	4,6
315 L	80	200	656		3,0
355 L	100	315	1010	90/100	4,8
400 L	100	400	1280		3,8

SERIES GE-T COUPLING EXAMPLE OF APPLICATION for STANDARD MOTOR CE



INTRODUCTION

The aluminium flexible couplings GE-T SG are made of three pre-tensioned elements in backlash-free execution. They are meant for the coupling mounting and they are designed to fit low torque working units and industrial processing, where they must satisfy certain requirements.

Thanks to their limited dimensions and their easy mounting, they can operate in little space and any project can take big advantages of it.

FEATURES

The buckle tightening guarantees a quick and sure fixing without extension between shaft and hub. It is however important to keep the screw tightening torque (MS) shown in the table.

Besides testing the size of the coupling given in the table, it is suggested to test the maximum torque of buckle to diameter (F).

The elastomeric element, that has a star shape, is set into the hubs' hollow seats with a light pre-tensioning, ensuring the needed transmission torque backlash-free execution.

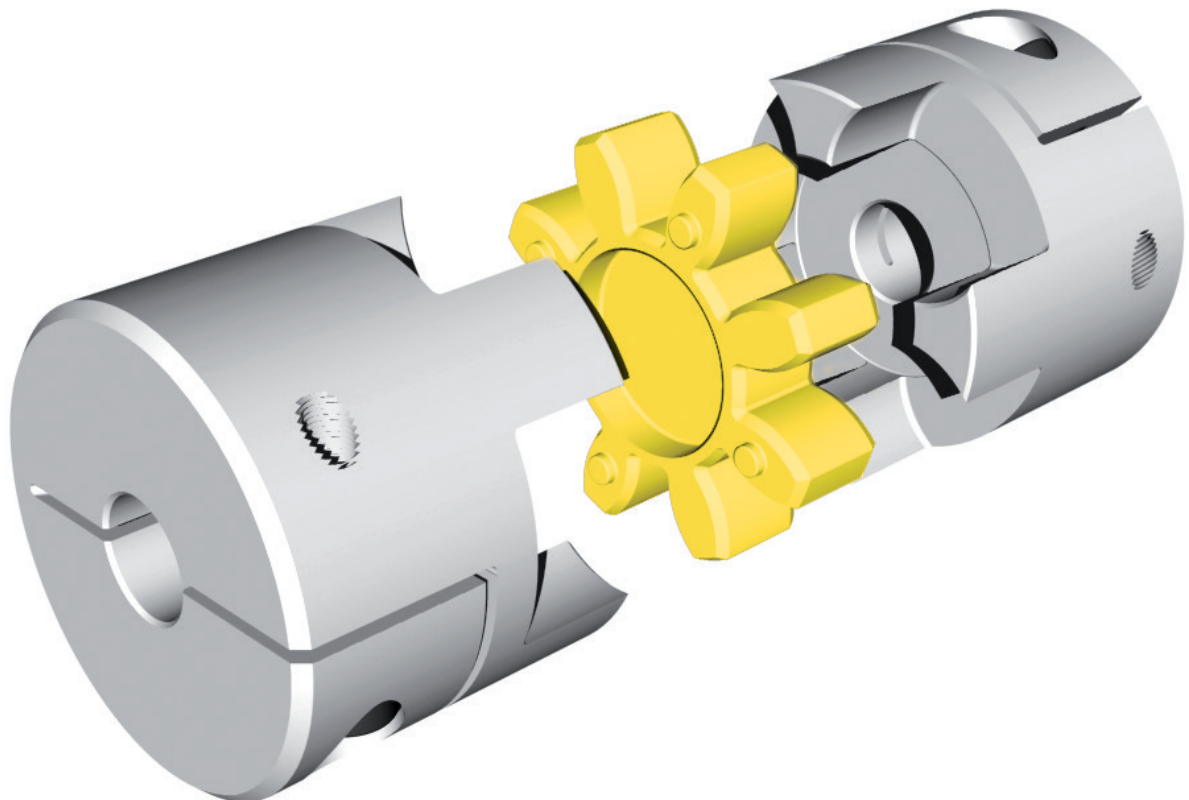
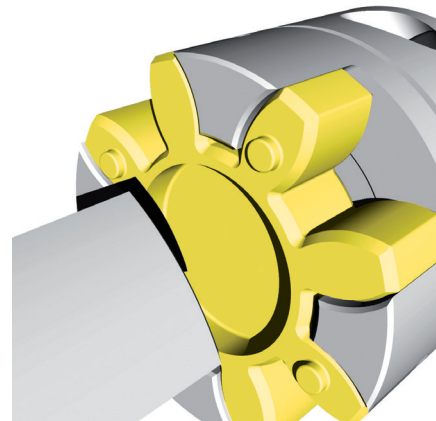
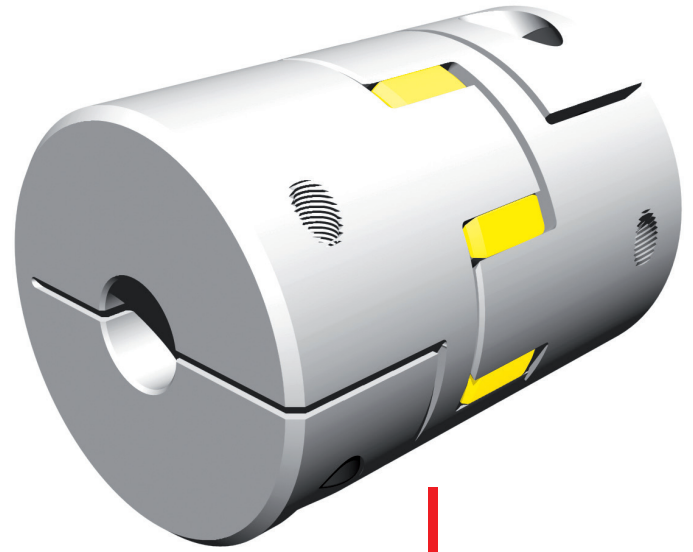

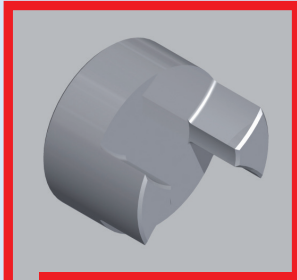

HUB EXECUTION A

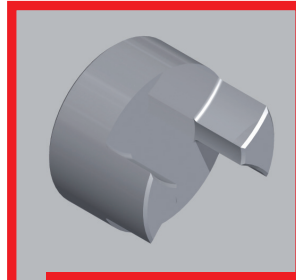

HUB EXECUTION B

The difference between Hub Execution A and Hub Execution B is given by the hub dimensions.

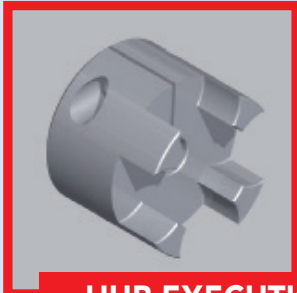

HUB EXECUTION C

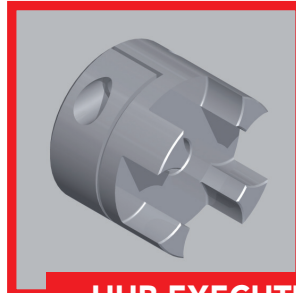

HUB EXECUTION D

The difference between Hub Execution C and Hub Execution D is given by the side cuts.

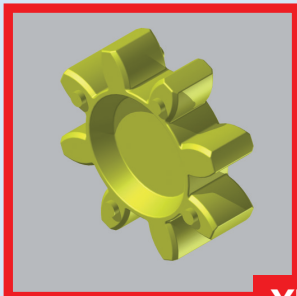

YELLOW POLYURETHANE SPIDER

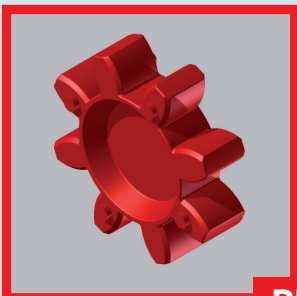

RED ELASTOMER SPIDER

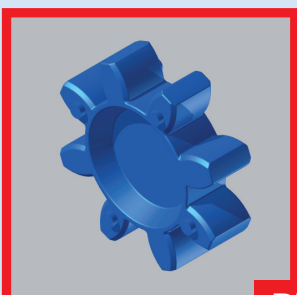

BLU ELASTOMER SPIDER

BACKLASH-FREE COUPLING
HUB EXECUTION A
SOLID IN ALUMINIUM

with spider

 4 pointed **GE-T 09 SG**
GE-T 14 SG

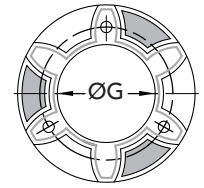
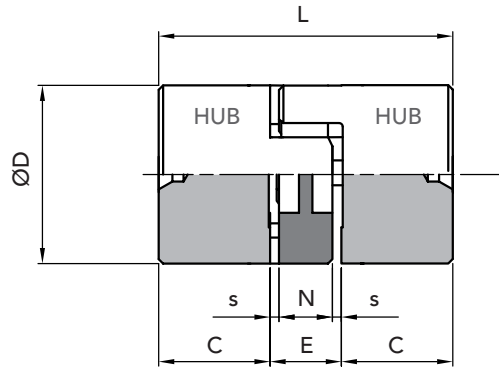
 6 pointed **GE-T 19-24 SG**

with spider 6 pointed

TECHNICAL DATA

COUPLING TYPE	HARDNESS		r.p.m. max	Nm		Stiffness			Weight kg.		Max inertia moment
	WITH SPIDER			Tk n couple	Tk max couple	Tors. static	Tors. dynam.	radial			
GE-T 09 SG	80	4 punte	28000	1,8	3,6	17,02	52	125	0,009	0,002	0,57
	92/94	4 punte		3,0	6,0	31,5	95	262			
	96/98	4 punte		5,0	10,0	51,5	150	518			
GE-T 14 SG	80	4 punte	19000	4,0	8,0	60,2	180	153	0,020	0,005	3,25
	92/94	4 punte		7,5	15,0	114,6	344	336			
	96/98	4 punte		12,5	25,0	172,0	513	604			
GE-T 19-24 SG	80	6 punte	14000	4,9	9,8	343,8	1030	582	0,066	0,007	21,90
	92/94	6 punte		10,0	20,0	573,0	1720	1120			
	96/98	6 punte		17,0	34,0	859,0	2580	2010			

NB: with radial speed more than $v=30\text{m/s}$ dynamic balancing is needed.

COUPLING TYPE	PART NUMBER HUB SOLID	Polyurethane BLU	Polyurethane RED	Polyurethane YELLOW
		80 shore A	96/98 shore A	92/94 shore A
GE-T 09 SG	02509200	02509102	02509104	02509100
GE-T 14 SG	02514200	02514102	02514104	02514100
GE-T 19-24 SG	02519200	02519102	02519104	02519100

DIMENSIONS

COUPLING TYPE	achievable Ø minimum bore	achievable Ø maximum bore	Ø D	Ø G	L	C	E	N	S
GE-T 14 SG	4	14	30	10,5	35	11	13	10	1,5
GE-T 19-24 SG	10	20	40	18	66	25	16	12	2,0

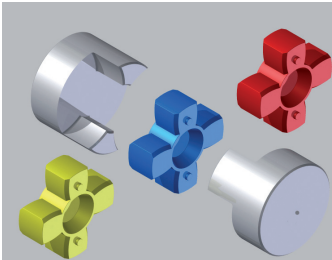
GE-T COUPLING SG WITH HUB EXECUTION A SOLID IN ALUMINIUM

HUB

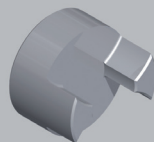
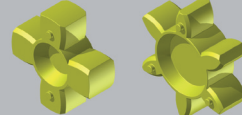
 Polyurethane **YELLOW**

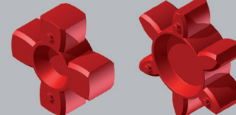
 OPERATING TEMPERATURES
 - 40° + 90°

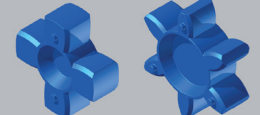
 Polyurethane **RED**

 OPERATING TEMPERATURES
 - 30° + 90°

 Polyurethane **BLU**

 OPERATING TEMPERATURES
 - 50° + 80°

On request: we execute machining for finish bore and keyway.

IMPORTANT

 The coupling can be ordered for single components
 HUB 1 + Elastomer Spider + HUB 2

 CAD drawings available on our site
www.chiaravalli.com

HUBS EXECUTION A

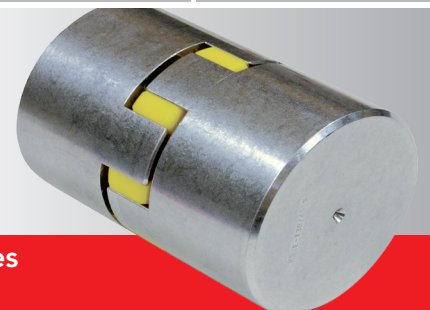
**Quantity, availability and prices
 on B2B Chiaravalli**



BACKLASH-FREE COUPLING

HUB EXECUTION B

SOLID IN ALUMINIUM

with spider

6 pointed **GE-T 24-28 SG**

8 pointed **GE-T 28-38 SG**

GE-T 38/45 SG

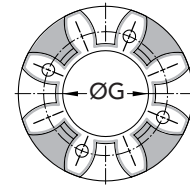
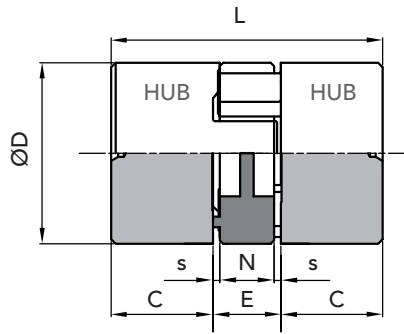

with spider 8 pointed

TECHNICAL DATA

COUPLING TYPE	HARDNESS	r.p.m.	Nm		Stiffness			Weight kg.		Max inertial moment	
			WITH SPIDER	max	Tk n	Tk max	Tors. statica	Tors. dinam.	radial		
GE-T 24-28 SG	80 6 punte	10600		17,0	34,0	1432,0	4296	1480	0,132	0,018	58,30
	92/94 6 punte			35,0	70,0						
	96/98 6 punte			60,0	120,0						
GE-T 28-38 SG	80 8 punte	8500		46,0	92,0	2292,0	6879	1780	0,253	0,029	216,80
	92/94 8 punte			95,0	190,0						
	96/98 8 punte			160,0	320,0						
GE-T 38-45 SG	80 8 punte	7100		94,0	188,0	4589,0	13752	2350	0,455	0,049	445,20
	92/94 8 punte			190,0	380,0						
	96/98 8 punte			325,0	650,0						

NB: with radial speed more than v=30m/s dynamic balancing is needed.

COUPLING TYPE	PART NUMBER	HUB SOLID	Polyurethane BLU	Polyurethane RED	Polyurethane YELLOW
			80 shore A	96/98 shore A	92/94 shore A
GE-T 24-28 SG		02524200	02524102	02524104	02524100
GE-T 28-38 SG		02528200	02528102	02528104	02528100
GE-T 38-45 SG		02538200	02538102	02538104	02538100

DIMENSIONS

COUPLING TYPE	achievable Ø minimum bore	achievable Ø maximum bore	ØD	ØG	L	C	E	N	S
	GE-T 24-28 SG	15	28	55	27	78	30	18	14
GE-T 28-38 SG	19	35	65	30	90	35	20	15	2,5
GE-T 38-45 SG	20	45	80	38	114	45	24	18	3,0

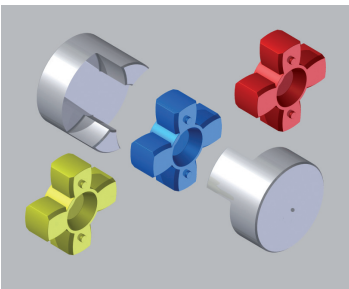

GE-T COUPLING SG WITH HUB EXECUTION B SOLID IN ALUMINIUM

HUB	Polyurethane YELLOW OPERATING TEMPERATURES - 40° + 90°	Polyurethane RED OPERATING TEMPERATURES - 30° + 90°	Polyurethane BLU OPERATING TEMPERATURES - 50° + 80°
-----	--	---	---

On request: we execute machining for finish bore and keyway.

IMPORTANT

The coupling can be ordered for single components HUB 1 + Elastomer Spider + HUB 2

CAD drawings available on our site www.chiaravalli.com

HUB EXECUTION C B

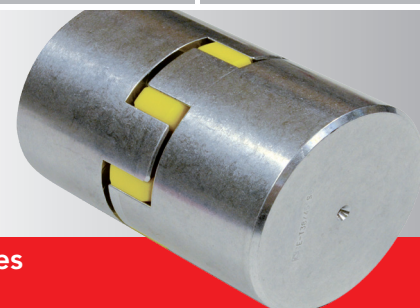

Quantity, availability and prices on B2B Chiaravalli

"GIFLEX®" SERIES GE-T BACKLASH-FREE TORSIONAL COUPLING EXECUTION HUB B



BACKLASH-FREE COUPLING
HUB EXECUTION C

WITH SIMPLE CUT
ALUMINIUM ALLOY
with spider

4 pointed **GE-T 09 SG**

GE-T 14 SG

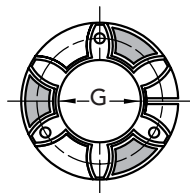
6 pointed **GE-T 19-24 SG**

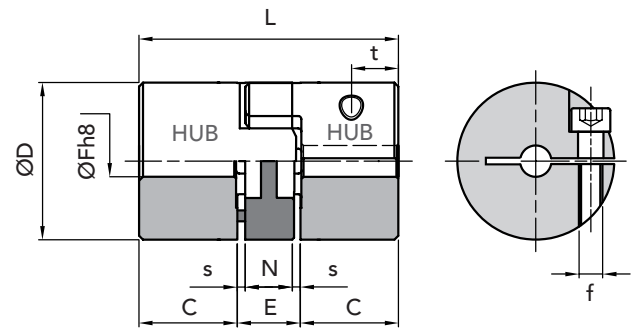

with spider
6 pointed

TECHNICAL DATA

COUPLING TYPE	HARDNESS		r.p.m. max	Nm		Stiffness			Weight kg.		Max inertial moment
	WITH SPIDER			Tk n couple	Tk max couple	Tors. statica	Tors. dinam.	radial			
GE-T 09 SG	80	4 pointed	28000	1,8	3,6	17,02	52	125	0,009	0,002	0,57
	92/94	4 pointed		3,0	6,0	31,5	95	262			
	96/98	4 pointed		5,0	10,0	51,5	150	518			
GE-T 14 SG	80	4 pointed	19000	4,0	8,0	60,2	180	153	0,020	0,005	3,25
	92/94	4 punte		7,5	15,0	114,6	344	336			
	96/98	4 punte		12,5	25,0	172,0	513	604			
GE-T 19-24 SG	80	6 punte	14000	4,9	9,8	343,8	1030	582	0,066	0,007	21,90
	92/94	6 punte		10,0	20,0	573,0	1720	1120			
	96/98	6 punte		17,0	34,0	859,0	2580	2010			

NB: with radial speed more than $v=30\text{m/s}$ dynamic balancing is needed.

COUPLING TYPE	PART NUMBER HUB EXECUTION C WITH SIMPLE CUT	Polyurethane BLU 80 shore A	Polyurethane RED 96/98 shore A	Polyurethane YELLOW 92/94 shore A
GE-T 09 SG	025092-- + Ø bore	02509102	02509104	02509100
GE-T 14 SG	025142-- + Ø bore	02514102	02514104	02514100
GE-T 19-24 SG	025192-- + Ø bore	02519102	02519104	02519100

DIMENSIONS

COUPLING TYPE	Version	ØF available holes with H8 tolerance	ØD ØG L C E N s f										Ms screws (Nm) clamping torque t	
			ØD	ØG	L	C	E	N	s	f				
GE-T 09 SG	A	5-6-8-10	20	7,2	30	10	10	8	1,0	M2,5	0,75	5		
GE-T 14 SG	A	5-6-8-10-12-14-15-16	30	10,5	35	11	13	10	2,5	M3	1,40	5		
GE-T 19-24 SG	A	8-10-12-14-15-16-18-19-20	40	18	66	25	16	12	2,0	M6	11,0	12		

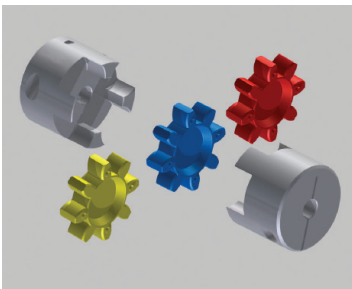
GE-T COUPLING SG WITH HUB EXECUTION C SIMPLE CUT ALUMINIUM ALLOY

HUB

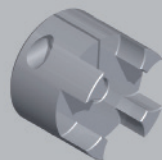

Polyurethane **YELLOW**

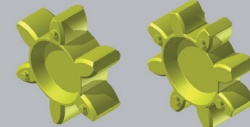

OPERATING TEMPERATURES
- 40° + 90°

Polyurethane **RED**

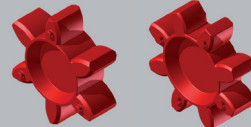

OPERATING TEMPERATURES
- 30° + 90°

Polyurethane **BLU**

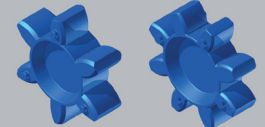

OPERATING TEMPERATURES
- 50° + 80°

IMPORTANT

The coupling can be ordered for single components
HUB 1 + Elastomer Spider + HUB 2

HUBS EXECUTION C



CAD drawings available on our site
www.chiaravalli.com

Quantity, availability and prices
on B2B Chiaravalli



BACKLASH-FREE COUPLING

HUB EXECUTION D

WITH DOUBLE CUT
 ALUMINIUM ALLOY

with spider

8 pointed

GE-T 24-28 SG

GE-T 28-38 SG

GE-T 38/45 SG

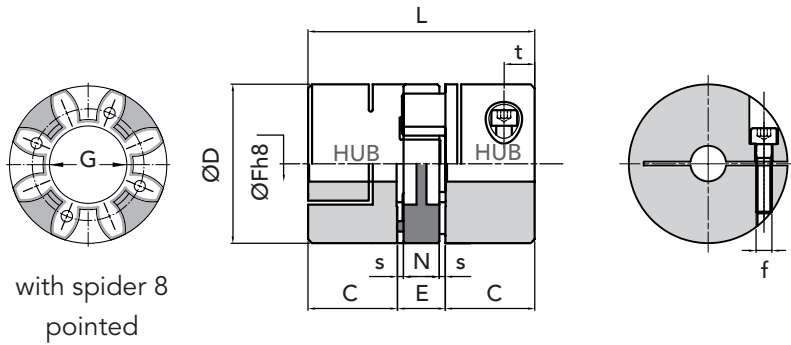

with spider 8 pointed

TECHNICAL DATA

COUPLING TYPE	HARDNESS		r.p.m.	Nm		Stiffness			Weight kg.		Max inertial moment
	WITH SPIDER			Tk n	Tk max	Tors. static	Tors. dynam.	radial			
GE-T 24-28 SG	80	8 POINTED	10600	17,0	34,0	1432,0	4296	1480	0,132	0,018	58,30
	92/94	8 punte		35,0	70,0						
	96/98	8 punte		60,0	120,0						
GE-T 28-38 SG	80	8 punte	8500	46,0	92,0	2292,0	6879	1780	0,253	0,029	216,80
	92/94	8 punte		95,0	190,0						
	96/98	8 punte		160,0	320,0						
GE-T 38-45 SG	80	8 punte	7100	94,0	188,0	4589,0	13752	2350	0,455	0,049	445,20
	92/94	8 punte		190,0	380,0						
	96/98	8 punte		325,0	650,0						

NB: with radial speed more than v=30m/s dynamic balancing is needed.

COUPLING TYPE	PART NUMBER HUB EXECUTION D WITH DOUBLE CUT	Polyurethane	Polyurethane	Polyurethane
		BLU 80 shore A	RED 96/98 shore A	YELLOW 92/94 shore A
GE-T 24-28 SG	025242-- + Ø bore	02524102	02524104	02524100
GE-T 28-38 SG	025282-- + Ø bore	02528102	02528104	02528100
GE-T 38-45 SG	025382-- + Ø bore	02538102	02538104	02538100

DIMENSIONS

COUPLING TYPE	Version	ØF available holes with H8 tollerance									Ms screw (Nm) clamping torque		t
			ØD	ØG	L	C	E	N	s	f			
GE-T 24-28 SG	B	12-14-15-16-18-19-20-22-24-25-28	55	27	78	30	18	14	2,0	M6	11,0	14	
GE-T 28-38 SG	B	18-19-20-22-24-25-28-30-32-35	65	30	90	35	20	15	2,5	M8	25,0	15	
GE-T 38-45 SG	B	18-19-20-22-24-25-28-30-32-35-38-40	80	38	114	45	24	18	3,0	M8	25,0	20	

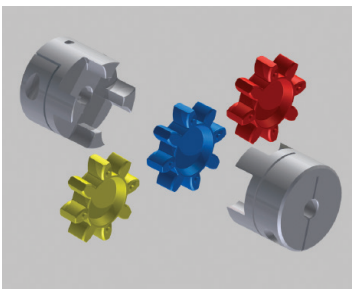

COUPLING GE-T SG WITH HUB EXECUTION D DOUBLE CUT ALUMINIUM ALLOY

HUB	Polyurethane YELLOW	Polyurethane RED	Polyurethane BLU
	OPERATING TEMPERATURES - 40° + 90°	OPERATING TEMPERATURES - 30° + 90°	OPERATING TEMPERATURES - 50° + 80°

HUBS EXECUTION D



IMPORTANT

The coupling can be ordered for single components
 HUB 1 + Elastomer Spider + HUB 2

CAD drawings available on our site
www.chiaravalli.com

Quantity, availability and prices
 on B2B Chiaravalli



GF COUPLINGS with POLYAMIDE SLEEVE

GF COUPLINGS with POLYAMIDE SLEEVE

SERIES GF



GF COUPLINGS
with POLYAMIDE SLEEVE



PRESENTATION

The GIFLEX range of flexible toothed couplings are commercial couplings for general applications, which are however manufactured to a high quality standard and offer technical and performance features that are typical of industrial couplings. The specific application sector refers to power transmissions for the flexible connection of rotating parts, with the possibility of compensating radial and angular misalignments and absorbing axial slippage.

The performance is in line with this class of couplings, rendered more demanding and better suited to the needs of industrial requirements by the design criteria adopted and the precision with which the couplings are machined and systematically tested.

CONSTRUCTION

In structural terms, the flexible toothed couplings consist of two symmetrical steel hubs and a synthetic resin sleeve, which ensures the coupling and power transmission between the two hubs.

The two hubs are manufactured from low carbon content steel and have been subjected to anti-corrosion surface treatment and are each fitted with a toothed ring.

The hollow sleeve with internal toothing formed by injection moulding comprises a high molecular weight semi-crystalline technical polymer, guaranteed by certification at origin, thermally conditioned and charged with a solid lubricant that contributes to enhance the self-lubricating features typical of the polymer. The toothing of the two hubs has a progressive dual curvature, produced using a Numerically Controlled machine tool, which ensures the coupling provides optimum performance. This solution enables dynamic type angular and radial misalignments to be compensated **ALSO UNDER LOAD CONDITIONS**. The specific geometry of the tooth for a given transmitted twisting moment significantly reduces the surface pressure, thereby increasing the coupling's capacity to transmit the load and fatigue resistance.

The polymer's relative insensitivity to atmospheric humidity and its capacity to withstand temperatures between -20° and $+120^{\circ}$ with brief peaks of up to $+150^{\circ}$ enable the coupling to withstand demanding working conditions also in an aggressive environment.

CHARACTERISTICS

The couplings provide the following performance in practical applications:

- Reduced overall dimensions, weight and inertia moment;
- Constant velocity behaviour at speed;
- Silent operation and the ability to absorb impacts and vibrations flexibly;
- Withstand the most common aggressive chemical agents and moderate heat, max. temp. 80° ;
- Self-lubricating, electrically insulated and maintenance-free;
- Inexpensive, easily assembled and are suited to a variety of applications, also in demanding conditions.

TIPOLOGY of HUBS for SERIES GF



NORMAL HUB

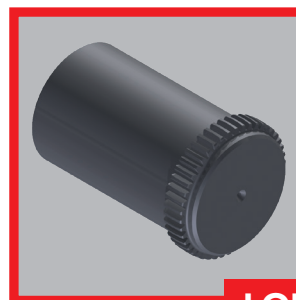

LONG HUB

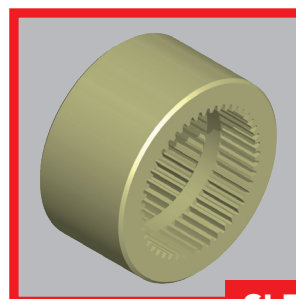

SLEEVE



COUPLING SELECTION

Torque based selection:
the coupling must be selected so that the max motor torque does not exceed the coupling's per-mitted peak twisting moment.

ASSEMBLY GUIDELINES

- Position the two semi-couplings on the shafts, taking care that the internal surfaces are in line with the shaft ends.
- Insert the sleeve on the two semi-couplings adjusting their distance (distance "G"), while the two shafts are aligned at the same time.
- Clamp the two parts to be coupled together in position.
- Check that the sleeve is free to move in an axial direction before the coupling is rotated.

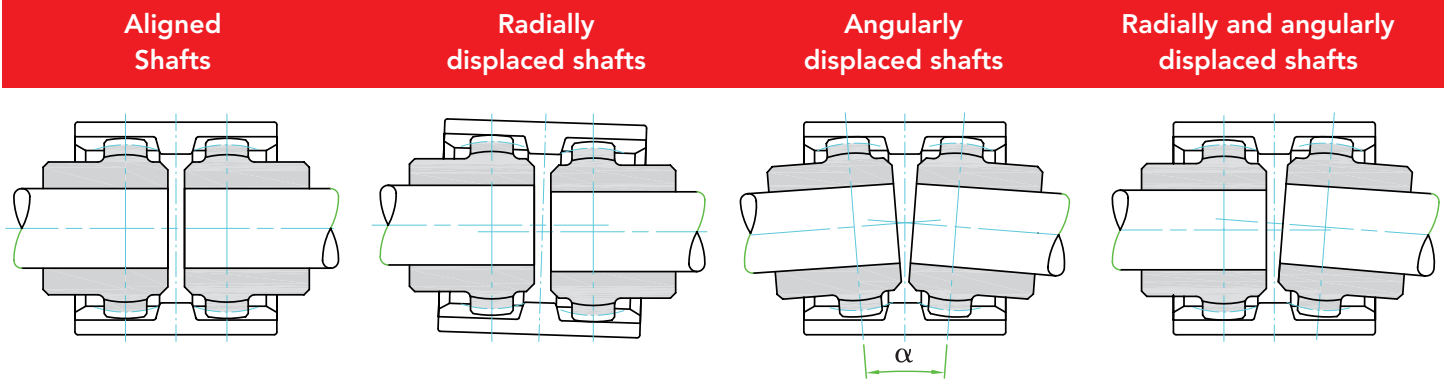

TECHNICAL DATA

COUPLING TYPE	Power factor Kw r.p.m.		Torque Nm		power transmitted in kw at r.p.m.								r.p.m. max	mass kg	J kg cm ²	Maximum misalignment for each hub		Axial displacement mm
	norm	max	norm	max	750		1000		1500		3000					Angular a	Radial mm	
					norm	max	norm	max	norm	max	norm	max						
GF 14	0,0011	0,0023	11,5	23	0,8	1,5	1,1	2,0	1,6	3,0	3,3	6,0	14.000	0,166	0,27	± 2°	0,7	± 1
GF 19	0,0019	0,0037	18,5	36,5	1,3	2,7	1,8	3,7	2,7	5,5	5,4	11,1	12.000	0,276	0,64	± 2°	0,8	± 1
GF 24	0,0023	0,0047	23	46	1,7	3,5	2,3	4,7	3,4	7,0	6,9	14,1	10.000	0,312	0,92	± 2°	0,8	± 1
GF 28	0,0053	0,0106	51,5	103,5	3,9	7,9	5,2	10,6	7,8	15,9	15,6	31,8	8.000	0,779	3,45	± 2°	1,0	± 1
GF 32	0,0071	0,0142	69	138	5,2	10,5	7,0	14,1	10,5	21,1	21,0	42,3	7.100	0,918	5,03	± 2°	1,0	± 1
GF 38	0,0090	0,0181	88	176	6,7	13,5	9,0	18,0	13,5	27,0	27,0	54,0	6.300	1,278	9,59	± 2°	0,9	± 1
GF 42	0,0113	0,0226	110	220	8,4	16,8	11,2	22,5	16,8	33,7	33,6	67,5	6.000	1,473	13,06	± 2°	0,9	± 1
GF 48	0,0158	0,0317	154	308	11,8	23,6	15,8	31,6	23,7	47,4	47,4	94,8	5.600	1,777	18,15	± 2°	0,9	± 1
GF 55	0,029	0,058	285	570	21,7	43,5	29,0	58,0	43,5	87,0	87,0	174,0	4.800	3,380	49,44	± 2°	1,2	± 1
GF 65	0,0432	0,0865	420	840	32,1	64,3	42,9	85,8	64,3	128,7	128,7	257,4	4.000	4,988	106,34	± 2°	1,3	± 1

J inertia moment HUB A+B
with bore Ø max

CAD drawings available on our site
www.chiaravalli.com

Quantity, availability and prices
on B2B Chiaravalli



POLYAMIDE SLEEVE

INTERPRETATION CODES

EXAMPLE

GF 14-NN with 2 normal hubs

GF 14-NL with 1 normal hubs
and 1 long hub

GF 14-LL with 2 long hubs

The characteristic size of the coupling is defined by the maximum diameter bore.

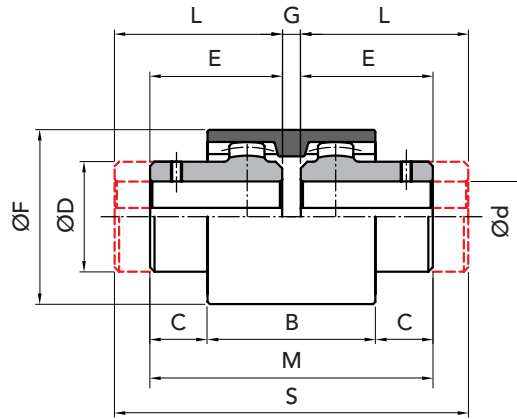

PART NUMBERS FOR COMPLETE COUPLING

PART NUMBERS FOR SIMPLE COMPONENTS

COUPLING TYPE	P. NUMBER			HUB NORMAL	HUB LONG	Sleeve NYLON
	GF NN	GF NL	GF LL			
GF 14	00101402	00101400	00101404	00101420	00101440	00101410
GF 19	00101902	00101900	00101904	00101920	00101940	00101910
GF 24	00102402	00102400	00102404	00102420	00102440	00102410
GF 28	00102802	00102800	00102804	00102820	00102840	00102810
GF 32	00103202	00103200	00103204	00103220	00103240	00103210
GF 38	00103802	00103800	00103804	00103820	00103840	00103810
GF 42	00104202	00104200	00104204	00104220	00104240	00104210
GF 48	00104802	00104800	00104804	00104820	00104840	00104810
GF 55	00105502	00105500	00105504	00105520	00105540	00105510
GF 65	00106502	00106500	00106504	00106520	00106540	00106510

MEASUREMENTS - WEIGHTS

COUPLING TYPE	without bore	Ød available holes with H7 tolerance		measurement in mm										Kg		
		ON REQUEST		for normal range hubs								long hubs series		sleeve	HUB normal	HUB long
		min	max	B	C	ØD	E	ØF	G	M	L	S				
GF 14	-	6	14	38	6,5	25	23,5	41	4	51	30	64	0,022	0,10	0,13	
GF 19	-	8	19	38	8,5	32	25,5	48	4	55	40	84	0,028	0,18	0,28	
GF 24	-	10	24	42	7,5	36	26,5	52	4	57	50	104	0,037	0,23	0,42	
GF 28	-	10	28	48	19	45	41	68	4	86	60	124	0,086	0,54	0,79	
GF 32	-	12	32	48	18	50	40	75	4	84	60	124	0,104	0,66	0,97	
GF 38	-	14	38	50	17	58	40	85	4	84	80	164	0,131	0,93	1,83	
GF 42	-	20	42	50	19	63	42	95	4	88	110	224	0,187	1,10	2,76	
GF 48	-	20	48	50	27	68	50	100	4	104	110	224	0,198	1,50	3,21	
GF 55	-	25	55	65	29,5	82	60	120	4	124	110	224	0,357	2,63	5,12	
GF 65	-	25	65	72	36	95	70	140	4	144	140	284	0,595	4,02	7,90	

GF NN

GF NL

GF LL

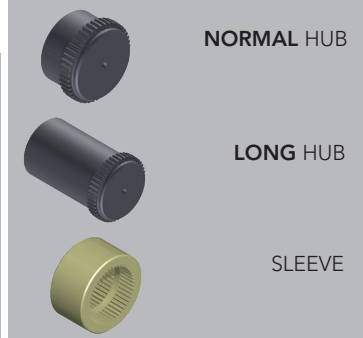
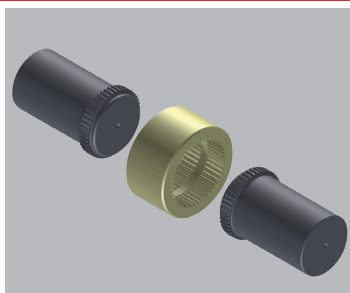
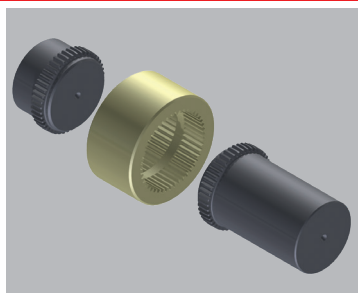
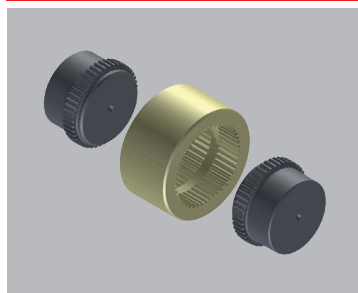

IMPORTANT

The GF couplings can be ordered complete or for single items.

CAD drawings available on our site
www.chiaravalli.com

Quantity, availability and prices
 on B2B Chiaravalli

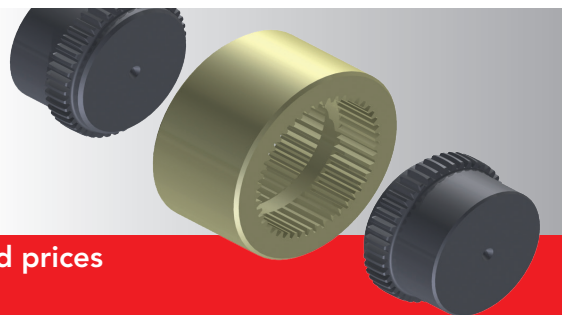



SERIES GFA



GFA COUPLING with Steel Sleeve



PRESENTATION

The "GIFLEX®" GFA range of flexible couplings represent couplings designed with a compact structure for industrial applications, torsionally rigid and capable of compensating angular, parallel and combined misalignments.

The special configuration with the single-piece sleeve and the seals at the two ends renders the couplings suitable for use in aggressive environments and in particularly demanding operating conditions. The performance complies with the characteristics of a dual articulation, constant-velocity coupling intended to be used both for general and specific applications and with the possibility of also being mounted on shafts with a large free gap.

The operating limits defined by the maximum torque, by the rotating speed and the permitted angular misalignment are the result of a design based on a targeted choice of materials, the heat treatment and the toothing geometry.

The reliability of the stated operating limits has been confirmed by testing the fatigue limits both at the surface pressure (Hertzian pressure) and at bending and to destructive wear in accordance with calculation schemes based on the most authoritative international standards.

The CHIARAVALLI GROUP SpA Technical Department is available however, to examine problems that relate to the choice, application and maintenance of couplings in collaboration with users.

On specific request, special couplings by their shape, execution and performance can be offered and produced, as an alternative to the normal execution couplings.

For example:

- Couplings designed for high angular and parallel misalignments.
- Couplings manufactured using high resistance steel and with surface hardening heat treatment.
- Couplings with case hardened and hardened hubs and using a hard metal tool).
- Special couplings manufactured to a drawing.

STRUCTURAL CHARACTERISTICS

The GFA range of compact couplings, comprise two toothed hubs and an external connecting single-piece sleeve.

The lubricant seal inside the coupling is ensured by two ring gaskets, arranged at the two ends of the sleeve and held in position by spring washers (Seeger washers).

Two threaded dowels arranged radially on the sleeve in a counter-position allow a solid lubricant to be adopted.

The toothing adopted for the two hubs is profile corrected and has a progressive dual curvature achieved by machine the toothing on a fully Numerically Controlled gear cutting machine.

The sleeve's profile corrected toothing, which has a parallel gene-ratrix, is obtained using a shaping tool.

The toothing is produced to category 7 precision, in compliance with DIN 3972 and has a degree of finish with a surface roughness of not more than Ra = 1.4 micrometres, thanks to the machining technology adopted.

Both the hubs and the sleeve are manufactured using hardened and tempered carbon steel with a tensile stress resistance of 800 N/mm. The couplings are subjected to a surface hardening thermo-chemical treatment at the end of the machining stage, which ensures a high resistance to wear and seizure and also confers a high resistance to corrosion caused by atmospheric agents.

The perfect seal achieved by the gaskets ensures the required lubricant containment and prevents penetration of contaminating elements from outside, thereby contributing to increase the average useful working life of the coupling, even if operating in an aggressive environment.

The two toothed hub bands are positioned at the maximum distance permitted by the sleeve length. This arrangement ensures a minimum angular misalignment for a given parallel misalignment and enhances the coupling's constant-velocity features.



The satisfactory operation and the useful working life of flexible toothed couplings depends on the correct selection of the couplings, as well as on the compatibility of the operating conditions with the performance provided by the coupling. It is essential therefore, to highlight the limiting performance of the couplings and to clarify the actions of the external loads that are exerted on the corresponding couplings.

The basic design ensures that all the couplings are capable of compensating a static angular or assembly misalignment equal to 1 degree and this is ensured by the minimum construction tolerance between the teeth.

The dynamic angular or operating misalignment must never be greater than 0.5 degrees, even if the recommended values should not be greater than 0.25 degrees.

The declared nominal torque values and the maximum rotating speeds indicated refer to an angular or composite misalignment that does not exceed 1/12 of a degree (5 prime divisions).

The 'exceptional' torque values that can be supported as a transient and during the acceleration phases must not be exerted for more than 10-15 seconds and must not occur for more than 5 events/hour.

Fatigue durations are calculated for a conventional limit of 50 million cycles, considering two load cycles for each revolution of the coupling.

Misalignments exceeding 1/8 degrees (7.5 prime divisions) penalise by decreasing the nominal torque and the maximum rotating speed declared for the individual couplings.

The performance of the coupling in terms of torque, limiting speed and useful working life will decrease or increase compared with the declared values in the case of operating conditions that differ from the conditions specified above or for "fixed-term" durations.

The design data has been tested for the purpose of ensuring a reasonable safety margin. The declared performance therefore, is to be understood as valid for a Service Factor equal to 1.

Use of the prescribed lubricants and compliance with the recommended restore time intervals represent the preconditions to achieve the performance as described

in the catalogue. The CHIARAVALLI GROUP SpA Technical Department is available to advise users in selecting the type of coupling most appropriate for the actual operating conditions and to make recommendations in relation to special operating conditions.

TECHNICAL DATA

COUPLING TYPE	Power Factor Kw		Torque Kw Nm		Power transmitted in Kw at r.p.m.				r.p.m. max	r.p.m. recommended limit	max radial misalignment mm	mass kg	J kg cm ²
	normal	except.	normal	except.	750 normal	1000 normal	1500 normal	3000 normal					
GFA 25	0,061	0,157	600	1.524	45	61	91	183	6.000	5.000	0,20	1,36	8,68
GFA 32	0,103	0,259	1.000	2.520	77	103	154	309	5.000	4.000	0,26	2,51	25,10
GFA 40	0,128	0,322	1.250	3.125	96	128	192	384	4.200	3.000	0,32	3,55	44,82
GFA 56	0,257	0,639	2.500	6.200	192	257	385	-	3.500	2.200	0,37	6,15	132,60
GFA 63	0,412	0,985	4.000	9.260	309	412	618	-	3.000	1.600	0,40	9,91	278,20
GFA 80	0,773	1,855	7.500	18.000	579	773	-	-	2.600	1.200	0,48	16,20	558,6
GFA 100	1,236	2,937	12.000	28.500	927	-	-	-	1.400	700	0,65	23,00	1.044,50
GFA 125	2,431	5,795	23.600	56.250	1.823	-	-	-	950	460	0,70	49,15	3.650
GFA 155	4,121	9,273	40.000	90.000	3.090	-	-	-	700	350	0,80	91,30	9.982

N.B. Class G 2.5 dynamic balancing in compliance with ISO 1940 is recommended for actual operating speeds that exceed 3,600 r.p.m. Couplings can operate with a parallel misalignment value that is double the suggested value and assembly with a misalignment value that is four times greater than the suggested value in exceptional cases.

CAD drawings available on our site
www.chiaravalli.com

(1) Referred to the normal coupling complete with maximum bore without keyway.

Quantity, availability and prices
 on B2B Chiaravalli



The torque, speed and useful working life data declared for the couplings are to be understood as valid referred to a Service Factor SF = 1.

The service factor must be determined therefore, based on the type of load, the load intensity and the range factor that characterises the type of load exerted on the coupling.

The values shown in the following table can be considered as a precautionary measure in the absence of reliable service factor design data.

LOAD CONDITION	OPERATING CONDITIONS	TYPE OF DRIVE	
		electric motor	diesel engine
UNIFORM	Regular operation without impacts or overloads	1,25	1,5
LIGHT	Regular operation with minor and infrequent impacts and overloads	1,50	2,0
MEDIUM	Irregular operation with medium overloads for a short duration and frequent but moderate impacts	2,0	2,5
HEAVY	Markedly irregular operation with very frequent impacts and overloads and of major intensity.	2,5	3,0

TEST BASED ON THE POWER TO BE TRANSMITTED

Use the following formula to calculate the value of the operating torque (Me) expressed in Nm, considering the drive motor power output (P) in kW and the operating speed (n) in r.p.m.

$$Me = \frac{9549 \times P}{n}$$

Establish the nominal torque to be transmitted (Mn) based on the service factor taken from the table.

$$Mn = Me \times FS$$

Select the coupling with a nominal torque which is GREATER than the value calculated.

WARNING

The declared nominal torques must be progressively decreased for angular misalignments that exceed 0.125 degrees.

TEST BASED ON THE SHAFT DIAMETER

Check that the largest of the shafts to be connected has a diameter equal to or less than the nominal bore declared for the coupling.

The maximum permitted diameter for the selected coupling should be limited to UNIFORM or LIGHT load conditions.



TEST BASED ON THE ROTATING SPEED

The maximum rotating speed indicated for each coupling represents an operating limit calculated for an angular misalignment that does not exceed 1/12 of a degree. Both the nominal torque and the permitted rotating speed are reduced for greater angular misalignments. Adopt a coefficient equal to 1.12 to increase the service factor and select the coupling as described previously when both the misalignment and the operating speed are less than the suggested reference values, but are close to these values. Contact our Technical Services for operating conditions with misalignments and operating speeds that exceed the suggested reference values.

TEST BASED ON THE REQUIRED USEFUL WORKING LIFE

Nominal operating conditions (torque, misalignment and rotating speed). Operating lifespans that exceed the standard duration cause the nominal torque to decrease.

The service factor must be multiplied by a lifespan coefficient defined as follows if a given operating lifespan, which exceeds the standard working lifespan, is required.

OPERATING LIFESPAN IN HOURS	3800	4000	6000	8000	12000	20000
LIFESPAN COEFFICIENT	1	1,06	1,17	1,26	1,39	1,58

The nominal torque verified for the lifespan must be further decreased in the fairly improbable circumstance in which the actual operating speed is greater than the maximum permitted operating speed for the misalignment conditions of the coupling when in operation.

COMPONENT PARTS OF THE "GIFLEX®" GFA COUPLING

COUPLING TYPE	POS. 1		POS. 2		POS. 3		POS. 4		POS. 5		Allen wrench	N° of pieces
	description	N° of pieces	description	N° of pieces	Seal ring Corteco NBR DIN 3760 A	N° of pieces	Flexible ring for bores DIN 472	N° of pieces	Flat dowel UNI 5923	N° of pieces		
GFA 25	sleeve	1	HUB	2	BA 42x56x7	2	56 I	2	M 6x8	2	D.3	1
GFA 32	sleeve	1	HUB	2	BA 56x72x8	2	72 I	2	M 6x8	2	D.3	1
GFA 40	sleeve	1	HUB	2	BA 64x80x8	2	80 I	2	M 6x8	2	D.3	1
GFA 56	sleeve	1	HUB	2	BA 80x100x10	2	100 I	2	M 6x8	2	D.3	1
GFA 63	sleeve	1	HUB	2	BA 100x125x12	2	125 I	2	M 6x8	2	D.3	1
GFA 80	sleeve	1	HUB	2	BA 125x160x12	2	160 I	2	M 6x8	2	D.3	1
GFA 100	sleeve	1	HUB	2	SMIM 150x180x12	2	180 I	2	M 6x8	2	D.3	1
GFA 125	sleeve	1	HUB	2	SM 190x220x15	2	220 I	2	M 6x8	2	D.3	1
GFA 155	sleeve	1	HUB	2	SMIM 240x280x15	2	280 I	2	M 6x8	2	D.3	1

COMPONENT PARTS OF THE "GIFLEX®" GFAS COUPLING

COUPLING TYPE	POS. 1		POS. 2		POS. 3		POS. 4		POS. 5		Allen wrench	N° of pieces
	description	N° of pieces	description	N° of pieces	Seal ring Serie UM Gaco NBR	N° of pieces	Flexible ring for bores DIN 471	N° of pieces	Flat dowel UNI 5923	N° of pieces		
GFAS 25	sleeve	1	HUB	1	UM 60x40x10	1	40 E	1	M 6x8	2	D.3	1
GFAS 32	sleeve	1	HUB	1	UM 75x55x10	1	55 E	1	M 6x8	2	D.3	1
GFAS 40	sleeve	1	HUB	1	UM 85x65x10	1	65 E	1	M 6x8	2	D.3	1
GFAS 56	sleeve	1	HUB	1	UM 100x80x10	1	80 E	1	M 6x8	2	D.3	1
GFAS 63	sleeve	1	HUB	1	UM 120x100x10	1	100 E	1	M 6x8	2	D.3	1
GFAS 80	sleeve	1	HUB	1	UM 155x125x15	1	125 E	1	M 6x8	2	D.3	1
GFAS 100	sleeve	1	HUB	1	UM 180x150x15	1	150 E	1	M 6x8	2	D.3	1



NORMAL HUB



LONG HUB



SLEEVE STEEL

GFA ASSEMBLY

- A)** Insert the stop ring (4) and the seal ring (2) on the shaft.
- B)** Assemble the hubs (2) on the relative shafts.
- C)** Sleeve (1) is to be fitted on the longest shaft.
- D)** Position the shafts close together and check that the distance G corresponds to the value indicated in the table.
- E)** Align the shafts and check the parallelism then tighten the hubs on the shaft.
- F)** Fill the tothing and the gap between the hubs with grease.
- G)** At this stage slide the sleeve (1) down and position the sealing rings (3) in its place and tighten the stop rings (4) in their seat.
- H)** Proceed as follows for disassembly: remove the stop rings (4) using a pair of pliers, separate the sleeve (1) from the hubs (2) and the GFA coupling is fully disassembled.

MAINTENANCE

Unscrew both plugs (5) then introduce grease using the grease gun through the greasing holes until the grease exits from the other hole positioned at 180°. Replace the plugs. Repeat this operation every 1.000 working hours.

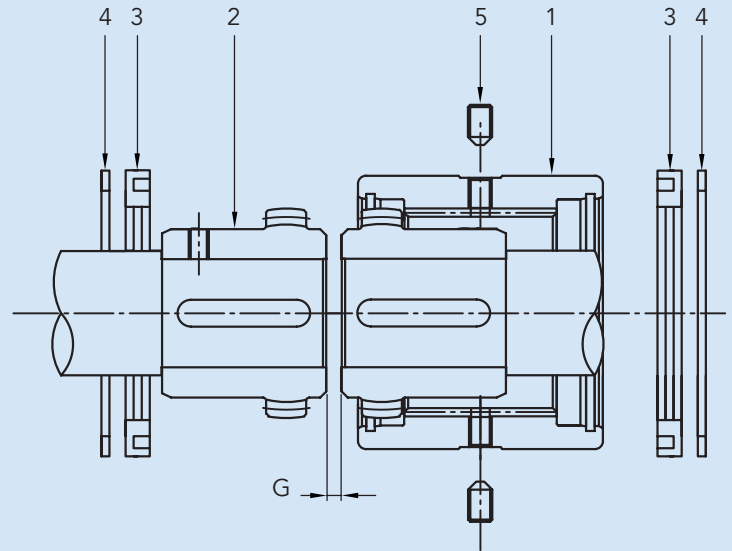
Equivalent recommended greases are as follows:

TYPE	PRODUCER
Sovarex L-O	MOBIL OIL
Gulfrown EP-O	GULF OIL
Alesia EP-2	SHELL OIL
....

Couplings require lubrication with grease, the quantity of grease used should half fill the available gap.

Use of Lithium soap grease with a base mineral oil and consistency index 2 (in compliance with NLGI) is recommended for moderate loads and normal operating conditions.

Use Barium complex soap grease, PAO synthetic base oil and consistency index 2 for heavy-duty operating conditions as regards temperatures and with heavy loads.

Contact the CHIARAVALLI GROUP SpA Technical Department for extreme operating conditions.

The lubricant complying with the formulation and with the recommended characteristics can be selected from among the range of products indicated below by consulting the Producer.

N.B.

The technical characteristics, the dimensions and all other data contained in this catalogue are not binding.

CHIARAVALLI GROUP SpA reserves the right to change the measurements indicated at any time and without notice.



STEEL SLEEVE

INTERPRETATION CODES

EXAMPLE

GFA 25-NN with 2 normal hubs

GFA 25-NL with 1 normal hubs
and 1 long hub

GFA 25-LL with 2 long hubs

The characteristic size of the coupling is defined by the maximum diameter bore.

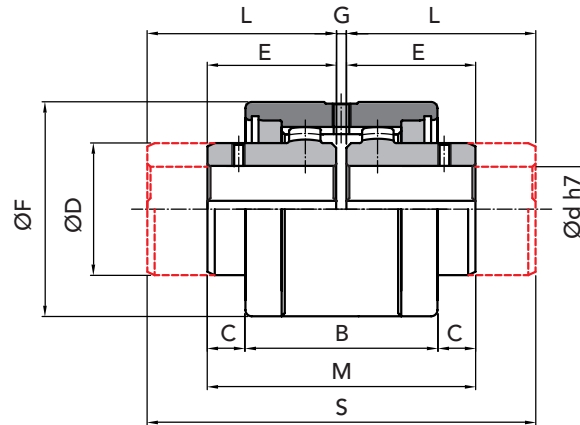

PART NUMBERS FOR COMPLETE COUPLING

PART NUMBERS FOR SIMPLE COMPONENTS

COUPLING TYPE	P. NUMBER GFA NN	P. NUMBER GFA NL	P. NUMBER GFA LL	SLEEVE	HUB NORMAL	HUB LONG	COMPONENTS to assembled coupling
GFA 25	00202502	00202500	00202504	00202510	00202520	00202540	00202560
GFA 32	00203202	00203200	00203204	00203210	00203220	00203240	00203260
GFA 40	00204002	00204000	00204004	00204010	00204020	00204040	00204060
GFA 56	00205602	00205600	00205604	00205610	00205620	00205640	00205660
GFA 63	00206302	00206300	00206304	00206310	00206320	00206340	00206360
GFA 80	00208002	00208000	00208004	00208010	00208020	00208040	00208060
GFA 100	00210002	00210000	00210004	00210010	00210020	00210040	00210060
GFA 125	00212502	00212500	00212504	00212510	00212520	00212540	00212560
GFA 155	00215502	00215502	00215504	00215510	00215520	00215540	00215560

MEASUREMENTS - WEIGHTS

COUPLING TYPE	Ø bore nom.	Ød available holes with H7 tolerance		measures in mm									Kg		
		ON REQUEST		normal series						long series			sleeve	HUB normal	HUB long
		min	max	B	C	ØD	E	ØF	G	M	L	S			
GFA 25	-	25	28	61	12	42	41	68	3	85	60	123	0,72	0,48	0,69
GFA 32	-	32	38	73	13,5	55	48,5	85	3	100	80	163	1,14	0,99	1,58
GFA 40	-	40	48	82	16,5	64	56	95	3	115	80	163	1,68	1,49	2,10
GFA 56	-	56	60	97	21,5	80	68	120	4	140	100	204	2,86	2,96	4,22
GFA 63	-	63	70	108	22,5	100	74,5	140	4	153	119,5	243	3,75	4,90	7,67
GFA 80	-	80	90	125	22,5	125	82,5	175	5	170	140	285	5,58	8,72	14,26
GFA 100	-	100	110	148	34	150	105	198	6	216	174,5	355	6,63	15,76	25,40
GFA 125*	40	125	140	214	39	190	140	245	8	288	207,5	423	17,70	32,60	49,50
GFA 155*	40	155	175	240	64	240	180	300	10	370	245	498	28,30	65,50	91,40

* Row material quenched steel 39NiCrMo3



On request: we execute machining for finish bore and keyway.

IMPORTANT

The GFA couplings can be ordered complete or for single items.

CAD drawings available on our site
www.chiaravalli.com

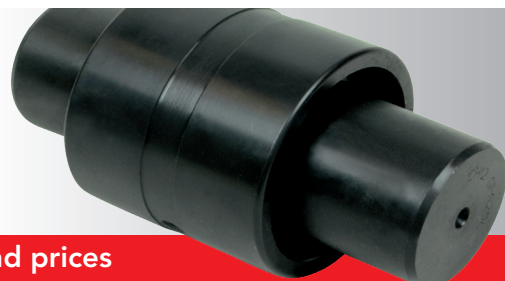

Quantity, availability and prices
on B2B Chiaravalli

FLEXIBLE TOOTHED COUPLINGS WITH DUAL CURVATURE "GIFLEX" SERIES GFA with STEEL SLEEVE



SERIES GFAS



GFAS COUPLING WITH STEEL BELL



PRESENTATION

The "GIFLEX®" GFAS range of flexible couplings represent couplings designed with a compact structure for industrial applications, torsionally rigid and capable of compensating angular, parallel and combined misalignments.

The special configuration with the single-piece sleeve and the seals at the two ends renders the couplings suitable for use in aggressive environments and in particularly demanding operating conditions. The performance complies with the characteristics of a dual articulation, constant-velocity coupling intended to be used both for general and specific applications and with the possibility of also being mounted on shafts with a large free gap.

The operating limits defined by the maximum torque, by the rotating speed and the permitted angular misalignment are the result of a design based on a targeted choice of materials, the heat treatment and the toothing geometry.

The reliability of the stated operating limits has been confirmed by testing the fatigue limits both at the surface pressure (Hertzian pressure) and at bending and to destructive wear in accordance with calculation schemes based on the most authoritative international standards.

The CHIARAVALLI GROUP SpA Technical Department is available however, to examine problems that relate to the choice, application and maintenance of couplings in collaboration with users.

On specific request, special couplings by their shape, execution and performance can be offered and produced, as an alternative to the normal execution couplings.

For example:

- Couplings designed for high angular and parallel misalignments.
- Couplings manufactured using high resistance steel and with surface hardening heat treatment.
- Couplings with case hardened and hardened hubs and toothing finished by machine tools after heat treatment (skiving using a hard metal tool).
- Special couplings manufactured to a drawing.

STRUCTURAL CHARACTERISTICS

The GFAS range of compact couplings, comprise two toothed hubs and an external connecting single-piece sleeve.

The lubricant seal inside the coupling is ensured by two ring gaskets, arranged at the two ends of the sleeve and held in position by spring washers (Seeger washers).

Two threaded dowels arranged radially on the sleeve in a counter-position allow a solid lubricant to be adopted.

The toothing adopted for the two hubs is profile corrected and has a progressive dual curvature achieved by machine the toothing on a fully Numerically Controlled gear cutting machine.

The sleeve's profile corrected toothing, which has a parallel generatrix, is obtained using a shaping tool.

The toothing is produced to category 7 precision, in compliance with DIN 3972 and has a degree of finish with a surface roughness of not more than $Ra = 1.4$ micrometres, thanks to the machining technology adopted.

Both the hubs and the sleeve are manufactured using hardened and tempered carbon steel with a tensile stress resistance of 800 N/mm. The couplings are subjected to a surface hardening thermo-chemical treatment at the end of the machining stage, which ensures a high resistance to wear and seizure and also confers a high resistance to corrosion caused by atmospheric agents. The perfect seal achieved by the gaskets ensures the required lubricant containment and prevents penetration of contaminating elements from outside, thereby contributing to increase the average useful working life of the coupling, even if operating in an aggressive environment.

The two toothed hub bands are positioned at the maximum distance permitted by the sleeve length. This arrangement ensures a minimum angular misalignment for a given parallel misalignment and enhances the coupling's constant-velocity features.



The satisfactory operation and the useful working life of flexible toothed couplings depends on the correct selection of the couplings, as well as on the compatibility of the operating conditions with the performance provided by the coupling. It is essential therefore, to highlight the limiting performance of the couplings and to clarify the actions of the external loads that are exerted on the corresponding couplings.

The basic design ensures that all the couplings are capable of compensating a static angular or assembly misalignment equal to 1 degree and this is ensured by the minimum construction tolerance between the teeth.

The dynamic angular or operating misalignment must never be greater than 0.5 degrees, even if the recommended values should not be greater than 0.25 degrees.

The declared nominal torque values and the maximum rotating speeds indicated refer to an angular or composite misalignment that does not exceed 1/12 of a degree (5 prime divisions).

The 'exceptional' torque values that can be supported as a transient and during the acceleration phases must not be exerted for more than 10-15 seconds and must not occur for more than 5 events/hour.

Fatigue durations are calculated for a conventional limit of 50 million cycles, considering two load cycles for each revolution of the coupling.

Misalignments exceeding 1/8 degrees (7.5 prime divisions) penalise by decreasing the nominal torque and the maximum rotating speed declared for the individual couplings.

The performance of the coupling in terms of torque, limiting speed and useful working life will decrease or increase compared with the declared values in the case of operating conditions that differ from the conditions specified above or for "fixed-term" durations.

The design data has been tested for the purpose of ensuring a reasonable safety margin. The declared performance therefore, is to be understood as valid for a Service Factor equal to 1.

Use of the prescribed lubricants and compliance with the recommended restore time intervals represent the preconditions to achieve the performance as described

in the catalogue. The CHIARAVALLI GROUP SpA Technical Department is available to advise users in selecting the type of coupling most appropriate for the actual operating conditions and to make recommendations in relation to special operating conditions.

TECHNICAL DATA

COUPLING TYPE	Power Factor Kw		Torque Kw Nm		Power transmitted in Kw at r.p.m.				r.p.m. max	r.p.m. recommended limit	max radial misalignment mm	mass kg	J kg cm ²
	normal	except.	normal	except.	750 normal	1000 normal	1500 normal	3000 normal					
GFAS 25	0,061	0,157	600	1.524	45	61	91	183	6.000	5.000	-	1,35	7,31
GFAS 32	0,103	0,259	1.000	2.520	77	103	154	309	5.000	4.000	-	2,43	19,15
GFAS 40	0,128	0,322	1.250	3.125	96	128	192	384	4.200	3.000	-	3,64	34,13
GFAS 56	0,257	0,639	2.500	6.200	192	257	385	-	3.500	2.200	-	6,07	96,56
GFAS 63	0,412	0,985	4.000	9.260	309	412	618	-	3.000	1.600	-	10,00	207,32
GFAS 80	0,773	1,855	7.500	18.000	579	773	-	-	2.600	1.200	-	19,18	492,6
GFAS 100	1,236	2,937	12.000	28.500	927	-	-	-	1.400	700	-	28,00	1.064,00

N.B. Class G 2.5 dynamic balancing in compliance with ISO 1940 is recommended for actual operating speeds that exceed 3,600 r.p.m. Couplings can operate with a parallel misalignment value that is double the suggested value and assembly with a misalignment value that is four times greater than the suggested value in exceptional cases.

CAD drawings available on our site
www.chiaravalli.com

(1) Referred to the normal coupling complete with maximum bore without keyway.

Quantity, availability and prices
 on B2B Chiaravalli



NORMAL HUB



LONG HUB



NORMAL CONE



LONG CONE

GFAS ASSEMBLY

- A)** The seal ring (3) and stop ring (4) are already fitted on the extractable hub (2).
- B)** Assembly in closed cone mode only requires the sleeve (1) to be fixed onto one shaft and the extractable hub (2) to be tightened on the other shaft.
- C)** Then arrange the shafts to be connected closely together, positioning the hub (2) over the sleeve (1).
- D)** To disassemble, separate the shafts then extract the hub (2) from the sleeve (1).

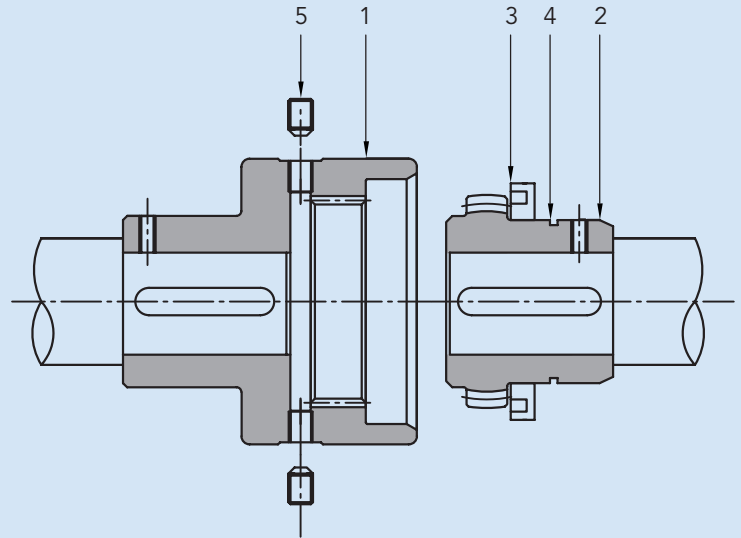
Equivalent recommended greases are as follows:

TYPE	PRODUCER
Sovarex L-O	MOBIL OIL
Gulfrown EP-O	GULF OIL
Alesia EP-2	SHELL OIL
....

Couplings require lubrication with grease, the quantity of grease used should half fill the available gap.

Use of Lithium soap grease with a base mineral oil and consistency index 2 (in compliance with NLGI) is recommended for moderate loads and normal operating conditions.

Use Barium complex soap grease, PAO synthetic base oil and consistency index 2 for heavy-duty operating conditions as regards temperatures and with heavy loads.

Contact the CHIARAVALLI GROUP SpA Technical Department for extreme operating conditions.

The lubricant complying with the formulation and with the recommended characteristics can be selected from among the range of products indicated below by consulting the Producer.

N.B.

The technical characteristics, the dimensions and all other data contained in this catalogue are not binding.

CHIARAVALLI GROUP SpA reserves the right to change the measurements indicated at any time and without notice.



CONE IN STEEL

INTERPRETATION CODES

Example

- GFAS 25-NN** with cone and a normal hub
- GFAS 25-NL** with cone and a long hub
- GFAS 25-LL** with long cone and a long hub
- GFAS 25-LN** with long cone and a normal hub

The characteristic size of the coupling is defined by the maximum diameter bore.

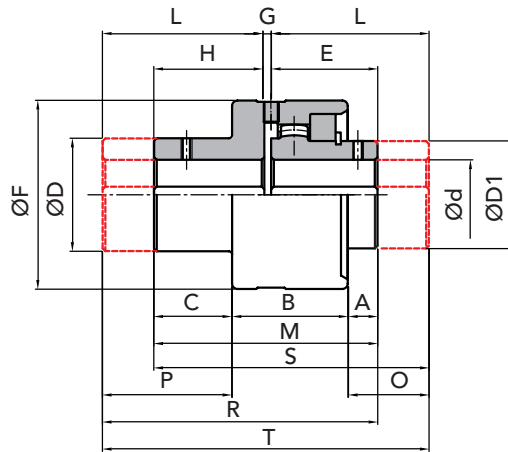

PART NUMBERS FOR COMPLETE COUPLING

PART NUMBERS FOR SIMPLE COMPONENTS

COUPLING TYPE	P.NUMBER GFAS NN	P.NUMBER GFAS NL	P.NUMBER GFAS LN	P.NUMBER GFAS LL	CONE NORMAL	CONE LONG	HUB NORMAL	HUB LONG	COMPONENTS to assembled coupling
GFAS 25	00302502	00302500	00302506	00302504	00302510	00302511	00302520	00302540	00302560
GFAS 32	00303202	00303200	00303206	00303204	00303210	00302511	00303220	00303240	00303260
GFAS 40	00304002	00304000	00304006	00304004	00304010	00304011	00304020	00304040	00304060
GFAS 56	00305602	00305600	00305606	00305604	00305610	00305611	00305620	00305640	00305660
GFAS 63	00306302	00306300	00306306	00306304	00306310	00306311	00306320	00306340	00306360
GFAS 80	00308002	00308000	00308006	00308004	00308010	00308011	00308020	00308040	00308060
GFAS 100	00310002	00310000	00310006	00310004	00310010	00310011	00310020	00310040	00310060

MEASUREMENTS - WEIGHTS

COUPLING TYPE	without bore		Ød finished bore		measures in mm																Kg			
	min	max	min	max	normal series								long series								normal bell	normal HUB	long bell	long HUB
					A	B	C	ØD	ØD1	E	ØF	G	H	M	I	L	O	P	R	S				
GFAS 25	-	25	28	13	43	29	42	40	41	70	3	41	85	60	60	32	48	104	104	123	1,03	0,48	1,30	0,69
GFAS 32	-	32	38	16	49	35	55	55	48,5	85	3	48,5	100	80	80	47,5	66,5	131,5	131,5	163	1,75	0,99	2,50	1,58
GFAS 40	-	40	48	18,5	54,5	42	64	64	56	95	3	56	115	80	80	42,5	66	139	139	163	2,71	1,49	3,40	2,10
GFAS 56	-	56	60	27	60	45	80	80	68	120	4	60	132	100	100	59	85	172	164	204	4,43	2,96	6,10	4,22
GFAS 63	-	63	75	31	63	46	100	100	74,5	140	4	61,5	140	119,5	119,5	76	104	198	185	243	6,62	4,90	10,20	7,67
GFAS 80	-	80	90	26	76	51	125	125	82,5	175	5	65,5	153	138	140	83,5	123,5	225,5	210,5	283	10,50	8,68	17,90	14,22
GFAS 100	-	100	110	38	92	71	150	150	105	198	6	90	201	162	174,5	107,5	143	273	270,5	342,5	28,2	15,70	38,1	25,30

GFAS NN

GFAS NL

GFAS LL

GFAS LN

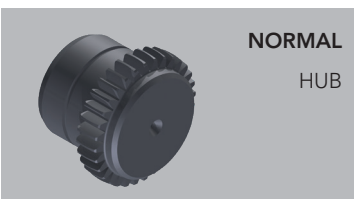
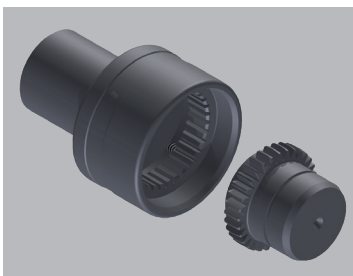
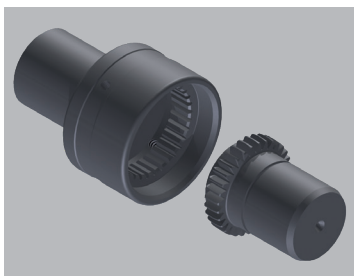
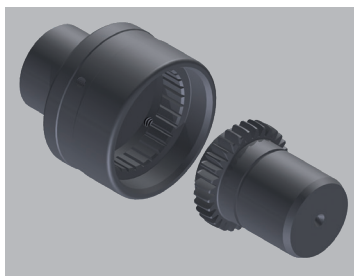

NORMAL HUB

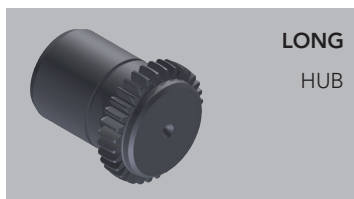

LONG HUB



NORMAL BELL

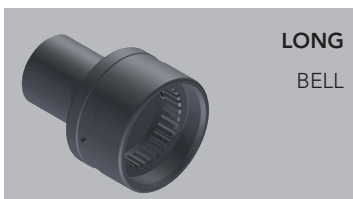

LONG BELL

IMPORTANT

The GFAS couplings can be ordered complete or for single items.



CAD drawings available on our site
www.chiaravalli.com

Quantity, availability and prices on B2B Chiaravalli



FLEXIBLE TOOTHED COUPLINGS WITH NYLON SLEEVE

FLEXIBLE TOOTHED COUPLINGS WITH NYLON SLEEVE "GIFLEX®" SERIES FBX

SERIES FBX



GIFLEX® FBX COUPLING WITH NYLON SLEEVE



NORMAL HUB



LONG HUB

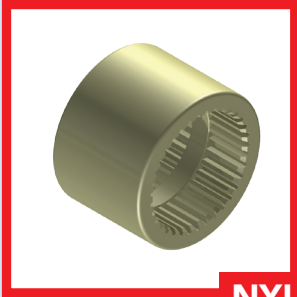

NYLON SLEEVE



COUPLING SELECTION

Torque based selection:
the coupling must be selected in order that the maximum torque motor does not exceed the coupling's permitted twisting moment peak.

TECHNICAL DATA

COUPLING TYPE	Power factor Kw r.p.m.		Torque Nm		power transmitted in kw at r.p.m.								r.p.m. max	mass kg	J kg cm ²	Maximum misalignment for each hub		Axial displacement mm
	norm	max	norm	max	750		1000		1500		3000					Angular α	Radial mm	
					norm	max	norm	max	norm	max	norm	max						
FBX 14	0,0010	0,0 020	10	20	0,80	1,56	1,05	2,10	1,58	3,14	3,12	6,24	14.000	0,12	0,27	± 2°	0,7	± 1
FBX 19	0,0017	0,0033	16	32	1,25	2,50	1,67	3,34	2,52	5,02	5,04	10,08	12.000	0,19	0,55	± 2°	0,8	± 1
FBX 24	0,0021	0,0042	20	40	1,58	3,15	2,10	4,20	3,14	6,28	6,26	12,52	10.500	0,23	0,96	± 2°	0,8	± 1
FBX 28	0,0047	0,0092	45	90	3,52	7,07	4,72	9,43	7,08	14,12	14,14	28,28	8.500	0,59	3,20	± 2°	1	± 1
FBX 32	0,0063	0,0127	60	120	4,70	9,43	6,28	12,58	9,40	18,85	18,83	37,66	7.500	0,78	5,60	± 2°	1	± 1
FBX 38	0,0084	0,0168	80	160	6,28	12,57	8,38	16,76	12,56	25,12	25,12	50,24	6.500	0,95	9,59	± 2°	0,9	± 1
FBX 42	0,0105	0,0210	100	200	7,85	15,72	10,47	20,93	15,70	31,40	31,42	62,84	6.000	1,32	13,90	± 2°	0,9	± 1
FBX 48	0,0147	0,0292	140	280	11,00	22,00	14,67	29,32	22,00	43,98	43,96	87,92	5.600	1,53	18,15	± 2°	0,9	± 1
FBX 55	0,0280	0,0565	275	555	20,80	39,50	27,80	52,00	42,50	85,00	84,60	169,20	4.800	2,30	49,44	± 2°	1,2	± 1
FBX 65	0,0398	0,0798	380	760	29,85	59,70	39,78	79,58	59,70	119,36	119,37	238,74	4.000	3,25	108,40	± 2°	1,3	± 1



NYLON SLEEVE

INTERPRETATION CODES

Example

FBX 19-NN with 2 normal hubs

FBX 19-NL with 1 normal hubs
and 1 long hub

FBX 19-LL with 2 long hubs

The characteristic size of the coupling is defined by the maximum diameter bore.

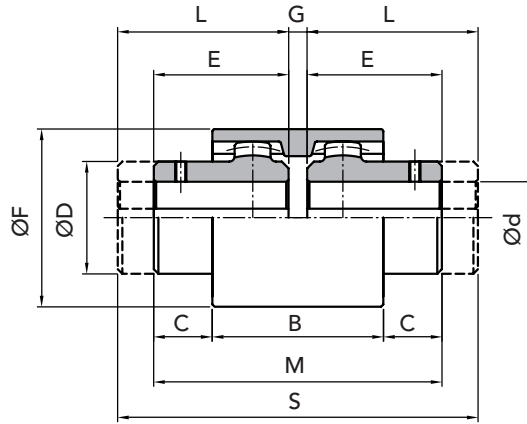

PART NUMBERS

COUPLING TYPE	PART NUMBER FBX NN	PART NUMBER FBX NL	PART NUMBER FBX LL	HUB NORMAL	HUB LONG	NYLON SLEEVE
FBX 14	00501402	00501400	00501404	00501420	00501440	00501410
FBX 19	00501902	00501900	00501904	00501920	00501940	00501910
FBX 24	00502402	00502400	00502404	00502420	00502440	00502410
FBX 28	00502802	00502800	00502804	00502820	00502840	00502810
FBX 32	00503202	00503200	00503204	00503220	00503240	00503210
FBX 38	00503802	00503800	00503804	00503820	00503840	00503810
FBX 42	00504202	00504200	00504204	00504220	00504240	00504210
FBX 48	00504802	00504800	00504804	00504820	00504840	00504810
FBX 55	00505502	00505500	00505504	00505520	00505540	00505510
FBX 65	00506502	00506500	00506504	00506520	00506540	00506510

MEASUREMENTS - WEIGHTS

COUPLING TYPE	hub without hole	Ød finished bore		measurement in mm									Kg SLEEVE	HUB normal	HUB long
		min.	max.	normal series					long series						
				B	C	ØD	E	ØF	G	M	L	S			
FBX 14	-	6	14	37	6,5	25	23	40	4	50	40	84	0,02	0,06	0,10
FBX 19	-	8	19	37	8,5	32	25	48	4	54	40	84	0,03	0,09	0,13
FBX 24	-	10	24	41	7,5	36	26	52	4	56	50	104	0,04	0,11	0,21
FBX 28	-	10	28	46	19	44	40	66	4	84	55	114	0,07	0,28	0,38
FBX 32	-	12	32	48	18	50	40	76	4	84	60	114	0,09	0,37	0,50
FBX 38	-	14	38	48	18	58	40	83	4	84	60	124	0,11	0,46	0,70
FBX 42	-	20	42	50	19	65	42	92	4	88	60	124	0,14	0,64	0,90
FBX 48	-	20	48	50	27	68	50	95	4	104	60	124	0,16	0,74	1,00
FBX 55	-	25	55	58	25	82	52	114	4	108	65	134	0,26	1,12	1,41
FBX 65	-	25	65	68	23	96	55	132	4	114	70	144	0,39	1,59	2,04

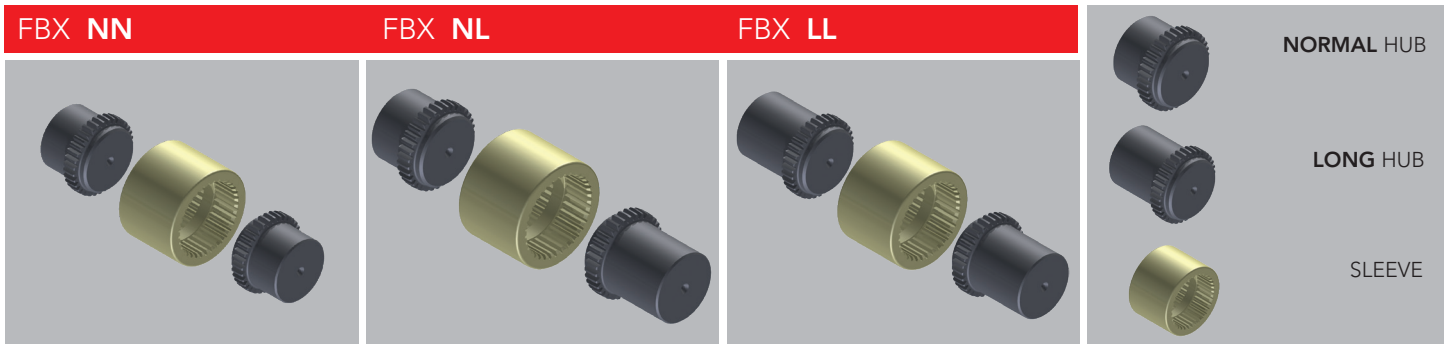

IMPORTANT

The FBX couplings can be ordered complete or for single items.

CAD drawings available on our site
www.chiaravalli.com

Quantity, availability and prices
 on B2B Chiaravalli

FLEXIBLE TOOTHED COUPLINGS WITH NYLON SLEEVE "GIFLEX®" SERIES FBX



The Manufacturer DISTRIBUTOR



B2B next

*Chiaravalli Group SpA
E-commerce service*

FAST TRACK

*Daily Shipments
by air*



PRIORITY TRUCK SERVICE

Truck priority Shipments

ADVANCED SHIPPING

*Thirty hours Shipments
by air or truck*



YOUR SINGLE NEED IS OUR PRIORITY

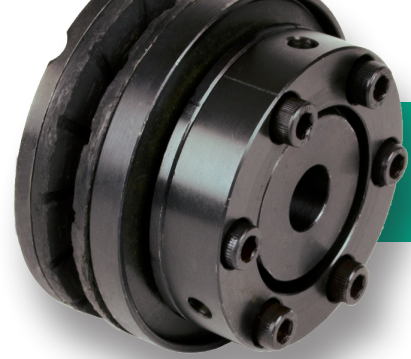

TORQUE LIMITERS

TORQUE LIMITERS

page 43

TORQUE LIMITERS
WITH CHAIN COUPLING LCG

47

CHAIN COUPLING
WITH KC COVER

48



FRICTION TORQUE LIMITERS

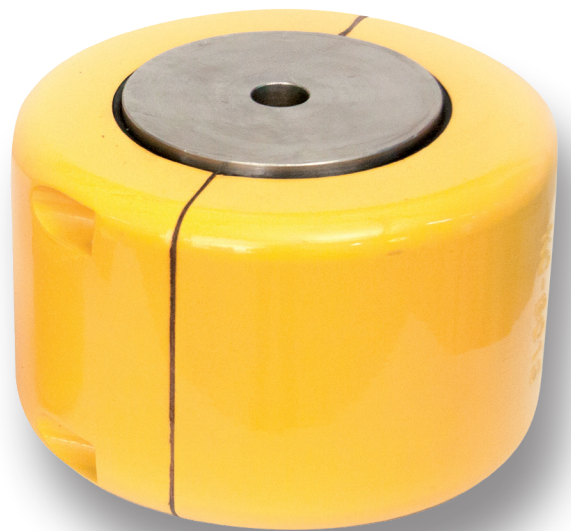
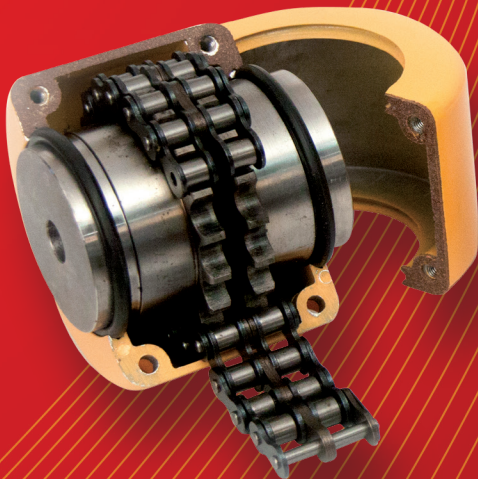

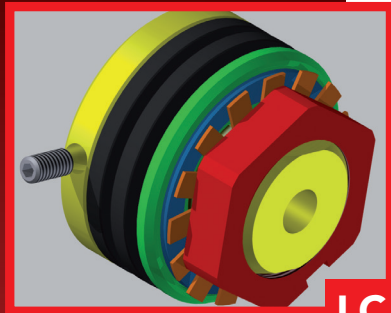

LC 40 - 1

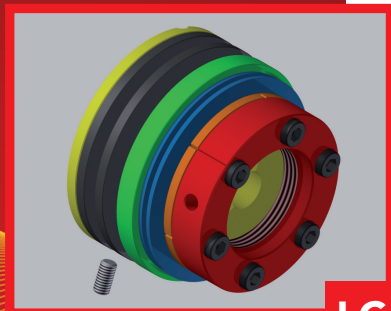
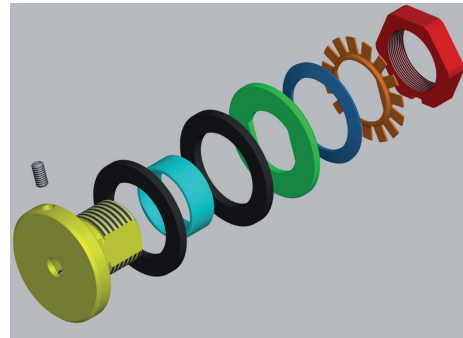

LC 85 - 2

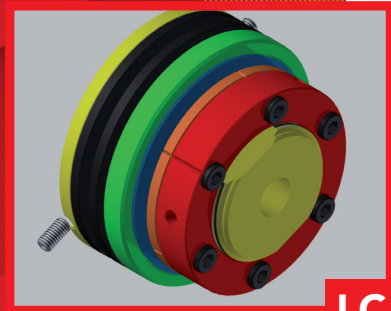
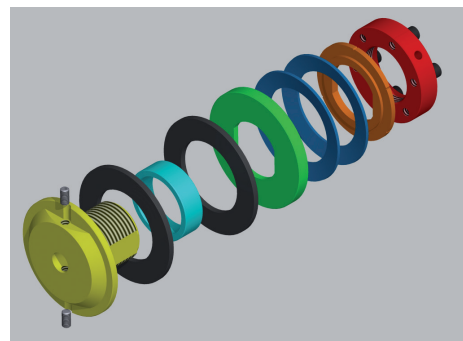

LC 95 - 1

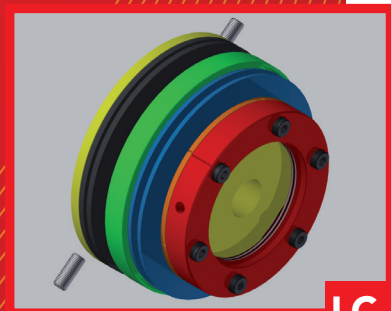
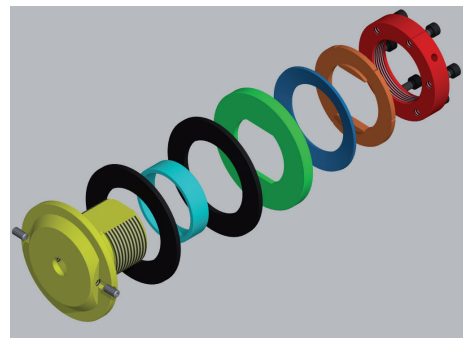

LC 170 - 2

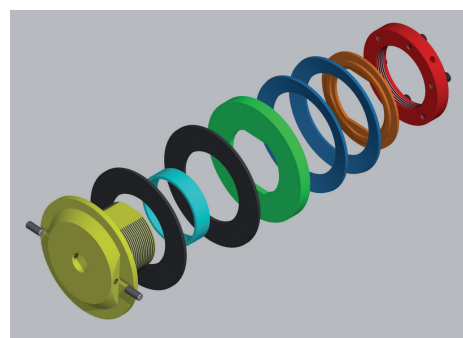



The torque limiter finds employment where an overloaded protection on mechanic transmission components is necessary (kinematics and machines).

The employment system easy and efficient, offers full operative reliability when the required torque exceeds the preloaded value and automatically restores the transmission when the overloaded ceases.

The transmission mechanical component, between pulleys, chain wheels and gears is within clutch that elements that tighten through the compression of the Bauer springs develops a friction force defined by the clamping of the sleeve.

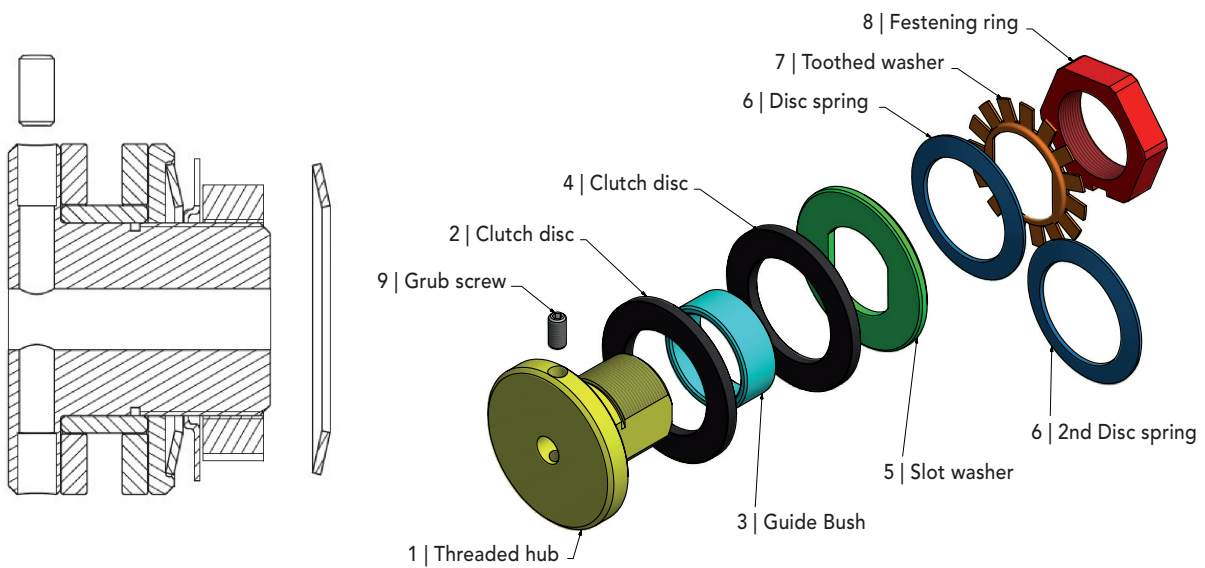

LC 40-50

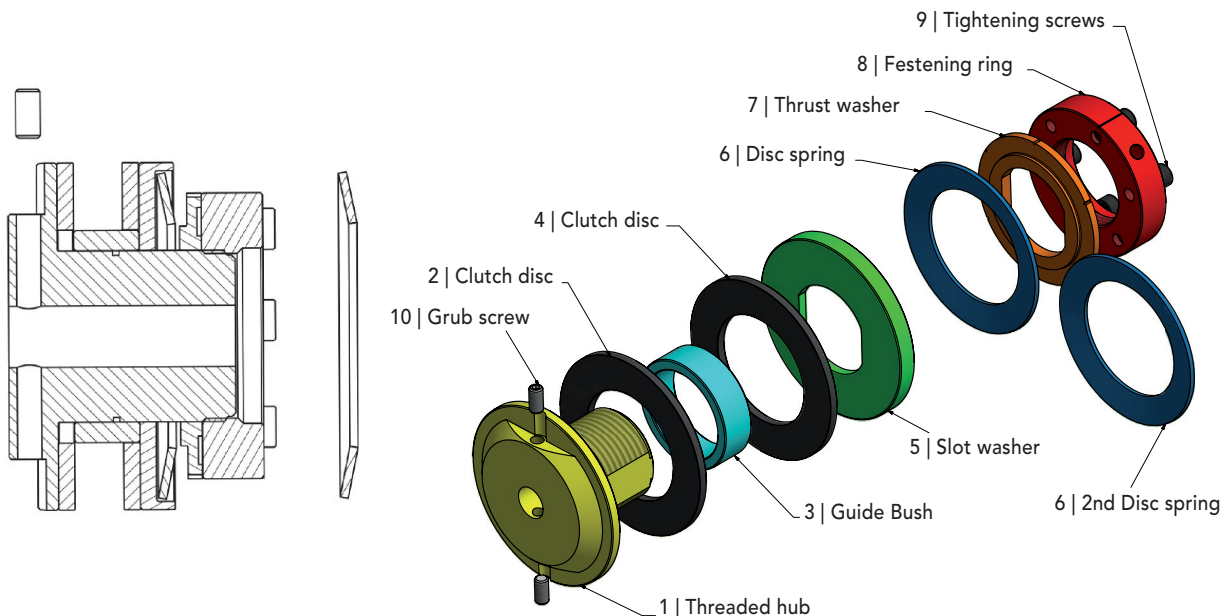

LC 65-85-95-120-140-170



CHOICE OF THE TORQUE LIMITER:

Tkw = Power in kW
 n = revolutions per minut
 Mt = torque (Nm)

The torque is given by the relation:

$$Mt = \frac{9550 \cdot Tkw}{n}$$

Example:

To use an electrical motor with the following features:

Power 4 kW e n = 1.550 g/1'

$$Mt = \frac{9550 \cdot 4}{1550} = 24.64 \text{ Nm}$$

So we will choose a limiter with a torque equal to or higher than 24,64 Nm



1 spring

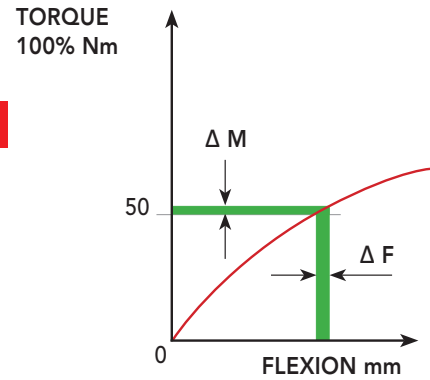

2 springs

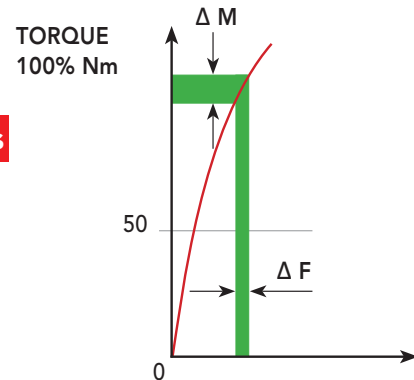

Scheme of the Belleville springs DIN 2093

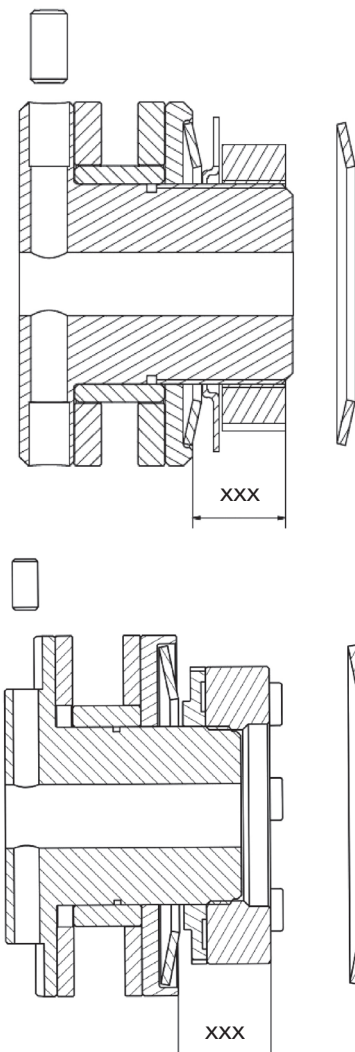

TYPE	TORQUE N/m	SPRINGS	R mm
LC 40	15	1	0,59
	28	2	0,53
LC 50	32	1	0,72
	60	2	0,57
LC 65	70	1	0,65
	120	2	0,55
LC 85	130	1	1,65
	240	2	1,35
LC 95	190	1	1,15
	340	2	0,95
LC 120	350	1	2
	650	2	1,75
LC 140	650	1	2,1
	1200	2	1,85
LC 170	1000	1	2,3
	1800	2	1,95

Manually tighten the nut until closing (xxx).

To get the maximum torque use the wrench to tighten further (xxx-R).

The ring nut is held in position by tightening screws.

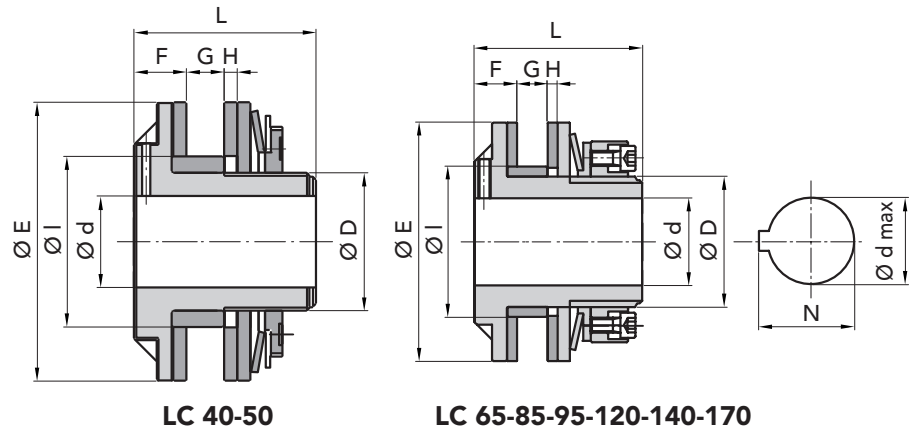

The CHIARAVALLI limiter is assembled with a single spring.
The second spring is also present in the KIT.

LC 40-50
LC 65-85-95-120-140-170

TYPE	Limiter part number	Dished plate spring part number	Disk Friction part number	Part number bushing	ØE	ØIh8	Ød	F	G	H	ØD	L	max. bore keyway DIN 6885/1 on request		Max torque N/m	N° of springs	sprockets for chain (u) = 1,6 : 2		Weight Kg.
													Ød max	N			Ø pitch for roller	N° teeth	
LC 40	08040000	08040050	08040020	08040030	40	26	7	9	6	3	22	30	14	16,3	15	1	3/8" x 6,65	18-21	0,190
																	1/2" x 8,51	15	0,195
LC 50	08050000	08050050	08050020	08050030	50	35	7	10	6	3	32	35,5	20	22,8	30	1	3/8" x 6,65	19-23	0,365
																	1/2" x 8,51	17	0,370
LC 65	08065000	08065050	08065020	08065030	65	45	10	16	9	4	36	53	22	24,8	70	1	3/8" x 6,65	27	0,750
												55					120	2	1/2" x 8,51
LC 85	08085000	08085050	08085020	08085030	85	52	15	16	11	4	45	59	25	28,3	130	1	3/8" x 6,65	38	1,470
												61					240	2	1/2" x 8,51
LC 95	08095000	08095050	08095020	08095030	95	60	15	17	11	4	52	67	35	38,3	190	1	1/2" x 8,51	30	2,160
																	340	2	5/8" x 10,16
LC 120	08120000	08120050	08120020	08120030	120	73	20	19	16	4	64	78	45	48,8	350	1	1/2" x 8,51	38	4,000
																	650	2	5/8" x 10,16
LC 140	08140000	08140050	08140020	08140030	140	90	20	22	17	4	85	86,5	60	64,4	650	1	3/4" x 12,07	35	5,900
																	1200	2	1" x 15,88
LC 170	08170000	08170050	08170020	08170030	170	100	28	25,5	18,5	4,5	90	94	65	69,4	1000	1	3/4" x 12,07	35	9,200
																	1800	2	1" x 15,88
																	1" 1/4 x 19,05	22	9,400

Pay attention. You are strongly advised to use the torque limiters of the series LC Cleaning, checking carefully that products or oily liquids in general do not reach in any way the friction materials in order to not cause a sudden and inevitable performance degradation. Adjust the guide bush according to their needs. The clutch plates are constituted by a structure that is absolutely free of asbestos.

CAD drawings available on our site
www.chiaravalli.com

Quantity, availability and prices
on B2B Chiaravalli





- LC Torque limiter connected to the coaxial pinion hub through a double chain.
- Easy adjustment of desired torque through lock nut.
- The two friction elements dished clutch are burnished.

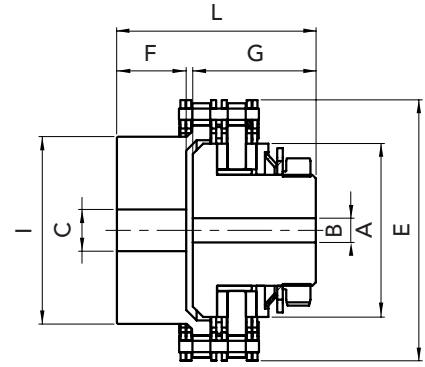
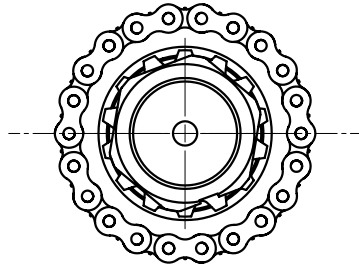

TORQUE LIMITERS WITH CHAIN COUPLING LCG

TYPE	PART NUMBER	max. torque	N° springs	A	B	B max	C max	C max	E	F	G	I	L	DIS. mm	ang.	chain pitch	Z teeth	weight Kg
LCG 50	08050000	30	1	50	7	20	12	30	75,19	20	35	45	57	0,20	30°	3/8" X 7/32"	22	1,000
		55	2															1,005
LCG 65	08065000	70	1	65	10	22	16	35	97,03	33	50	65	85	0,25	30°	1/2" X 5/16"	21	2,500
		120	2															2,550
LCG 85	08085000	130	1	85	15	25	20	45	121,25	36	55	85	94	0,30	30°	5/8" X 3/8"	21	4,300
		240	2															4,300
LCG 95	08095000	190	1	95	15	35	20	55	131,88	38	67	95	108	0,35	30°	3/4" X 7/16"	19	6,000
		340	2															6,010
LCG 120	08120000	350	1	120	20	45	20	60	168,13	47	78	120	128	0,35	30°	3/4" X 7/16"	25	11,000
		650	2															11,100
LCG 140	08140000	650	1	140	20	60	30	65	191,51	54	86	130	145	0,40	30°	1" X 17 mm	21	18,000
		1200	2															18,100
LCG 170	08170000	1000	1	170	28	65	30	75	223,74	84	95	130	184	0,50	30°	1" X 17 mm	25	27,000
		1800	2															27,200





- Suitable to connect two shafts in axis
- With hardened sprockets
- Provided with full cover, seals and O-ring for the protection from external contamination and also for an eventual lubrication of the coupling with grease.

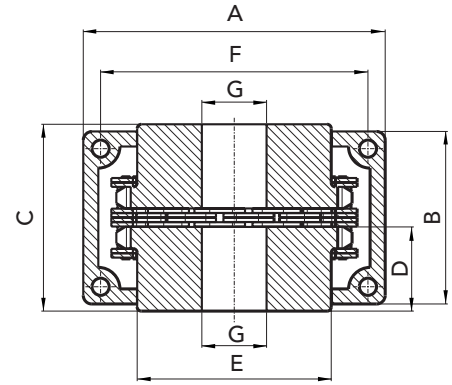
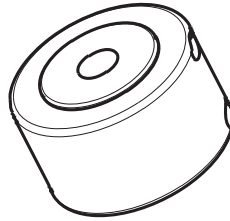

TYPE	PART NUMBER	CHAIN PITCH	A	B	C	D	E	G	G Max	Nm	Weight Kg.
KC 3012	KC3012	ASA 35-2	69	63	65	29,5	27,2	12	16	150	0,50
KC 4012	KC4012	ASA 40-2	77	72	79,4	36	36	12	22	210	1,00
KC 4014	KC4014	ASA 40-2	84	75	79,4	36	45	12	28	300	1,40
KC 4016	KC4016	ASA 40-2	92	72	87,4	40	54,5	13,5	32	380	1,80
KC 5014	KC5014	ASA 50-2	101	85	99,7	45	56	14,5	35	550	2,50
KC 5016	KC5016	ASA 50-2	110	87	99,7	45	64	14,5	40	725	3,20
KC 5018	KC5018	ASA 50-2	122	85	99,7	45	73,5	16	45	925	4,00
KC 6018	KC6018	ASA 60-2	147	105	123,5	56	89,5	20	55	1750	7,20
KC 6020	KC6020	ASA 60-2	158	105	123,5	56	102,5	20	60	2050	9,50
KC 6022	KC6022	ASA 60-2	168	117	123,5	56	115	20	75	2400	11,3
KC 8018	KC8018	ASA 80-2	190	129	141,2	63	115	20	75	3800	14,7
KC 8020	KC8020	ASA 80-2	210	137	145,2	65	125	20	80	4700	18,2
KC 8022	KC8022	ASA 80-2	226	137	157,2	71	142	20	90	5500	23,3
KC 10020	KC10020	ASA 100-2	281	153	178,8	80	162	25	110	8700	36,0
KC 12018	KC12018	ASA 120-2	307	181	202,7	90	173	35	120	13250	49,0
KC 12022	KC12022	ASA 120-2	357	181	222,7	100	213	35	150	17800	77,0

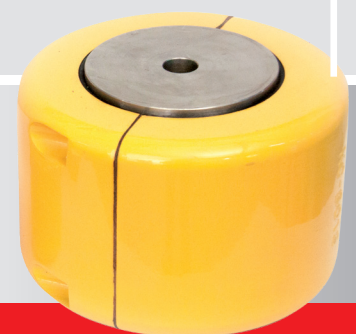

CAD drawings available on our site
www.chiaravalli.com

Quantity, availability and prices
 on B2B Chiaravalli

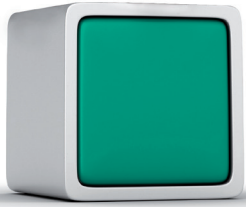

SPECIAL

COMPONENTS MANUFACTURING

We produce high precision Gears and Special Mechanical Components.

A large and varied range of modern CNC machine tools assures large capacity production at high quality level.

Chiaravalli Group SpA co-workers, highly skilful and motivated by a great spirit of belonging to the company,

operate using the most modern CAE and CAD-CAM technologies. The production is certified and assured using three-dimensional high precision measuring machines.

Chiaravalli Group SpA your technological partner for high quality production.



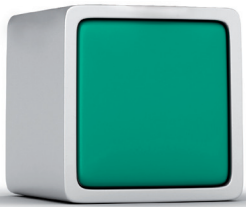

WORM SCREW

JACKS

The new line of Worm Screw Jacks named CHT (Chiaravalli High Tech) integrates and completes our range of Mechanical Transmission products.

This new line of products is manufactured using high quality materials, manufactured with absolute precision, making use of the modern machinery fleet of the companies belonging to Chiaravalli Group SpA.

The basic elements that make up the final product "Screw Jack" are made in large series, rigorously checked and put in stock.

Special virtual software developed by Chiaravalli Group SpA enables our customers to first view the various elements of the required screw jack and then, in the second phase, to order it with absolute precision and confidence.

Chiaravalli Group SpA is engaged to ensure the delivery of this product in very short time, with quality and precision.

