

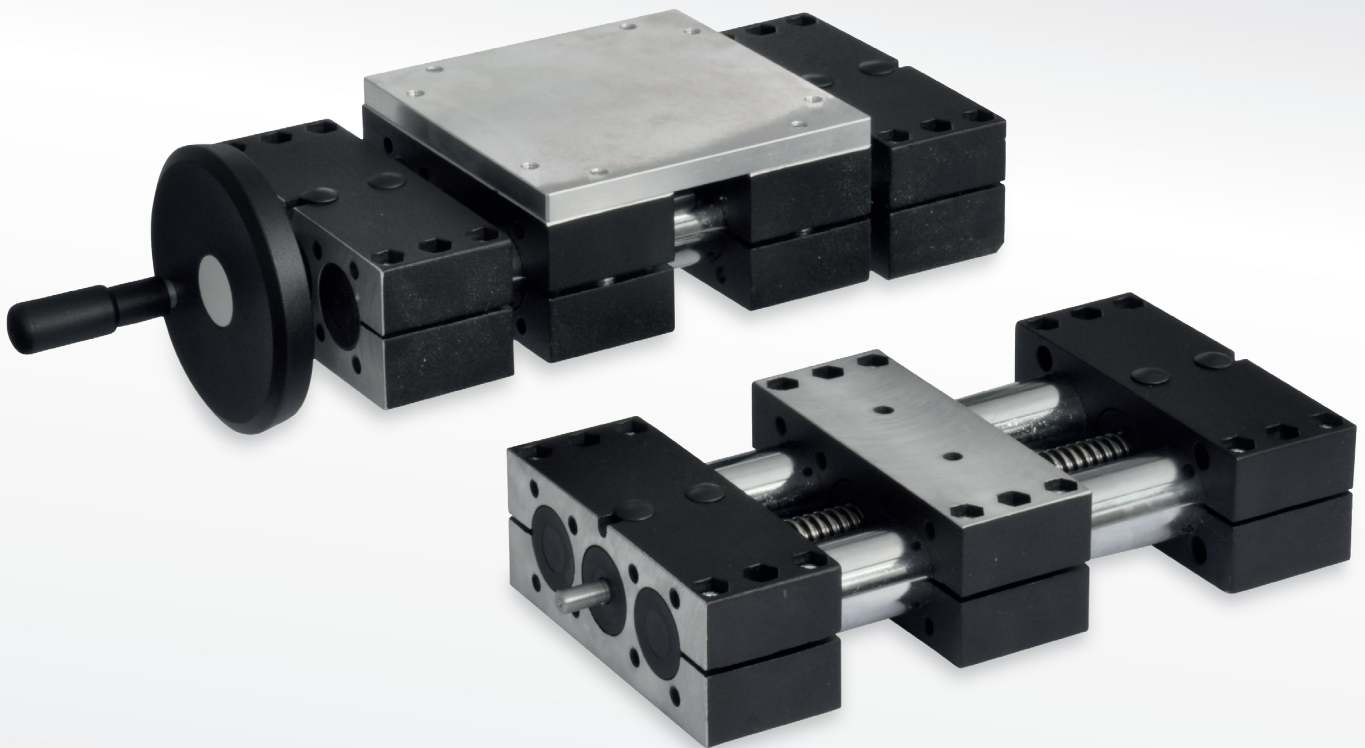

Double tube  
linear actuators





**Standard Machine Elements Worldwide**



# GN 491

## Double tube linear actuators



### Specification

#### Types

- Type **R1**: Right hand thread, single shaft end.
- Type **R2**: Right hand thread, two shaft ends.
- Type **L1**: Left hand thread, single shaft end.
- Type **L2**: Left hand thread, two shaft ends.

#### Identification no.

- Version **1**: short shaft end
- Version **2**: long shaft end (for position indicator)
- Version **3**: 1 x short shaft end / 1 x long shaft end (for position indicator)

Guide tubes DIN 2391  
Steel, chrome-plated **SCR**.

#### End pieces / Slider

Aluminium

- plastic coated  
black, RAL 9005, textured finish
- Fixing surface / mounting surface  
machined, blank

Spindle with trapezoidal thread

Steel, blank with ball-bearing

Positioning accuracy  $\pm 0.2$  mm / 300 mm travel

Follower nut, gun metal

Cylinder head screws DIN 912

Steel, zinc plated

Hexagon nuts DIN 985

Steel, zinc plated

### Information

In addition to the standard travel lengths specified in the above table for the double tube linear actuator GN 491 any length inside the maximum length is available.

In order to measure the movement and positioning of the sliders, digital position indicators can be added.

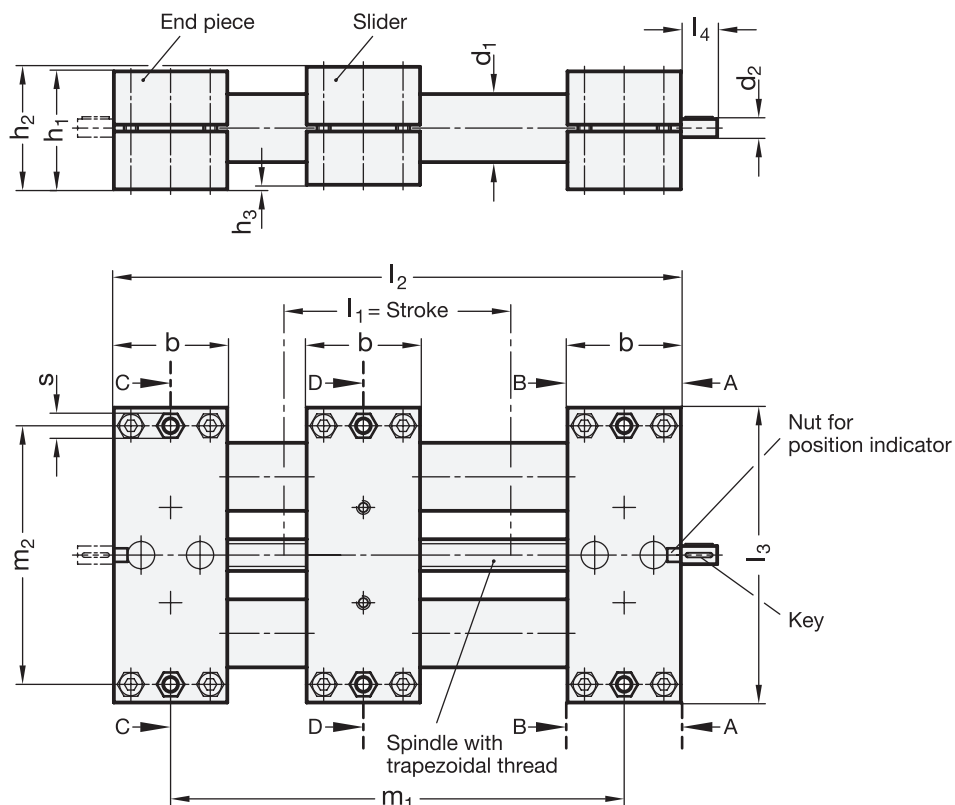
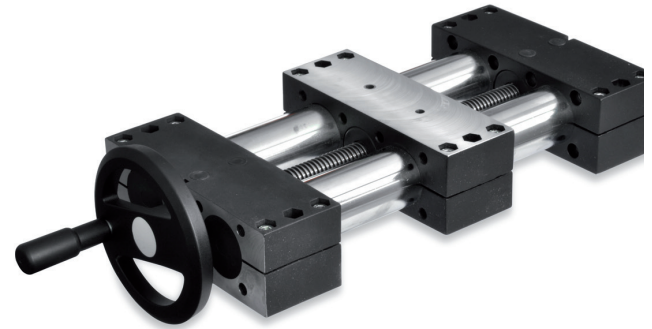

Standard Elements	Main dimensions														
Description	d1	l1 Stroke	l1 max. stroke	b	d2	h1	h2	h3	l2	l3	l4 short	l4 long	m1	m2	s
GN 491-30-100-R1-1-SCR	30	100	1500	50	8	52	54	2	3xb+l1	130	16	-	2xb+l1	114	10
GN 491-30-100-R1-2-SCR	30	100	1500	50	8	52	54	2	3xb+l1	130	-	49	2xb+l1	114	10
GN 491-30-150-R1-1-SCR	30	150	1500	50	8	52	54	2	3xb+l1	130	16	-	2xb+l1	114	10
GN 491-30-150-R1-2-SCR	30	150	1500	50	8	52	54	2	3xb+l1	130	-	49	2xb+l1	114	10
GN 491-30-200-R1-1-SCR	30	200	1500	50	8	52	54	2	3xb+l1	130	16	-	2xb+l1	114	10
GN 491-30-200-R1-2-SCR	30	200	1500	50	8	52	54	2	3xb+l1	130	-	49	2xb+l1	114	10
GN 491-30-300-R1-1-SCR	30	300	1500	50	8	52	54	2	3xb+l1	130	16	-	2xb+l1	114	10
GN 491-30-300-R1-2-SCR	30	300	1500	50	8	52	54	2	3xb+l1	130	-	49	2xb+l1	114	10
GN 491-50-100-R1-1-SCR	50	100	2675	72	12	72	76	4	3xb+l1	206	18	-	2xb+l1	184	13
GN 491-50-100-R1-2-SCR	50	100	2675	72	12	72	76	4	3xb+l1	206	-	55	2xb+l1	184	13
GN 491-50-150-R1-1-SCR	50	150	2675	72	12	72	76	4	3xb+l1	206	18	-	2xb+l1	184	13
GN 491-50-150-R1-2-SCR	50	150	2675	72	12	72	76	4	3xb+l1	206	-	55	2xb+l1	184	13
GN 491-50-200-R1-1-SCR	50	200	2675	72	12	72	76	4	3xb+l1	206	18	-	2xb+l1	184	13
GN 491-50-200-R1-2-SCR	50	200	2675	72	12	72	76	4	3xb+l1	206	-	55	2xb+l1	184	13
GN 491-50-300-R1-1-SCR	50	300	2675	72	12	72	76	4	3xb+l1	206	18	-	2xb+l1	184	13
GN 491-50-300-R1-2-SCR	50	300	2675	72	12	72	76	4	3xb+l1	206	-	55	2xb+l1	184	13
GN 491-30-100-L1-1-SCR*	30	100	1500	50	8	52	54	2	3xb+l1	130	16	-	2xb+l1	114	10
GN 491-30-100-L1-2-SCR*	30	100	1500	50	8	52	54	2	3xb+l1	130	-	49	2xb+l1	114	10
GN 491-30-150-L1-1-SCR*	30	150	1500	50	8	52	54	2	3xb+l1	130	16	-	2xb+l1	114	10
GN 491-30-150-L1-2-SCR*	30	150	1500	50	8	52	54	2	3xb+l1	130	-	49	2xb+l1	114	10
GN 491-30-200-L1-1-SCR*	30	200	1500	50	8	52	54	2	3xb+l1	130	16	-	2xb+l1	114	10
GN 491-30-200-L1-2-SCR*	30	200	1500	50	8	52	54	2	3xb+l1	130	-	49	2xb+l1	114	10
GN 491-30-300-L1-1-SCR*	30	300	1500	50	8	52	54	2	3xb+l1	130	16	-	2xb+l1	114	10
GN 491-30-300-L1-2-SCR*	30	300	1500	50	8	52	54	2	3xb+l1	130	-	49	2xb+l1	114	10
GN 491-50-100-L1-1-SCR*	50	100	2675	72	12	72	76	4	3xb+l1	206	18	-	2xb+l1	184	13
GN 491-50-100-L1-2-SCR*	50	100	2675	72	12	72	76	4	3xb+l1	206	-	55	2xb+l1	184	13
GN 491-50-150-L1-1-SCR*	50	150	2675	72	12	72	76	4	3xb+l1	206	18	-	2xb+l1	184	13
GN 491-50-150-L1-2-SCR*	50	150	2675	72	12	72	76	4	3xb+l1	206	-	55	2xb+l1	184	13
GN 491-50-200-L1-1-SCR*	50	200	2675	72	12	72	76	4	3xb+l1	206	18	-	2xb+l1	184	13
GN 491-50-200-L1-2-SCR*	50	200	2675	72	12	72	76	4	3xb+l1	206	-	55	2xb+l1	184	13
GN 491-50-300-L1-1-SCR*	50	300	2675	72	12	72	76	4	3xb+l1	206	18	-	2xb+l1	184	13
GN 491-50-300-L1-2-SCR*	50	300	2675	72	12	72	76	4	3xb+l1	206	-	55	2xb+l1	184	13
GN 491-30-100-R2-1-SCR*	30	100	1500	50	8	52	54	2	3xb+l1	130	16	-	2xb+l1	114	10
GN 491-30-100-R2-2-SCR*	30	100	1500	50	8	52	54	2	3xb+l1	130	-	49	2xb+l1	114	10
GN 491-30-100-R2-3-SCR*	30	100	1500	50	8	52	54	2	3xb+l1	130	16	49	2xb+l1	114	10
GN 491-30-150-R2-1-SCR*	30	150	1500	450	8	52	54	2	3xb+l1	130	16	-	2xb+l1	114	10
GN 491-30-150-R2-2-SCR*	30	150	1500	50	8	52	54	2	3xb+l1	130	-	49	2xb+l1	114	10
GN 491-30-150-R2-3-SCR*	30	150	1500	50	8	52	54	2	3xb+l1	130	16	49	2xb+l1	114	10
GN 491-30-200-R2-1-SCR*	30	200	1500	50	8	52	54	2	3xb+l1	130	16	-	2xb+l1	114	10
GN 491-30-200-R2-2-SCR*	30	200	1500	50	8	52	54	2	3xb+l1	130	-	49	2xb+l1	114	10
GN 491-30-200-R2-3-SCR*	30	200	1500	50	8	52	54	2	3xb+l1	130	16	-	2xb+l1	114	10

\* normally not available from stock

Standard Elements	Main dimensions														
Description	d1	l1 Stroke	l1 max. stroke	b	d2	h1	h2	h3	l2	l3	l4 short	l4 long	m1	m2	s
GN 491-30-300-R2-1-SCR*	30	300	1500	50	8	52	54	2	3xb+l1	130	16	-	2xb+l1	114	10
GN 491-30-300-R2-2-SCR*	30	300	1500	50	8	52	54	2	3xb+l1	130	-	49	2xb+l1	114	10
GN 491-30-300-R2-3-SCR*	30	300	1500	50	8	52	54	2	3xb+l1	130	16	49	2xb+l1	114	10
GN 491-50-100-R2-1-SCR*	50	100	2675	72	12	72	76	4	3xb+l1	130	18	-	2xb+l1	184	13
GN 491-50-100-R2-2-SCR*	50	100	2675	72	12	72	76	4	3xb+l1	206	-	55	2xb+l1	184	13
GN 491-50-100-R2-3-SCR*	50	100	2675	72	12	72	76	4	3xb+l1	206	18	55	2xb+l1	184	13
GN 491-50-150-R2-1-SCR*	50	150	2675	72	12	72	76	4	3xb+l1	206	18	-	2xb+l1	184	13
GN 491-50-150-R2-2-SCR*	50	150	2675	72	12	72	76	4	3xb+l1	206	-	55	2xb+l1	184	13
GN 491-50-150-R2-3-SCR*	50	150	2675	72	12	72	76	4	3xb+l1	206	18	55	2xb+l1	184	13
GN 491-50-200-R2-1-SCR*	50	200	2675	72	12	72	76	4	3xb+l1	206	18	-	2xb+l1	184	13
GN 491-50-200-R2-2-SCR*	50	200	2675	72	12	72	76	4	3xb+l1	206	-	55	2xb+l1	184	13
GN 491-50-200-R2-3-SCR*	50	200	2675	72	12	72	76	4	3xb+l1	206	18	55	2xb+l1	184	13
GN 491-50-300-R2-1-SCR*	50	300	2675	72	12	72	76	4	3xb+l1	206	18	-	2xb+l1	184	13
GN 491-50-300-R2-2-SCR*	50	300	2675	72	12	72	76	4	3xb+l1	206	-	55	2xb+l1	184	13
GN 491-50-300-R2-3-SCR*	50	300	2675	72	12	72	76	4	3xb+l1	206	18	55	2xb+l1	184	13
GN 491-30-100-L2-1-SCR*	30	100	1500	50	8	52	54	2	3xb+l1	130	16	-	2xb+l1	114	10
GN 491-30-100-L2-2-SCR*	30	100	1500	50	8	52	54	2	3xb+l1	130	-	49	2xb+l1	114	10
GN 491-30-100-L2-3-SCR*	30	100	1500	50	8	52	54	2	3xb+l1	130	16	49	2xb+l1	114	10
GN 491-30-150-L2-1-SCR*	30	150	1500	50	8	52	54	2	3xb+l1	130	16	-	2xb+l1	114	10
GN 491-30-150-L2-2-SCR*	30	150	1500	50	8	52	54	2	3xb+l1	130	-	49	2xb+l1	114	10
GN 491-30-150-L2-3-SCR*	30	150	1500	50	8	52	54	2	3xb+l1	130	16	49	2xb+l1	114	10
GN 491-30-200-L2-1-SCR*	30	200	1500	50	8	52	54	2	3xb+l1	130	16	-	2xb+l1	114	10
GN 491-30-200-L2-2-SCR*	30	200	1500	50	8	52	54	2	3xb+l1	130	-	49	2xb+l1	114	10
GN 491-30-200-L2-3-SCR*	30	200	1500	50	8	52	54	2	3xb+l1	130	16	49	2xb+l1	114	10
GN 491-30-300-L2-1-SCR*	30	300	1500	50	8	52	54	2	3xb+l1	130	16	-	2xb+l1	114	10
GN 491-30-300-L2-2-SCR*	30	300	1500	50	8	52	54	2	3xb+l1	130	-	49	2xb+l1	114	10
GN 491-30-300-L2-3-SCR*	30	300	1500	50	8	52	54	2	3xb+l1	130	16	49	2xb+l1	114	10
GN 491-50-100-L2-1-SCR*	50	100	2675	72	12	72	76	4	3xb+l1	206	18	-	2xb+l1	184	13
GN 491-50-100-L2-2-SCR*	50	100	2675	72	12	72	76	4	3xb+l1	206	-	55	2xb+l1	184	13
GN 491-50-100-L2-3-SCR*	50	100	2675	72	12	72	76	4	3xb+l1	206	18	55	2xb+l1	184	13
GN 491-50-150-L2-1-SCR*	50	150	2675	72	12	72	76	4	3xb+l1	206	18	-	2xb+l1	184	13
GN 491-50-150-L2-2-SCR*	50	150	2675	72	12	72	76	4	3xb+l1	206	-	55	2xb+l1	184	13
GN 491-50-150-L2-3-SCR*	50	150	2675	72	12	72	76	4	3xb+l1	206	18	55	2xb+l1	184	13
GN 491-50-200-L2-1-SCR*	50	200	2675	72	12	72	76	4	3xb+l1	206	18	-	2xb+l1	184	13
GN 491-50-200-L2-2-SCR*	50	200	2675	72	12	72	76	4	3xb+l1	206	-	55	2xb+l1	184	13
GN 491-50-200-L2-3-SCR*	50	200	2675	72	12	72	76	4	3xb+l1	206	18	55	2xb+l1	184	13
GN 491-50-300-L2-1-SCR*	50	300	2675	72	12	72	76	4	3xb+l1	206	18	-	2xb+l1	184	13
GN 491-50-300-L2-2-SCR*	50	300	2675	72	12	72	76	4	3xb+l1	206	-	55	2xb+l1	184	13
GN 491-50-300-L2-3-SCR*	50	300	2675	72	12	72	76	4	3xb+l1	206	18	55	2xb+l1	184	13

\* normally not available from stock

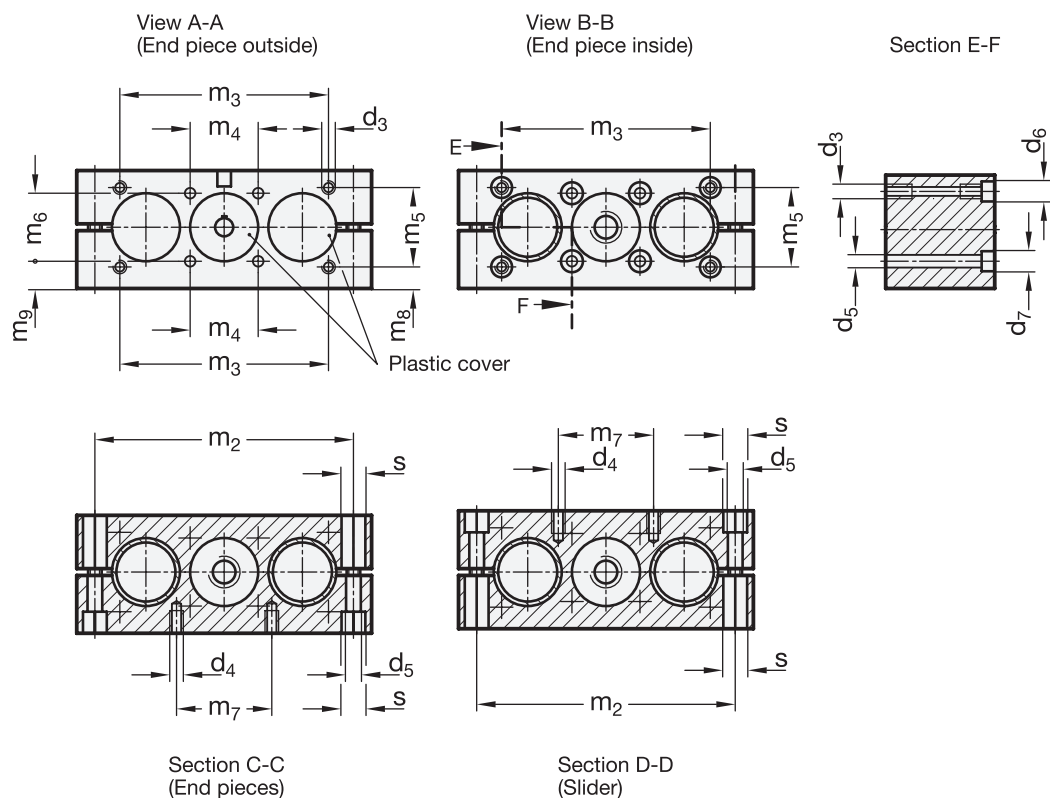

Standard Elements	Main dimensions															Shaft thread	Key DIN 6885	Position indicator	Hand-wheel	g	
	Description	d3**	d4***	d5	d6	#	d7	#	m2	m3	m4	m5	m6	m7	m8						m9
GN 491-30-100-R1-1-SCR	M 6	M 6	6.5	10	M 5	11	M 6	114	92	30	35	30	42	9.5	12	10	TR14x4	A2x2x12	DD51	GN 923.30	2980
GN 491-30-100-R1-2-SCR	M 6	M 6	6.5	10	M 5	11	M 6	114	92	30	35	30	42	9.5	12	10	TR14x4	A2x2x12	DD51	GN 923.30	2980
GN 491-30-150-R1-1-SCR	M 6	M 6	6.5	10	M 5	11	M 6	114	92	30	35	30	42	9.5	12	10	TR14x4	A2x2x12	DD51	GN 923.30	3000
GN 491-30-150-R1-2-SCR	M 6	M 6	6.5	10	M 5	11	M 6	114	92	30	35	30	42	9.5	12	10	TR14x4	A2x2x12	DD51	GN 923.30	3000
GN 491-30-200-R1-1-SCR	M 6	M 6	6.5	10	M 5	11	M 6	114	92	30	35	30	42	9.5	12	10	TR14x4	A2x2x12	DD51	GN 923.30	3160
GN 491-30-200-R1-2-SCR	M 6	M 6	6.5	10	M 5	11	M 6	114	92	30	35	30	42	9.5	12	10	TR14x4	A2x2x12	DD51	GN 923.30	3160
GN 491-30-300-R1-1-SCR	M 6	M 6	6.5	10	M 5	11	M 6	114	92	30	35	30	42	9.5	12	10	TR14x4	A2x2x12	DD51	GN 923.30	3520
GN 491-30-300-R1-2-SCR	M 6	M 6	6.5	10	M 5	11	M 6	114	92	30	35	30	42	9.5	12	10	TR14x4	A2x2x12	DD51	GN 923.30	3520
GN 491-50-100-R1-1-SCR	M 10	M 8	8.5	15	M 8	15	M 8	184	150	46	50	46	62	13	15	13	TR20x4	A4x4x12	DD52R	GN 924.50	8900
GN 491-50-100-R1-2-SCR	M 10	M 8	8.5	15	M 8	15	M 8	184	150	46	50	46	62	13	15	13	TR20x4	A4x4x12	DD52R	GN 924.50	8900
GN 491-50-150-R1-1-SCR	M 10	M 8	8.5	15	M 8	15	M 8	184	150	46	50	46	62	13	15	13	TR20x4	A4x4x12	DD52R	GN 924.50	9440
GN 491-50-150-R1-2-SCR	M 10	M 8	8.5	15	M 8	15	M 8	184	150	46	50	46	62	13	15	13	TR20x4	A4x4x12	DD52R	GN 924.50	9440
GN 491-50-200-R1-1-SCR	M 10	M 8	8.5	15	M 8	15	M 8	184	150	46	50	46	62	13	15	13	TR20x4	A4x4x12	DD52R	GN 924.50	10000
GN 491-50-200-R1-2-SCR	M 10	M 8	8.5	15	M 8	15	M 8	184	150	46	50	46	62	13	15	13	TR20x4	A4x4x12	DD52R	GN 924.50	10000
GN 491-50-300-R1-1-SCR	M 10	M 8	8.5	15	M 8	15	M 8	184	150	46	50	46	62	13	15	13	TR20x4	A4x4x12	DD52R	GN 924.50	11120
GN 491-50-300-R1-2-SCR	M 10	M 8	8.5	15	M 8	15	M 8	184	150	46	50	46	62	13	15	13	TR20x4	A4x4x12	DD52R	GN 924.50	11120
GN 491-30-100-L1-1-SCR*	M 6	M 6	6.5	10	M 5	11	M 6	114	92	30	35	30	42	9.5	12	10	TR14x4	A2x2x12	DD51	GN 923.30	2980
GN 491-30-100-L1-2-SCR*	M 6	M 6	6.5	10	M 5	11	M 6	114	92	30	35	30	42	9.5	12	10	TR14x4	A2x2x12	DD51	GN 923.30	2980
GN 491-30-150-L1-1-SCR*	M 6	M 6	6.5	10	M 5	11	M 6	114	92	30	35	30	42	9.5	12	10	TR14x4	A2x2x12	DD51	GN 923.30	3000
GN 491-30-150-L1-2-SCR*	M 6	M 6	6.5	10	M 5	11	M 6	114	92	30	35	30	42	9.5	12	10	TR14x4	A2x2x12	DD51	GN 923.30	3000
GN 491-30-200-L1-1-SCR*	M 6	M 6	6.5	10	M 5	11	M 6	114	92	30	35	30	42	9.5	12	10	TR14x4	A2x2x12	DD51	GN 923.30	3160
GN 491-30-200-L1-2-SCR*	M 6	M 6	6.5	10	M 5	11	M 6	114	92	30	35	30	42	9.5	12	10	TR14x4	A2x2x12	DD51	GN 923.30	3160
GN 491-30-300-L1-1-SCR*	M 6	M 6	6.5	10	M 5	11	M 6	114	92	30	35	30	42	9.5	12	10	TR14x4	A2x2x12	DD51	GN 923.30	3520
GN 491-30-300-L1-2-SCR*	M 6	M 6	6.5	10	M 5	11	M 6	114	92	30	35	30	42	9.5	12	10	TR14x4	A2x2x12	DD51	GN 923.30	3520

Standard Elements Description	Main dimensions																Shaft thread	Key DIN 6885	Position indi- cator	Hand- wheel	⚖ g
	d3**	d4***	d5	d6	#	d7	#	m2	m3	m4	m5	m6	m7	m8	m9	s					
GN 491-50-100-L1-1-SCR*	M 10	M 8	8.5	15	M 8	15	M 8	184	150	46	50	46	62	13	15	13	TR20x4	A4x4x12	DD52R	GN 924.50	8900
GN 491-50-100-L1-2-SCR*	M 10	M 8	8.5	15	M 8	15	M 8	184	150	46	50	46	62	13	15	13	TR20x4	A4x4x12	DD52R	GN 924.50	8900
GN 491-50-150-L1-1-SCR*	M 10	M 8	8.5	15	M 8	15	M 8	184	150	46	50	46	62	13	15	13	TR20x4	A4x4x12	DD52R	GN 924.50	9440
GN 491-50-150-L1-2-SCR*	M 10	M 8	8.5	15	M 8	15	M 8	184	150	46	50	46	62	13	15	13	TR20x4	A4x4x12	DD52R	GN 924.50	9440
GN 491-50-200-L1-1-SCR*	M 10	M 8	8.5	15	M 8	15	M 8	184	150	46	50	46	62	13	15	13	TR20x4	A4x4x12	DD52R	GN 924.50	10000
GN 491-50-200-L1-2-SCR*	M 10	M 8	8.5	15	M 8	15	M 8	184	150	46	50	46	62	13	15	13	TR20x4	A4x4x12	DD52R	GN 924.50	10000
GN 491-50-300-L1-1-SCR*	M 10	M 8	8.5	15	M 8	15	M 8	184	150	46	50	46	62	13	15	13	TR20x4	A4x4x12	DD52R	GN 924.50	11120
GN 491-50-300-L1-2-SCR*	M 10	M 8	8.5	15	M 8	15	M 8	184	150	46	50	46	62	13	15	13	TR20x4	A4x4x12	DD52R	GN 924.50	11120
GN 491-30-100-R2-1-SCR*	M 6	M 6	6.5	10	M 5	11	M 6	114	92	30	35	30	42	9.5	12	10	TR14x4	A2x2x12	DD51	GN 923.30	2980
GN 491-30-100-R2-2-SCR*	M 6	M 6	6.5	10	M 5	11	M 6	114	92	30	35	30	42	9.5	12	10	TR14x4	A2x2x12	DD51	GN 923.30	2980
GN 491-30-100-R2-3-SCR*	M 6	M 6	6.5	10	M 5	11	M 6	114	92	30	35	30	42	9.5	12	10	TR14x4	A2x2x12	DD51	GN 923.30	2980
GN 491-30-150-R2-1-SCR*	M 6	M 6	6.5	10	M 5	11	M 6	114	92	30	35	30	42	9.5	12	10	TR14x4	A2x2x12	DD51	GN 923.30	3000
GN 491-30-150-R2-2-SCR*	M 6	M 6	6.5	10	M 5	11	M 6	114	92	30	35	30	42	9.5	12	10	TR14x4	A2x2x12	DD51	GN 923.30	3000
GN 491-30-150-R2-3-SCR*	M 6	M 6	6.5	10	M 5	11	M 6	114	92	30	35	30	42	9.5	12	10	TR14x4	A2x2x12	DD51	GN 923.30	3000
GN 491-30-200-R2-1-SCR*	M 6	M 6	6.5	10	M 5	11	M 6	114	92	30	35	30	42	9.5	12	10	TR14x4	A2x2x12	DD51	GN 923.30	3160
GN 491-30-200-R2-2-SCR*	M 6	M 6	6.5	10	M 5	11	M 6	114	92	30	35	30	42	9.5	12	10	TR14x4	A2x2x12	DD51	GN 923.30	3160
GN 491-30-200-R2-3-SCR*	M 6	M 6	6.5	10	M 5	11	M 6	114	92	30	35	30	42	9.5	12	10	TR14x4	A2x2x12	DD51	GN 923.30	3160
GN 491-30-300-R2-1-SCR*	M 6	M 6	6.5	10	M 5	11	M 6	114	92	30	35	30	42	9.5	12	10	TR14x4	A2x2x12	DD51	GN 923.30	3520
GN 491-30-300-R2-2-SCR*	M 6	M 6	6.5	10	M 5	11	M 6	114	92	30	35	30	42	9.5	12	10	TR14x4	A2x2x12	DD51	GN 923.30	3520
GN 491-30-300-R2-3-SCR*	M 6	M 6	6.5	10	M 5	11	M 6	114	92	30	35	30	42	9.5	12	10	TR14x4	A2x2x12	DD51	GN 923.30	3520
GN 491-50-100-R2-1-SCR*	M 10	M 8	8.5	15	M 8	15	M 8	184	150	46	50	46	62	13	15	13	TR20x4	A4x4x12	DD52R	GN 924.50	8900
GN 491-50-100-R2-2-SCR*	M 10	M 8	8.5	15	M 8	15	M 8	184	150	46	50	46	62	13	15	13	TR20x4	A4x4x12	DD52R	GN 924.50	8900
GN 491-50-100-R2-3-SCR*	M 10	M 8	8.5	15	M 8	15	M 8	184	150	46	50	46	62	13	15	13	TR20x4	A4x4x12	DD52R	GN 924.50	8900
GN 491-50-150-R2-1-SCR*	M 10	M 8	8.5	15	M 8	15	M 8	184	150	46	50	46	62	13	15	13	TR20x4	A4x4x12	DD52R	GN 924.50	9440
GN 491-50-150-R2-2-SCR*	M 10	M 8	8.5	15	M 8	15	M 8	184	150	46	50	46	62	13	15	13	TR20x4	A4x4x12	DD52R	GN 924.50	9440
GN 491-50-150-R2-3-SCR*	M 10	M 8	8.5	15	M 8	15	M 8	184	150	46	50	46	62	13	15	13	TR20x4	A4x4x12	DD52R	GN 924.50	9440
GN 491-50-200-R2-1-SCR*	M 10	M 8	8.5	15	M 8	15	M 8	184	150	46	50	46	62	13	15	13	TR20x4	A4x4x12	DD52R	GN 924.50	10000
GN 491-50-200-R2-2-SCR*	M 10	M 8	8.5	15	M 8	15	M 8	184	150	46	50	46	62	13	15	13	TR20x4	A4x4x12	DD52R	GN 924.50	10000
GN 491-50-200-R2-3-SCR*	M 10	M 8	8.5	15	M 8	15	M 8	184	150	46	50	46	62	13	15	13	TR20x4	A4x4x12	DD52R	GN 924.50	10000
GN 491-50-300-R2-1-SCR*	M 10	M 8	8.5	15	M 8	15	M 8	184	150	46	50	46	62	13	15	13	TR20x4	A4x4x12	DD52R	GN 924.50	11120
GN 491-50-300-R2-2-SCR*	M 10	M 8	8.5	15	M 8	15	M 8	184	150	46	50	46	62	13	15	13	TR20x4	A4x4x12	DD52R	GN 924.50	11120
GN 491-50-300-R2-3-SCR*	M 10	M 8	8.5	15	M 8	15	M 8	184	150	46	50	46	62	13	15	13	TR20x4	A4x4x12	DD52R	GN 924.50	11120
GN 491-30-100-L2-1-SCR*	M 6	M 6	6.5	10	M 5	11	M 6	114	92	30	35	30	42	9.5	12	10	TR14x4	A2x2x12	DD51	GN 923.30	2980
GN 491-30-100-L2-2-SCR*	M 6	M 6	6.5	10	M 5	11	M 6	114	92	30	35	30	42	9.5	12	10	TR14x4	A4x4x12	DD51	GN 923.30	2980
GN 491-30-100-L2-3-SCR*	M 6	M 6	6.5	10	M 5	11	M 6	114	92	30	35	30	42	9.5	12	10	TR14x4	A4x4x12	DD51	GN 923.30	2980
GN 491-30-150-L2-1-SCR*	M 6	M 6	6.5	10	M 5	11	M 6	114	92	30	35	30	42	9.5	12	10	TR14x4	A2x2x12	DD51	GN 923.30	3000
GN 491-30-150-L2-2-SCR*	M 6	M 6	6.5	10	M 5	11	M 6	114	92	30	35	30	42	9.5	12	10	TR14x4	A2x2x12	DD51	GN 923.30	3000
GN 491-30-150-L2-3-SCR*	M 6	M 6	6.5	10	M 5	11	M 6	114	92	30	35	30	42	9.5	12	10	TR14x4	A2x2x12	DD51	GN 923.30	3000
GN 491-30-200-L2-1-SCR*	M 6	M 6	6.5	10	M 5	11	M 6	114	92	30	35	30	42	9.5	12	10	TR14x4	A2x2x12	DD51	GN 923.30	3160
GN 491-30-200-L2-2-SCR*	M 6	M 6	6.5	10	M 5	11	M 6	114	92	30	35	30	42	9.5	12	10	TR14x4	A2x2x12	DD51	GN 923.30	3160
GN 491-30-200-L2-3-SCR*	M 6	M 6	6.5	10	M 5	11	M 6	114	92	30	35	30	42	9.5	12	10	TR14x4	A2x2x12	DD51	GN 923.30	3160
GN 491-30-300-L2-1-SCR*	M 6	M 6	6.5	10	M 5	11	M 6	114	92	30	35	30	42	9.5	12	10	TR14x4	A2x2x12	DD51	GN 923.30	3520
GN 491-30-300-L2-2-SCR*	M 6	M 6	6.5	10	M 5	11	M 6	114	92	30	35	30	42	9.5	12	10	TR14x4	A2x2x12	DD51	GN 923.30	3520
GN 491-30-300-L2-3-SCR*	M 6	M 6	6.5	10	M 5	11	M 6	114	92	30	35	30	42	9.5	12	10	TR14x4	A2x2x12	DD51	GN 923.30	3520



Standard Elements Description	Main dimensions																Shaft thread	Key DIN 6885	Position indi- cator	Hand- wheel	g
	d3**	d4***	d5	d6	#	d7	#	m2	m3	m4	m5	m6	m7	m8	m9	s					
GN 491-50-100-L2-1-SCR*	M 10	M 8	8.5	15	M 8	15	M 8	184	150	46	50	46	62	13	15	13	TR20x4	A4x4x12	DD52R	GN 924.50	8900
GN 491-50-100-L2-2-SCR*	M 10	M 8	8.5	15	M 8	15	M 8	184	150	46	50	46	62	13	15	13	TR20x4	A4x4x12	DD52R	GN 924.50	8900
GN 491-50-100-L2-3-SCR*	M 10	M 8	8.5	15	M 8	15	M 8	184	150	46	50	46	62	13	15	13	TR20x4	A4x4x12	DD52R	GN 924.50	8900
GN 491-50-150-L2-1-SCR*	M 10	M 8	8.5	15	M 8	15	M 8	184	150	46	50	46	62	13	15	13	TR20x4	A4x4x12	DD52R	GN 924.50	9440
GN 491-50-150-L2-2-SCR*	M 10	M 8	8.5	15	M 8	15	M 8	184	150	46	50	46	62	13	15	13	TR20x4	A4x4x12	DD52R	GN 924.50	9440
GN 491-50-150-L2-3-SCR*	M 10	M 8	8.5	15	M 8	15	M 8	184	150	46	50	46	62	13	15	13	TR20x4	A4x4x12	DD52R	GN 924.50	9440
GN 491-50-200-L2-1-SCR*	M 10	M 8	8.5	15	M 8	15	M 8	184	150	46	50	46	62	13	15	13	TR20x4	A4x4x12	DD52R	GN 924.50	10000
GN 491-50-200-L2-2-SCR*	M 10	M 8	8.5	15	M 8	15	M 8	184	150	46	50	46	62	13	15	13	TR20x4	A4x4x12	DD52R	GN 924.50	10000
GN 491-50-200-L2-3-SCR*	M 10	M 8	8.5	15	M 8	15	M 8	184	150	46	50	46	62	13	15	13	TR20x4	A4x4x12	DD52R	GN 924.50	10000
GN 491-50-300-L2-1-SCR*	M 10	M 8	8.5	15	M 8	15	M 8	184	150	46	50	46	62	13	15	13	TR20x4	A4x4x12	DD52R	GN 924.50	11120
GN 491-50-300-L2-2-SCR*	M 10	M 8	8.5	15	M 8	15	M 8	184	150	46	50	46	62	13	15	13	TR20x4	A4x4x12	DD52R	GN 924.50	11120
GN 491-50-300-L2-3-SCR*	M 10	M 8	8.5	15	M 8	15	M 8	184	150	46	50	46	62	13	15	13	TR20x4	A4x4x12	DD52R	GN 924.50	11120

\* normally not available from stock  
 \*\* useable depth of thread min. 2 x d3  
 \*\*\* useable depth of thread min. 1.5 x d4  
 # for screw DIN 912

### Mounting facilities of the end pieces

#### Horizontal

with screws for thread d4 or bore d5

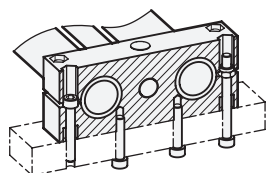

#### Vertical

from outside with screws for thread d3  
 from inside with screws for bore d6  
 from inside with screws for bore d5 / d7

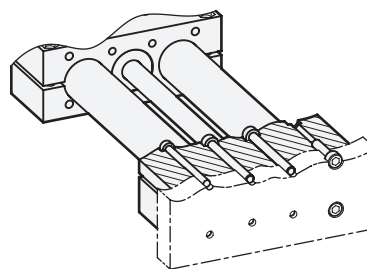

### Mounting facilities at the slider

Mounting with screws for thread d4 or bore d5

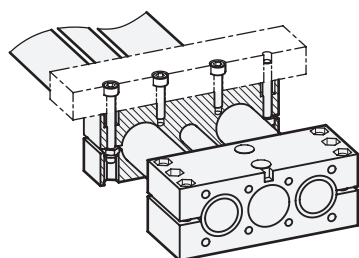

# GN 492

## Double tube linear actuators



### Specification

#### Types

- Type **R1**: Right hand thread, single shaft end.
- Type **R2**: Right hand thread, two shaft ends.
- Type **L1**: Left hand thread, single shaft end.
- Type **L2**: Left hand thread, two shaft ends.

#### Identification no.

- Version **1**: short shaft end
- Version **2**: long shaft end (for position indicator)
- Version **3**: 1 x short shaft end / 1 x long shaft end (for position indicator)

Guide tubes DIN 2391  
Steel, chrome-plated **SCR**.

#### End pieces / Slider

Aluminium

- plastic coated  
black, RAL 9005, textured finish
- Fixing surface / mounting surface  
machined, blank

Spindle with trapezoidal thread

Steel, blank with ball-bearing

Positioning accuracy  $\pm 0.2$  mm / 300 mm travel

Follower nut, gun metal

Cylinder head screws DIN 912

Steel, zinc plated

Hexagon nuts DIN 985

Steel, zinc plated

### Information

In addition to the standard travel lengths specified in the above table for the double tube linear actuator GN 492 any length inside the maximum length is available.

In order to measure the movement and positioning of the sliders, digital position indicators can be added.

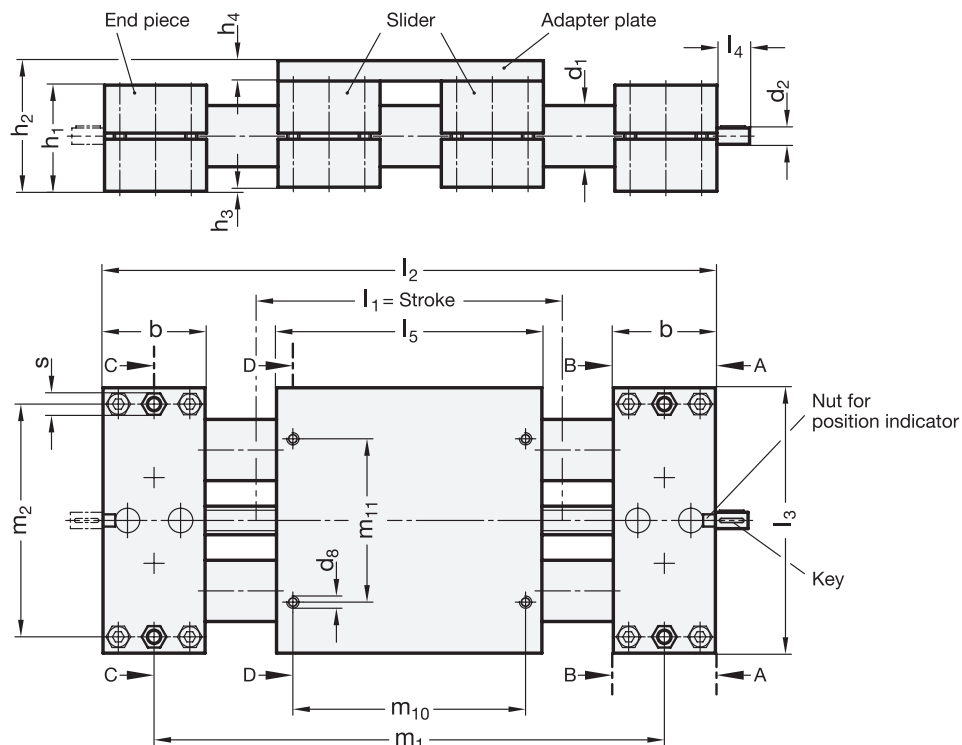
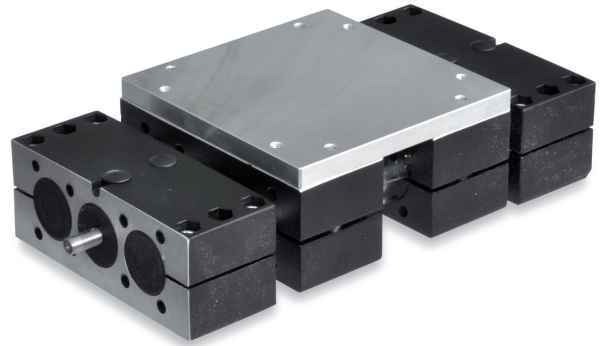

Standard Elements	Main dimensions																			
Description	d1	l1 Stroke	l1 max. stroke	b	d2	d8	h1	h2	h3	h4	l2	l3	l4 short	l4 long	l5	m1	m2	m10	m11	s
GN 492-30-100-R1-1-SCR	30	100	1500	50	8	M 6	52	64	2	10	2xb+l5+l1	130	16	-	130	b+l5+l1	114	114	80	10
GN 492-30-100-R1-2-SCR	30	100	1500	50	8	M 6	52	64	2	10	2xb+l5+l1	130	-	49	130	b+l5+l1	114	114	80	10
GN 492-30-150-R1-1-SCR	30	150	1500	50	8	M 6	52	64	2	10	2xb+l5+l1	130	16	-	130	b+l5+l1	114	114	80	10
GN 492-30-150-R1-2-SCR	30	150	1500	50	8	M 6	52	64	2	10	2xb+l5+l1	130	-	49	130	b+l5+l1	114	114	80	10
GN 492-30-200-R1-1-SCR	30	200	1500	50	8	M 6	52	64	2	10	2xb+l5+l1	130	16	-	130	b+l5+l1	114	114	80	10
GN 492-30-200-R1-2-SCR	30	200	1500	50	8	M 6	52	64	2	10	2xb+l5+l1	130	-	49	130	b+l5+l1	114	114	80	10
GN 492-30-300-R1-1-SCR	30	300	1500	50	8	M 6	52	64	2	10	2xb+l5+l1	130	16	-	130	b+l5+l1	114	114	80	10
GN 492-30-300-R1-2-SCR	30	300	1500	50	8	M 6	52	64	2	10	2xb+l5+l1	130	-	49	130	b+l5+l1	114	114	80	10
GN 492-50-100-R1-1-SCR	50	100	2540	72	12	M 8	72	92	4	16	2xb+l5+l1	206	18	-	206	b+l5+l1	184	184	134	13
GN 492-50-100-R1-2-SCR	50	100	2540	72	12	M 8	72	92	4	16	2xb+l5+l1	206	-	55	206	b+l5+l1	184	184	134	13
GN 492-50-150-R1-1-SCR	50	150	2540	72	12	M 8	72	92	4	16	2xb+l5+l1	206	18	-	206	b+l5+l1	184	184	134	13
GN 492-50-150-R1-2-SCR	50	150	2540	72	12	M 8	72	92	4	16	2xb+l5+l1	206	-	55	206	b+l5+l1	184	184	134	13
GN 492-50-200-R1-1-SCR	50	200	2540	72	12	M 8	72	92	4	16	2xb+l5+l1	206	18	-	206	b+l5+l1	184	184	134	13
GN 492-50-200-R1-2-SCR	50	200	2540	72	12	M 8	72	92	4	16	2xb+l5+l1	206	-	55	206	b+l5+l1	184	184	134	13
GN 492-50-300-R1-1-SCR	50	300	2540	72	12	M 8	72	92	4	16	2xb+l5+l1	206	18	-	206	b+l5+l1	184	184	134	13
GN 492-50-300-R1-2-SCR	50	300	2540	72	12	M 8	72	92	4	16	2xb+l5+l1	206	-	55	206	b+l5+l1	184	184	134	13
GN 492-30-100-L1-1-SCR*	30	100	1500	50	8	M 6	52	64	2	10	2xb+l5+l1	130	16	-	130	b+l5+l1	114	114	80	10
GN 492-30-100-L1-2-SCR*	30	100	1500	50	8	M 6	52	64	2	10	2xb+l5+l1	130	-	49	130	b+l5+l1	114	114	80	10
GN 492-30-150-L1-1-SCR*	30	150	1500	50	8	M 6	52	64	2	10	2xb+l5+l1	130	16	-	130	b+l5+l1	114	114	80	10
GN 492-30-150-L1-2-SCR*	30	150	1500	50	8	M 6	52	64	2	10	2xb+l5+l1	130	-	49	130	b+l5+l1	114	184	134	10
GN 492-30-200-L1-1-SCR*	30	200	1500	50	8	M 6	52	64	2	10	2xb+l5+l1	130	16	-	130	b+l5+l1	114	114	80	10
GN 492-30-200-L1-2-SCR*	30	200	1500	50	8	M 6	52	64	2	10	2xb+l5+l1	130	-	49	130	b+l5+l1	114	114	80	10
GN 492-30-300-L1-1-SCR*	30	300	1500	50	8	M 6	52	64	2	10	2xb+l5+l1	130	16	-	130	b+l5+l1	114	114	80	10
GN 492-30-300-L1-2-SCR*	30	300	1500	50	8	M 6	52	64	2	10	2xb+l5+l1	130	-	49	130	b+l5+l1	114	114	80	10
GN 492-50-100-L1-1-SCR*	50	100	2540	72	12	M 8	72	92	4	16	2xb+l5+l1	206	18	-	206	b+l5+l1	184	184	134	13
GN 492-50-100-L1-2-SCR*	50	100	2540	72	12	M 8	72	92	4	16	2xb+l5+l1	206	-	55	206	b+l5+l1	184	184	134	13
GN 492-50-150-L1-1-SCR*	50	150	2540	72	12	M 8	72	92	4	16	2xb+l5+l1	206	18	-	206	b+l5+l1	184	184	134	13
GN 492-50-150-L1-2-SCR*	50	150	2540	72	12	M 8	72	92	4	16	2xb+l5+l1	206	-	55	206	b+l5+l1	184	114	80	13
GN 492-50-200-L1-1-SCR*	50	200	2540	72	12	M 8	72	92	4	16	2xb+l5+l1	206	18	-	206	b+l5+l1	184	184	134	13
GN 492-50-200-L1-2-SCR*	50	200	2540	72	12	M 8	72	92	4	16	2xb+l5+l1	206	-	55	206	b+l5+l1	184	184	134	13
GN 492-50-300-L1-1-SCR*	50	300	2540	72	12	M 8	72	92	4	16	2xb+l5+l1	206	18	-	206	b+l5+l1	184	184	134	13
GN 492-50-300-L1-2-SCR*	50	300	2540	72	12	M 8	72	92	4	16	2xb+l5+l1	206	-	55	206	b+l5+l1	184	184	134	13
GN 492-30-100-R2-1-SCR*	30	100	1500	50	8	M 6	52	64	2	10	2xb+l5+l1	130	16	-	130	b+l5+l1	114	114	80	10
GN 492-30-100-R2-2-SCR*	30	100	1500	50	8	M 6	52	64	2	10	2xb+l5+l1	130	-	49	130	b+l5+l1	114	114	80	10
GN 492-30-100-R2-3-SCR*	30	100	1500	50	8	M 6	52	64	2	10	2xb+l5+l1	130	16	49	130	b+l5+l1	114	114	80	10
GN 492-30-150-R2-1-SCR*	30	150	1500	50	8	M 6	52	64	2	10	2xb+l5+l1	130	16	-	130	b+l5+l1	114	114	80	10
GN 492-30-150-R2-2-SCR*	30	150	1500	50	8	M 6	52	64	2	10	2xb+l5+l1	130	-	49	130	b+l5+l1	114	114	80	10
GN 492-30-100-R2-3-SCR*	30	150	1500	50	8	M 6	52	64	2	10	2xb+l5+l1	130	16	49	130	b+l5+l1	114	114	80	10
GN 492-30-200-R2-1-SCR*	30	200	1500	50	8	M 6	52	64	2	10	2xb+l5+l1	130	16	-	130	b+l5+l1	114	114	80	10
GN 492-30-200-R2-2-SCR*	30	200	1500	50	8	M 6	52	64	2	10	2xb+l5+l1	130	-	49	130	b+l5+l1	114	114	80	10
GN 492-30-200-R2-3-SCR*	30	200	1500	50	8	M 6	52	64	2	10	2xb+l5+l1	130	16	49	130	b+l5+l1	114	114	80	10

\* normally not available from stock

Standard Elements	Main dimensions																			
Description	d1	l1 Stroke	l1 max. stroke	b	d2	d8	h1	h2	h3	h4	l2	l3	l4 short	l4 long	l5	m1	m2	m10	m11	s
GN 492-30-300-R2-1-SCR*	30	300	1500	50	8	M 6	52	64	2	10	2xb+l5+l1	130	16	-	130	b+l5+l1	114	114	80	10
GN 492-30-300-R2-2-SCR*	30	300	1500	50	8	M 6	52	64	2	10	2xb+l5+l1	130	-	49	130	b+l5+l1	114	114	80	10
GN 492-30-300-R2-3-SCR*	30	300	1500	50	8	M 6	52	64	2	10	2xb+l5+l1	130	16	49	130	b+l5+l1	114	114	80	10
GN 492-50-100-R2-1-SCR*	50	100	2540	72	12	M 8	72	92	4	16	2xb+l5+l1	130	18	-	206	b+l5+l1	184	184	134	13
GN 492-50-100-R2-2-SCR*	50	100	2540	72	12	M 8	72	92	4	16	2xb+l5+l1	206	-	55	206	b+l5+l1	184	184	134	13
GN 492-50-100-R2-3-SCR*	50	100	2540	72	12	M 8	72	92	4	16	2xb+l5+l1	206	18	-	206	b+l5+l1	184	184	134	13
GN 492-50-150-R2-1-SCR*	50	150	2540	72	12	M 8	72	76	4	16	2xb+l5+l1	206	18	-	206	b+l5+l1	184	184	134	13
GN 492-50-150-R2-2-SCR*	50	150	2540	72	12	M 8	72	76	4	16	2xb+l5+l1	206	-	55	206	b+l5+l1	184	184	134	13
GN 492-50-150-R2-3-SCR*	50	150	2540	72	12	M 8	72	76	4	16	2xb+l5+l1	206	18	-	206	b+l5+l1	184	184	134	13
GN 492-50-200-R2-1-SCR*	50	200	2540	72	12	M 8	72	76	4	16	2xb+l5+l1	206	18	-	206	b+l5+l1	184	184	134	13
GN 492-50-200-R2-2-SCR*	50	200	2675	72	12	M 8	72	76	4	16	2xb+l5+l1	206	-	55	206	b+l5+l1	184	184	134	13
GN 492-50-200-R2-3-SCR*	50	200	2540	72	12	M 8	72	76	4	16	2xb+l5+l1	206	18	-	206	b+l5+l1	184	184	134	13
GN 492-50-300-R2-1-SCR*	50	300	2540	72	12	M 8	72	76	4	16	2xb+l5+l1	206	18	-	206	b+l5+l1	184	184	134	13
GN 492-50-300-R2-2-SCR*	50	300	2540	72	12	M 8	72	76	4	16	2xb+l5+l1	206	-	55	206	b+l5+l1	184	184	134	13
GN 492-50-300-R2-3-SCR*	50	300	2540	72	12	M 8	72	76	4	16	2xb+l5+l1	206	18	-	206	b+l5+l1	184	184	134	13
GN 492-30-100-L2-1-SCR*	30	100	1500	50	8	M 6	52	54	2	16	2xb+l5+l1	130	16	-	130	b+l5+l1	114	114	80	10
GN 492-30-100-L2-2-SCR*	30	100	1500	50	8	M 6	52	54	2	16	2xb+l5+l1	130	-	49	130	b+l5+l1	114	114	80	10
GN 492-30-100-L2-3-SCR*	30	100	1500	50	8	M 6	52	54	2	16	2xb+l5+l1	130	16	-	130	b+l5+l1	114	114	80	10
GN 492-30-150-L2-1-SCR*	30	150	1500	50	8	M 6	52	64	2	10	2xb+l5+l1	130	16	-	130	b+l5+l1	114	114	80	10
GN 492-30-150-L2-2-SCR*	30	150	1500	50	8	M 6	52	64	2	10	2xb+l5+l1	130	-	49	130	b+l5+l1	114	114	80	10
GN 492-30-150-L2-3-SCR*	30	200	1500	50	8	M 6	52	64	2	10	2xb+l5+l1	130	16	-	130	b+l5+l1	114	114	80	10
GN 492-30-200-L2-1-SCR*	30	200	1500	50	8	M 6	52	64	2	10	2xb+l5+l1	130	16	-	130	b+l5+l1	114	114	80	10
GN 492-30-200-L2-2-SCR*	30	200	1500	50	8	M 6	52	64	2	10	2xb+l5+l1	130	-	49	130	b+l5+l1	114	114	80	10
GN 492-30-200-L2-3-SCR*	30	200	1500	50	8	M 6	52	64	2	10	2xb+l5+l1	130	16	-	130	b+l5+l1	114	114	80	10
GN 492-30-300-L2-1-SCR*	30	300	1500	50	8	M 6	52	64	2	10	2xb+l5+l1	130	16	-	130	b+l5+l1	114	114	80	10
GN 492-30-300-L2-2-SCR*	30	300	1500	50	8	M 6	52	64	2	10	2xb+l5+l1	130	-	49	130	b+l5+l1	114	114	80	10
GN 492-30-300-L2-3-SCR*	30	300	1500	50	8	M 6	52	64	2	10	2xb+l5+l1	130	16	-	130	b+l5+l1	114	114	80	10
GN 492-50-100-L2-1-SCR*	50	100	2540	72	12	M 8	72	92	4	16	2xb+l5+l1	206	18	-	206	b+l5+l1	184	184	134	13
GN 492-50-100-L2-2-SCR*	50	100	2540	72	12	M 8	72	92	4	16	2xb+l5+l1	206	-	55	206	b+l5+l1	184	184	134	13
GN 492-50-100-L2-3-SCR*	50	100	2540	72	12	M 8	72	92	4	16	2xb+l5+l1	206	18	-	206	b+l5+l1	184	184	134	13
GN 492-50-150-L2-1-SCR*	50	150	2540	72	12	M 8	72	92	4	16	2xb+l5+l1	206	18	-	206	b+l5+l1	184	184	134	13
GN 492-50-150-L2-2-SCR*	50	150	2540	72	12	M 8	72	92	4	16	2xb+l5+l1	206	-	55	206	b+l5+l1	184	184	134	13
GN 492-50-150-L2-3-SCR*	50	150	2540	72	12	M 8	72	92	4	16	2xb+l5+l1	206	18	-	206	b+l5+l1	184	184	134	13
GN 492-50-200-L2-1-SCR*	50	200	2540	72	12	M 8	72	92	4	16	2xb+l5+l1	206	18	-	206	b+l5+l1	184	184	134	13
GN 492-50-200-L2-2-SCR*	50	200	2540	72	12	M 8	72	92	4	16	2xb+l5+l1	206	-	55	206	b+l5+l1	184	184	134	13
GN 492-50-200-L2-3-SCR*	50	200	2540	72	12	M 8	72	92	4	16	2xb+l5+l1	206	18	-	206	b+l5+l1	184	184	134	13
GN 492-50-300-L2-1-SCR*	50	300	2540	72	12	M 8	72	92	4	16	2xb+l5+l1	206	18	-	206	b+l5+l1	184	184	134	13
GN 492-50-300-L2-2-SCR*	50	300	2540	72	12	M 8	72	92	4	16	2xb+l5+l1	206	-	55	206	b+l5+l1	184	184	134	13
GN 492-50-300-L2-3-SCR*	50	300	2540	72	12	M 8	72	92	4	16	2xb+l5+l1	206	18	-	206	b+l5+l1	184	184	134	13

\* normally not available

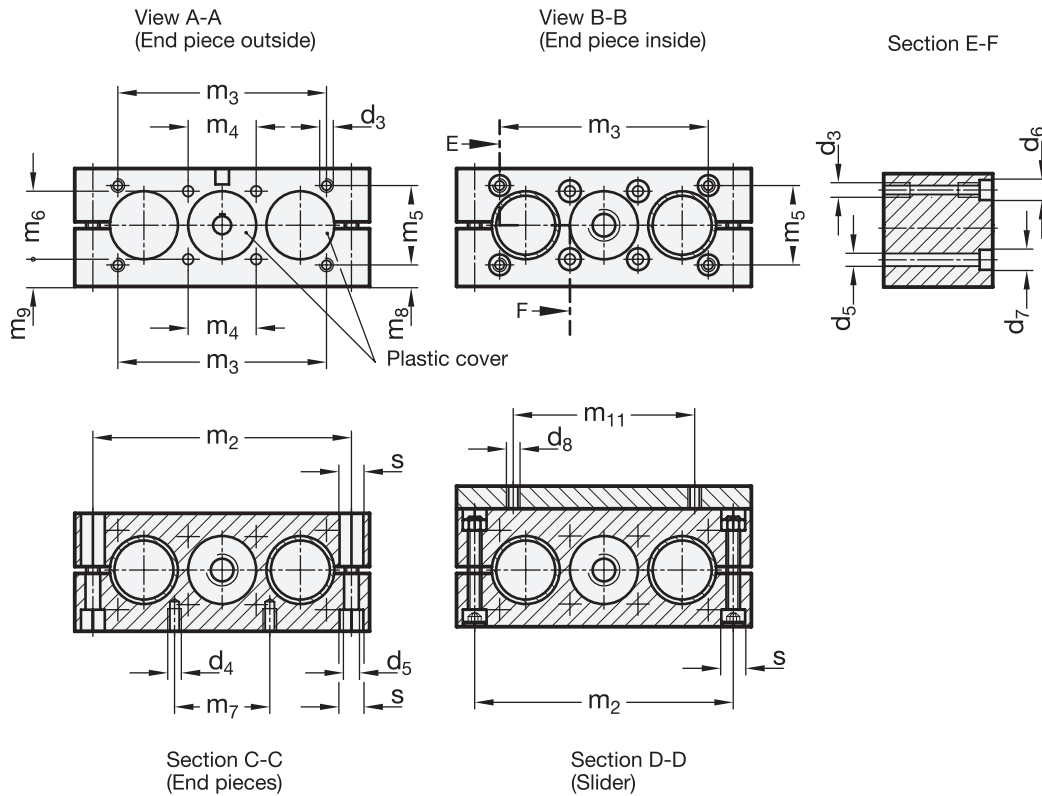

Standard Elements	Main dimensions																		Key DIN 6885	Position indi- cator	Hand- wheel	$\Delta$ g
Description	d1	d3**	d4***	d5	d6	#	d7	#	m2	m3	m4	m5	m6	m7	m8	m9	m11	s				
GN 492-30-100-R1-1-SCR	30	M 6	M 6	6.5	10	M 5	11	M 6	114	92	30	35	30	42	9.5	12	80	10	A2x2x12	DD51	GN 923.30	4140
GN 492-30-100-R1-2-SCR	30	M 6	M 6	6.5	10	M 5	11	M 6	114	92	30	35	30	42	9.5	12	80	10	A2x2x12	DD51	GN 923.30	4140
GN 492-30-150-R1-1-SCR	30	M 6	M 6	6.5	10	M 5	11	M 6	114	92	30	35	30	42	9.5	12	80	10	A2x2x12	DD51	GN 923.30	4340
GN 492-30-150-R1-2-SCR	30	M 6	M 6	6.5	10	M 5	11	M 6	114	92	30	35	30	42	9.5	12	80	10	A2x2x12	DD51	GN 923.30	4340
GN 492-30-200-R1-1-SCR	30	M 6	M 6	6.5	10	M 5	11	M 6	114	92	30	35	30	42	9.5	12	80	10	A2x2x12	DD51	GN 923.30	4500
GN 492-30-200-R1-2-SCR	30	M 6	M 6	6.5	10	M 5	11	M 6	114	92	30	35	30	42	9.5	12	80	10	A2x2x12	DD51	GN 923.30	4500
GN 492-30-300-R1-1-SCR	30	M 6	M 6	6.5	10	M 5	11	M 6	114	92	30	35	30	42	9.5	12	80	10	A2x2x12	DD51	GN 923.30	4900
GN 492-30-300-R1-2-SCR	30	M 6	M 6	6.5	10	M 5	11	M 6	114	92	30	35	30	42	9.5	12	80	10	A2x2x12	DD51	GN 923.30	4900
GN 492-50-100-R1-1-SCR	50	M 10	M 8	8.5	15	M 8	15	M 8	184	150	46	50	46	62	13	15	134	13	A4x4x12	DD52R	GN 924.50	13900
GN 492-50-100-R1-2-SCR	50	M 10	M 8	8.5	15	M 8	15	M 8	184	150	46	50	46	62	13	15	134	13	A4x4x12	DD52R	GN 924.50	13900
GN 492-50-150-R1-1-SCR	50	M 10	M 8	8.5	15	M 8	15	M 8	184	150	46	50	46	62	13	15	134	13	A4x4x12	DD52R	GN 924.50	14400
GN 492-50-150-R1-2-SCR	50	M 10	M 8	8.5	15	M 8	15	M 8	184	150	46	50	46	62	13	15	134	13	A4x4x12	DD52R	GN 924.50	14400
GN 492-50-200-R1-1-SCR	50	M 10	M 8	8.5	15	M 8	15	M 8	184	150	46	50	46	62	13	15	134	13	A4x4x12	DD52R	GN 924.50	14860
GN 492-50-200-R1-2-SCR	50	M 10	M 8	8.5	15	M 8	15	M 8	184	150	46	50	46	62	13	15	134	13	A4x4x12	DD52R	GN 924.50	14860
GN 492-50-300-R1-1-SCR	50	M 10	M 8	8.5	15	M 8	15	M 8	184	150	46	50	46	62	13	15	134	13	A4x4x12	DD52R	GN 924.50	16020
GN 492-50-300-R1-2-SCR	50	M 10	M 8	8.5	15	M 8	15	M 8	184	150	46	50	46	62	13	15	134	13	A4x4x12	DD52R	GN 924.50	16020
GN 492-30-100-L1-1-SCR*	30	M 6	M 6	6.5	10	M 5	11	M 6	114	92	30	35	30	42	9.5	12	80	10	A2x2x12	DD51	GN 923.30	4140
GN 492-30-100-L1-2-SCR*	30	M 6	M 6	6.5	10	M 5	11	M 6	114	92	30	35	30	42	9.5	12	80	10	A2x2x12	DD51	GN 923.30	4140
GN 492-30-150-L1-1-SCR*	30	M 6	M 6	6.5	10	M 5	11	M 6	114	92	30	35	30	42	9.5	12	80	10	A2x2x12	DD51	GN 923.30	4340
GN 492-30-150-L1-2-SCR*	30	M 6	M 6	6.5	10	M 5	11	M 6	114	92	30	35	30	42	9.5	12	80	10	A2x2x12	DD51	GN 923.30	4340
GN 492-30-200-L1-1-SCR*	30	M 6	M 6	6.5	10	M 5	11	M 6	114	92	30	35	30	42	9.5	12	80	10	A2x2x12	DD51	GN 923.30	4500
GN 492-30-200-L1-2-SCR*	30	M 6	M 6	6.5	10	M 5	11	M 6	114	92	30	35	30	42	9.5	12	80	10	A2x2x12	DD51	GN 923.30	4500
GN 492-30-300-L1-1-SCR*	30	M 6	M 6	6.5	10	M 5	11	M 6	114	92	30	35	30	42	9.5	12	80	10	A2x2x12	DD51	GN 923.30	4900
GN 492-30-300-L1-2-SCR*	30	M 6	M 6	6.5	10	M 5	11	M 6	114	92	30	35	30	42	9.5	12	80	10	A2x2x12	DD51	GN 923.30	4900

Standard Elements	Main dimensions																		Key DIN 6885	Position indi- cator	Hand- wheel	 g
	Description	d1	d3**	d4***	d5	d6	#	d7	#	m2	m3	m4	m5	m6	m7	m8	m9	m11				
GN 492-50-100-L1-1-SCR*	50	M 10	M 8	8.5	15	M 8	15	M 8	184	150	46	50	46	62	13	15	134	13	A4x4x12	DD52R	GN 924.50	13900
GN 492-50-100-L1-2-SCR*	50	M 10	M 8	8.5	15	M 8	15	M 8	184	150	46	50	46	62	13	15	134	13	A4x4x12	DD52R	GN 924.50	13900
GN 492-50-150-L1-1-SCR*	50	M 10	M 8	8.5	15	M 8	15	M 8	184	150	46	50	46	62	13	15	134	13	A4x4x12	DD52R	GN 924.50	14400
GN 492-50-150-L1-2-SCR*	50	M 10	M 8	8.5	15	M 8	15	M 8	184	150	46	50	46	62	13	15	134	13	A4x4x12	DD52R	GN 924.50	14400
GN 492-50-200-L1-1-SCR*	50	M 10	M 8	8.5	15	M 8	15	M 8	184	150	46	50	46	62	13	15	134	13	A4x4x12	DD52R	GN 924.50	14860
GN 492-50-200-L1-2-SCR*	50	M 10	M 8	8.5	15	M 8	15	M 8	184	150	46	50	46	62	13	15	134	13	A4x4x12	DD52R	GN 924.50	14860
GN 492-50-300-L1-1-SCR*	50	M 10	M 8	8.5	15	M 8	15	M 8	184	150	46	50	46	62	13	15	134	13	A4x4x12	DD52R	GN 924.50	16020
GN 492-50-300-L1-2-SCR*	50	M 10	M 8	8.5	15	M 8	15	M 8	184	150	46	50	46	62	13	15	134	13	A4x4x12	DD52R	GN 924.50	16020
GN 492-30-100-R2-1-SCR*	30	M 6	M 6	6.5	10	M 5	11	M 6	114	92	30	35	30	42	9.5	12	80	10	A2x2x12	DD51	GN 923.30	4140
GN 492-30-100-R2-2-SCR*	30	M 6	M 6	6.5	10	M 5	11	M 6	114	92	30	35	30	42	9.5	12	80	10	A2x2x12	DD51	GN 923.30	4140
GN 492-30-100-R2-3-SCR*	30	M 6	M 6	6.5	10	M 5	11	M 6	114	92	30	35	30	42	9.5	12	80	10	A2x2x12	DD51	GN 923.30	4140
GN 492-30-150-R2-1-SCR*	30	M 6	M 6	6.5	10	M 5	11	M 6	114	92	30	35	30	42	9.5	12	80	10	A2x2x12	DD51	GN 923.30	4340
GN 492-30-150-R2-2-SCR*	30	M 6	M 6	6.5	10	M 5	11	M 6	114	92	30	35	30	42	9.5	12	80	10	A2x2x12	DD51	GN 923.30	4340
GN 492-30-150-R2-3-SCR*	30	M 6	M 6	6.5	10	M 5	11	M 6	114	92	30	35	30	42	9.5	12	80	10	A2x2x12	DD51	GN 923.30	4340
GN 492-30-200-R2-1-SCR*	30	M 6	M 6	6.5	10	M 5	11	M 6	114	92	30	35	30	42	9.5	12	80	10	A2x2x12	DD51	GN 923.30	4500
GN 492-30-200-R2-2-SCR*	30	M 6	M 6	6.5	10	M 5	11	M 6	114	92	30	35	30	42	9.5	12	80	10	A2x2x12	DD51	GN 923.30	4500
GN 492-30-200-R2-3-SCR*	30	M 6	M 6	6.5	10	M 5	11	M 6	114	92	30	35	30	42	9.5	12	80	10	A2x2x12	DD51	GN 923.30	4500
GN 492-30-300-R2-1-SCR*	30	M 6	M 6	6.5	10	M 5	11	M 6	114	92	30	35	30	42	9.5	12	80	10	A2x2x12	DD51	GN 923.30	4900
GN 492-30-300-R2-2-SCR*	30	M 6	M 6	6.5	10	M 5	11	M 6	114	92	30	35	30	42	9.5	12	80	10	A2x2x12	DD51	GN 923.30	4900
GN 492-30-300-R2-3-SCR*	30	M 6	M 6	6.5	10	M 5	11	M 6	114	92	30	35	30	42	9.5	12	80	10	A2x2x12	DD51	GN 923.30	4900
GN 492-50-100-R2-1-SCR*	50	M 10	M 8	8.5	15	M 8	15	M 8	184	150	46	50	46	62	13	15	134	13	A4x4x12	DD52R	GN 924.50	13900
GN 492-50-100-R2-2-SCR*	50	M 10	M 8	8.5	15	M 8	15	M 8	184	150	46	50	46	62	13	15	134	13	A4x4x12	DD52R	GN 924.50	13900
GN 492-50-100-R2-3-SCR*	50	M 10	M 8	8.5	15	M 8	15	M 8	184	150	46	50	46	62	13	15	134	13	A4x4x12	DD52R	GN 924.50	13900
GN 492-50-150-R2-1-SCR*	50	M 10	M 8	8.5	15	M 8	15	M 8	184	150	46	50	46	62	13	15	134	13	A4x4x12	DD52R	GN 924.50	14400
GN 492-50-150-R2-2-SCR*	50	M 10	M 8	8.5	15	M 8	15	M 8	184	150	46	50	46	62	13	15	134	13	A4x4x12	DD52R	GN 924.50	14400
GN 492-50-150-R2-3-SCR*	50	M 10	M 8	8.5	15	M 8	15	M 8	184	150	46	50	46	62	13	15	134	13	A4x4x12	DD52R	GN 924.50	14400
GN 492-50-200-R2-1-SCR*	50	M 10	M 8	8.5	15	M 8	15	M 8	184	150	46	50	46	62	13	15	134	13	A4x4x12	DD52R	GN 924.50	14860
GN 492-50-200-R2-2-SCR*	50	M 10	M 8	8.5	15	M 8	15	M 8	184	150	46	50	46	62	13	15	134	13	A4x4x12	DD52R	GN 924.50	14860
GN 492-50-200-R2-3-SCR*	50	M 10	M 8	8.5	15	M 8	15	M 8	184	150	46	50	46	62	13	15	134	13	A4x4x12	DD52R	GN 924.50	14860
GN 492-50-300-R2-1-SCR*	50	M 10	M 8	8.5	15	M 8	15	M 8	184	150	46	50	46	62	13	15	134	13	A4x4x12	DD52R	GN 924.50	16020
GN 492-50-300-R2-2-SCR*	50	M 10	M 8	8.5	15	M 8	15	M 8	184	150	46	50	46	62	13	15	134	13	A4x4x12	DD52R	GN 924.50	16020
GN 492-50-300-R2-3-SCR*	50	M 10	M 8	8.5	15	M 8	15	M 8	184	150	46	50	46	62	13	15	134	13	A4x4x12	DD52R	GN 924.50	16020
GN 492-30-100-L2-1-SCR*	30	M 6	M 6	6.5	10	M 5	11	M 6	114	92	30	35	30	42	9.5	12	80	10	A2x2x12	DD51	GN 923.30	4140
GN 492-30-100-L2-2-SCR*	30	M 6	M 6	6.5	10	M 5	11	M 6	114	92	30	35	30	42	9.5	12	80	10	A2x2x12	DD51	GN 923.30	4140
GN 492-30-100-L2-3-SCR*	30	M 6	M 6	6.5	10	M 5	11	M 6	114	92	30	35	30	42	9.5	12	80	10	A2x2x12	DD51	GN 923.30	4140
GN 492-30-150-L2-1-SCR*	30	M 6	M 6	6.5	10	M 5	11	M 6	114	92	30	35	30	42	9.5	12	80	10	A2x2x12	DD51	GN 923.30	4340
GN 492-30-150-L2-2-SCR*	30	M 6	M 6	6.5	10	M 5	11	M 6	114	92	30	35	30	42	9.5	12	80	10	A2x2x12	DD51	GN 923.30	4340
GN 492-30-150-L2-3-SCR*	30	M 6	M 6	6.5	10	M 5	11	M 6	114	92	30	35	30	42	9.5	12	80	10	A2x2x12	DD51	GN 923.30	4340
GN 492-30-200-L2-1-SCR*	30	M 6	M 6	6.5	10	M 5	11	M 6	114	92	30	35	30	42	9.5	12	80	10	A2x2x12	DD51	GN 923.30	4500
GN 492-30-200-L2-2-SCR*	30	M 6	M 6	6.5	10	M 5	11	M 6	114	92	30	35	30	42	9.5	12	80	10	A2x2x12	DD51	GN 923.30	4500
GN 492-30-200-L2-3-SCR*	30	M 6	M 6	6.5	10	M 5	11	M 6	114	92	30	35	30	42	9.5	12	80	10	A2x2x12	DD51	GN 923.30	4500
GN 492-30-300-L2-1-SCR*	30	M 6	M 6	6.5	10	M 5	11	M 6	114	92	30	35	30	42	9.5	12	80	10	A2x2x12	DD51	GN 923.30	4900
GN 492-30-300-L2-2-SCR*	30	M 6	M 6	6.5	10	M 5	11	M 6	114	92	30	35	30	42	9.5	12	80	10	A2x2x12	DD51	GN 923.30	4900
GN 492-30-300-L2-3-SCR*	30	M 6	M 6	6.5	10	M 5	11	M 6	114	92	30	35	30	42	9.5	12	80	10	A2x2x12	DD51	GN 923.30	4900

Standard Elements Description	Main dimensions																		Key DIN 6885	Position indi- cator	Hand- wheel	g
	d1	d3**	d4***	d5	d6	#	d7	#	m2	m3	m4	m5	m6	m7	m8	m9	m11	s				
GN 492-50-100-L2-1-SCR*	50	M 10	M 8	8.5	15	M 8	15	M 8	184	150	46	50	46	62	13	15	134	13	A4x4x12	DD52R	GN 924.50	13900
GN 492-50-100-L2-2-SCR*	50	M 10	M 8	8.5	15	M 8	15	M 8	184	150	46	50	46	62	13	15	134	13	A4x4x12	DD52R	GN 924.50	13900
GN 492-50-100-L2-3-SCR*	50	M 10	M 8	8.5	15	M 8	15	M 8	184	150	46	50	46	62	13	15	134	13	A4x4x12	DD52R	GN 924.50	13900
GN 492-50-150-L2-1-SCR*	50	M 10	M 8	8.5	15	M 8	15	M 8	184	150	46	50	46	62	13	15	134	13	A4x4x12	DD52R	GN 924.50	14400
GN 492-50-150-L2-2-SCR*	50	M 10	M 8	8.5	15	M 8	15	M 8	184	150	46	50	46	62	13	15	134	13	A4x4x12	DD52R	GN 924.50	14400
GN 492-50-150-L2-3-SCR*	50	M 10	M 8	8.5	15	M 8	15	M 8	184	150	46	50	46	62	13	15	134	13	A4x4x12	DD52R	GN 924.50	14400
GN 492-50-200-L2-1-SCR*	50	M 10	M 8	8.5	15	M 8	15	M 8	184	150	46	50	46	62	13	15	134	13	A4x4x12	DD52R	GN 924.50	14860
GN 492-50-200-L2-2-SCR*	50	M 10	M 8	8.5	15	M 8	15	M 8	184	150	46	50	46	62	13	15	134	13	A4x4x12	DD52R	GN 924.50	14860
GN 492-50-200-L2-3-SCR*	50	M 10	M 8	8.5	15	M 8	15	M 8	184	150	46	50	46	62	13	15	134	13	A4x4x12	DD52R	GN 924.50	14860
GN 492-50-300-L2-1-SCR*	50	M 10	M 8	8.5	15	M 8	15	M 8	184	150	46	50	46	62	13	15	134	13	A4x4x12	DD52R	GN 924.50	16020
GN 492-50-300-L2-2-SCR*	50	M 10	M 8	8.5	15	M 8	15	M 8	184	150	46	50	46	62	13	15	134	13	A4x4x12	DD52R	GN 924.50	16020
GN 492-50-300-L2-3-SCR*	50	M 10	M 8	8.5	15	M 8	15	M 8	184	150	46	50	46	62	13	15	134	13	A4x4x12	DD52R	GN 924.50	16020

\* normally not available from stock  
 \*\* useable depth of thread min. 2 x d3  
 \*\*\* useable depth of thread min. 1.5 x d4  
 # for screw DIN 912

### Mounting facilities of the end pieces

#### Horizontal

with screws for thread d4 or bore d5

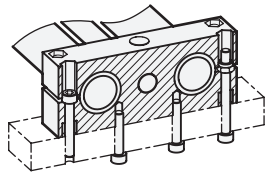

#### Vertical

from outside with screws for thread d3  
 from inside with screws for bore d6  
 from inside with screws for bore d5 / d7

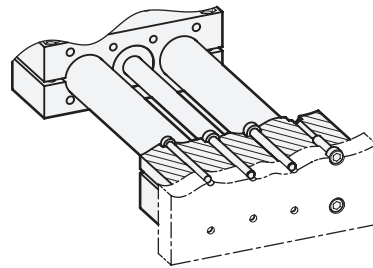

### Mounting facilities at the slider

Mounting with screws for thread d8

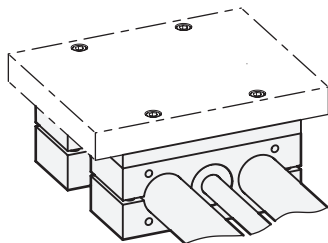

# Technical descriptions of the double tube linear actuators

GN 491

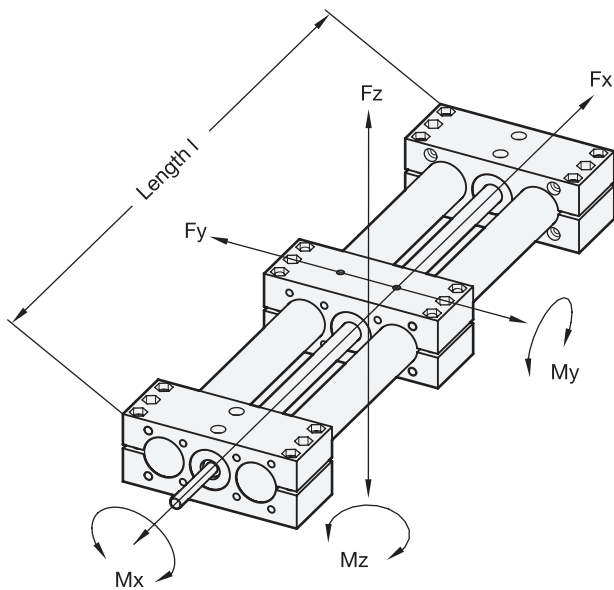

GN 492

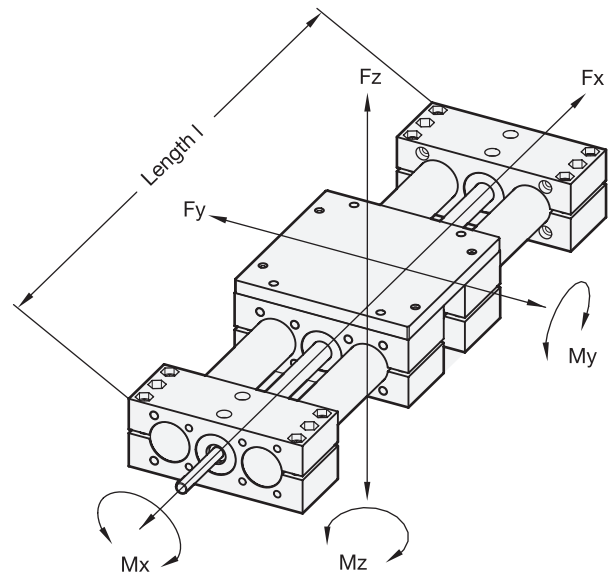

d	F <sub>x</sub> in N	F <sub>y</sub> in N for l =			F <sub>z</sub> in N for l =			M <sub>x</sub>	M <sub>y</sub>	M <sub>z</sub>
GN 491		500	1000	1500	500	1000	1500	in Nm	in Nm	in Nm
30	850	1100	900	550	600	350	150	100	100	100
50	1900	3850	2400	2100	3100	700	200	180	220	290

d	F <sub>x</sub> in N	F <sub>y</sub> in N for l =			F <sub>z</sub> in N for l =			M <sub>x</sub>	M <sub>y</sub>	M <sub>z</sub>
GN 492		500	1000	1500	500	1000	1500	in Nm	in Nm	in Nm
30	850	1550	1300	800	700	550	250	150	150	200
50	1900	7500	5100	2700	3400	850	340	250	350	530

The specified forces F<sub>y</sub> and F<sub>z</sub> cause a flexure of the guide tube of approx. 0.5 mm.

## Description

The slider is moved via a bearing-type trapezoidal thread spindle and a guide nut. The slider is guided through two parallel chrome-plated tubes, resulting in a high load capacity and allowing high bending moments to be compensated by the linear actuator.

For type GN 492, a second slider and an adapter plate extend the options for applications.

These double tube linear actuators have been designed for manual operation (handwheel). With the appropriate lubrication, they can also absorb rotary spindle speeds of as much as 250 rpm.

The positioning accuracy is 0.2 mm / 300 mm travel, the maximum reverse play is 0.1 mm.

To measure the adjustment or the positioning, digital position indicators GN DD5R (see catalogue new products 038.1 page 266) / DD51 (see catalogue new products 038.1 page 262) may be attached.

Further information see on the standard pages of GN 491 (see page 2) and GN 492 (see page 8).



# Designs of the double tube linear actuators

## Description

Double tube linear actuators  
**GN 491 / GN 492**  
 (page 2 / page 4)  
 with right or left hand thread,  
 single shaft end or two shaft ends.

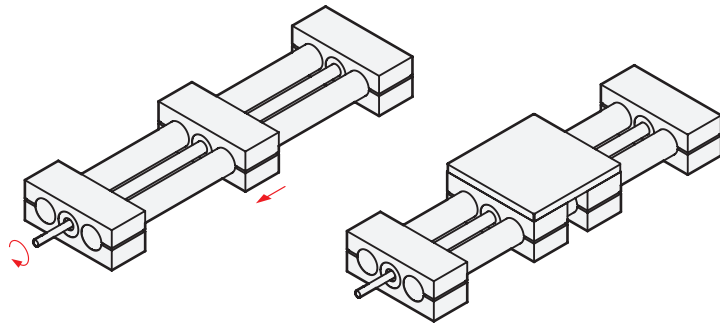

**GN 491**

**GN 492**

## Description

Double tube linear actuators  
**GN 493 / GN 494**  
 with right and left hand thread,  
 single shaft end or two shaft ends,  
 both sliders move symmetrically.

Double tube linear actuators  
**GN 493 / GN 494** on request.

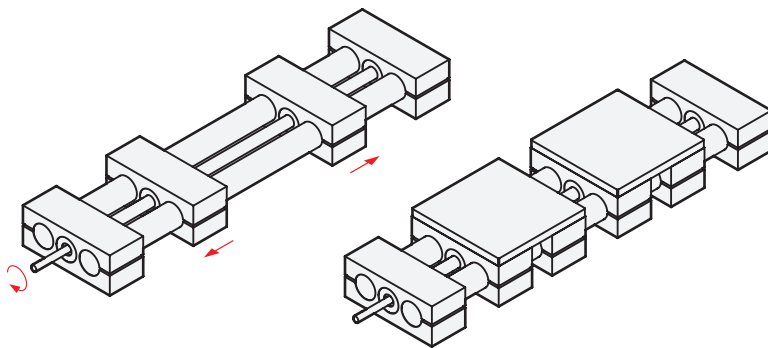

**GN 493**

**GN 494**

## Description

Double tube linear actuators  
**GN 495 / GN 496**  
 with two separate spindles,  
 each with right or left hand thread, both  
 sliders move independently of each other.

Double tube linear actuators  
**GN 495 / GN 496** on request.

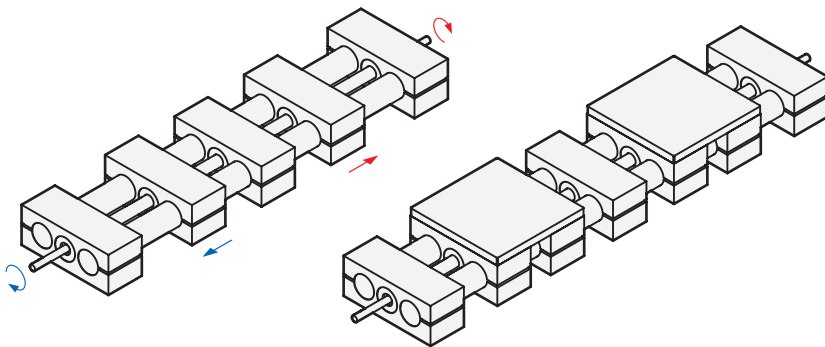

**GN 495**

**GN 496**

## Electronic catalogue

The electronic version of the Elesa+Ganter General Catalogue on DVD or on [www.elesa-ganter.com](http://www.elesa-ganter.com) offers the design-engineer the possibility to search for the right element for the application either by going through the catalogue pages on the video or by selecting from the menus.

For each product series you can find:

- colour photos
- technical information
- line drawings and related dimension tables
- 2D CAD drawings
- 3D CAD drawings



2D CAD drawings



3D CAD drawings

3D CAD drawings are available on the [www.elesa-ganter.com](http://www.elesa-ganter.com) website almost in all formats.

[www.elesa-ganter.com](http://www.elesa-ganter.com)



Distributed by



OTTO GANTER GmbH & Co.KG  
Triberger Straße 3  
78120 Furtwangen GERMANY  
Phone: +49 7723 65 07 130  
Fax: +49 7723 65 07 165  
[www.ganter-griff.com](http://www.ganter-griff.com)  
[info@ganter-griff.de](mailto:info@ganter-griff.de)

ELESA S.p.A.  
Via Pompei 29  
20900 Monza (MB) ITALY  
Phone: +39 039 28 11.1  
Fax: +39 039 83 63 51  
[www.elesa.com](http://www.elesa.com)  
[info@elesa.com](mailto:info@elesa.com)

[www.elesa-ganter.com](http://www.elesa-ganter.com)