

Positioning Systems

Linear Motor Systems

Positioning Systems

Linear Motor Systems

HIWIN positioning systems facilitate positioning that is accurate in terms of time and location. These positioning systems are suitable for installation in a horizontal or vertical position. Due to the direct drive, they are free of backlash, very dynamic and are low maintenance.



Assembly instructions and catalogue for download

Here you can download the corresponding assembly instruction and the current catalogue as PDF files.

Linear Motor Systems

Contents

Contents

1	Product overview	7
2	General information	8
2.1	Glossary	8
2.2	Typical parameters	9
2.3	Typical properties of linear motor axes	10
2.4	General layout of the linear motor axes	10
2.5	Drive amplifiers for linear motor axes	11
2.6	General specifications for linear motor axes	11
3	Linear motor axis LMSSA	12
3.1	Properties of the LMSSA linear motor axes	12
3.2	Order code for LMSSA linear motor axes	13
3.3	Linear motor axis LMSSA specifications	14
4	Linear motor axis LMX1A	60
4.1	Properties of the LMX1A linear motor axes	60
4.2	Order code for LMX1A linear motor axes	60
4.3	Energy supply for linear motor axes LMX1A	60
4.4	Linear motor axis LMX1A specifications	61
5	Linear motor axis LMX1E	76
5.1	Properties of the LMX1E linear motor axes	76
5.2	Order code for LMX1E linear motor axes	76
5.3	Energy supply for linear motor axes LMX1A	77
5.4	Linear motor axis LMX1E specifications	77
6	High-speed linear motor axis LMV	86
6.1	Properties of the LMV linear motor axes	86
6.2	Order code for LMV linear motor axes	86
6.3	Linear motor axis LMV specifications	87
7	Cross table LMX2E	88
7.1	Properties of the LMX2E cross tables	88
7.2	Order code for LMX2E cross tables	88
7.3	Cross table LMX2E specifications	88
8	Gantry system LMG2A-C	91
8.1	Properties of the LMG2A-C gantry systems	91
8.2	Order code for LMG2A-C gantry systems	91
8.3	Gantry system LMG2A-C specifications	91
9	Customized positioning systems	93
9.1	Examples	93

Linear Motor Systems

Product overview

1. Product overview



LMSSA

[Page 12](#)

- Short delivery time
- Cost-optimised linear motor axis, based on standardised modular system with reduced number of variants
- With iron-core LMSA motors or with coreless LMC motors
- Stroke length is measured via optical or magnetic distance measuring system incrementally or absolutely depending on requirements



LMX1A

[Page 60](#)

- Complete axis with iron-core motor, type LMSA
- Ideal for applications with high continuous power requirements
- Optional enclosure by metal cover or bellow cover
- Stroke length is measured via optical or magnetic distance measuring system incrementally or absolutely depending on requirements



LMX1E

[Page 76](#)

- Complete axis with coreless motor, type LMC
- Ideal for applications with a high degree of synchronization requirements
- Optional enclosure by metal cover or bellow cover
- Stroke length is measured via optical distance measuring system incrementally or absolutely

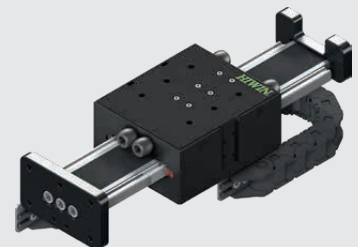

LMV

[Page 86](#)

- Highly dynamic positioning axis, for vertical and horizontal applications
- Compact, zero-play setup
- Maximised mechanical rigidity
- Protected against dust

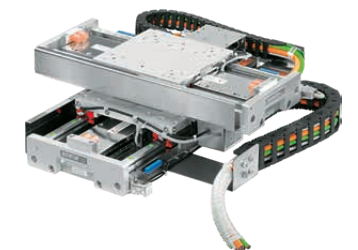

Cross tables

[Page 88](#)

- Combination of axes from the LMX series

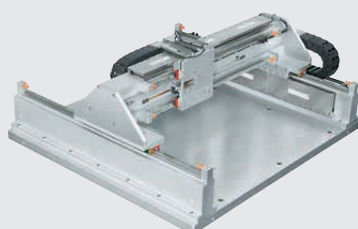

Gantry systems

[Page 91](#)

- Standardized gantry systems

Linear Motor Systems

General information

2. General information

2.1 Glossary

Acceleration

This is the speed change per time unit, that is
 $\text{acceleration} = \text{speed}/\text{time}$ or $a = v/t$.

Acceleration time

This is defined as the time that a drive requires to reach maximum speed from standstill.

Accuracy (absolute accuracy)

This, or the actual inaccuracy, corresponds to the deviation between a targeted position and the actual position. The accuracy along an axis is defined as the difference between the actual and target positions after all other linear deviations that can be eliminated have been excluded. Such systematic and linear deviations are the result, for example, of cosine errors, angle deviations, shaft lead errors, thermal expansion etc. Accuracy is calculated for all relevant target positions of an application using to the following formula:

Maximum of all sums of systematic target-actual deviations + 2 sigma (standard deviation). Accuracy must not be confused with \triangleright repeatability.

Back EMF constant K_v

This is the relation between the back EMF voltage (rms) and the motor rotational speed or speed (rpm or m/s). Back EMF is the electromagnetic force that is created during the movement of windings in the magnetic field of permanent magnets, e.g. in a servo motor.

Continuous torque, continuous force F_c

A motor can produce continuous torque or nominal torque (with rotational movements) and continuous force or nominal force (with linear movements) in continuous operation (duty cycle = 100 %).

Continuous current I_c

This is the current supplied over a longer period; the maximum permitted continuous current per winding is referred to as the nominal current. The continuous current is characterized by the fact that the dissipation power results in motor warming of T_{max} .

Eccentricity

This is the deviation of the center point of rotation of rotary tables from its position during rotation. It is created by centering and bearing tolerances.

Flatness

This is a measure for the vertical straightness of a movement on the X-axis. A deviation from the absolute levelness is a shift on the Z-axis when moving on the X-axis.

Force, torque

Force (in linear movements) or torque (in rotational movements) is given for defined conditions, e.g. as continuous force or continuous torque at:

- 25 °C ambient temperature
- T_{max} winding temperature
- 100 % operating time for linear motors and torque motors
- 50 % operating time for rotary tables

or as peak force or peak torque.

Force constant K_f

This is the winding-specific parameter used to calculate the resultant force as $F = I \times K_f$ by multiplication with the input current.

Guide deviation

This is the linear deviation from the stroke axis. It is dependent on straightness (thus the accuracy at the level of the table) and flatness (the accuracy external to the level of the table).

Increment

The smallest increment is the minimum stroke that a linear drive can travel repeatedly. It is determined by the \triangleright resolution of the linear drive plus the increment of the motor and all errors in the drive line (reverse play, winding etc.).

Magnetic attraction force F_a

This force is created between the primary and secondary parts of iron-core linear motors, by biasing voltage of the drive system, which must then be taken up by the guide.

Motor constant K_m

This designates the ratio of generated power and dissipation power and consequently is a measure for efficiency of a motor.

Multi-Index

One incremental track is arranged on the scale. The sensor in the encoder head reads out 3 signals: incremental tracks A and B and Z-track for the internal reference signal. Each reference mark on the scale creates a reference signal (multi-index). An external reference switch is essential to trigger the reference signal. After operating the external reference switch the next reference mark on the magnetic scale defines the reference signal.

Peak current I_p

It is used for short-term generation of peak power. HIWIN defines peak current as follows: Iron-core motors have three times the permitted continuous current of the LMS series as I_p , coreless motors have three times the permitted continuous current as I_p . The maximum permitted length of peak current is one second. Thereafter, the motor must cool down to the nominal temperature before peak current can be supplied again.

Peak torque, peak force F_p

The peak torque (for rotational movements) or the peak force (for linear movements) is the maximum force that a motor can generate for approximately one second. With HIWIN, it is at the end of the linear modulation range at peak current I_p and is significant especially during acceleration and braking.

Repeatability

This may not be confused with absolute preciseness. A linear axis can have slight preciseness, but high repeatability. The uni-directional repeatability is measured when there is movement to a target position from an appropriately large stroke in the same direction several times; doing this the other way around does not work. In the measurement of bi-direction repeatability, there is movement to a target position is driven from different movement directions; doing this the other way around does work.

Resolution

This is the smallest stroke that can be detected by the distance measuring system in use. The achievable \triangleright increment is usually higher than the resolution due to additional factors.

Rigidity

This corresponds to the mechanical deformation resistance that a component or assembly has against a static external load in a steady-state, static state (static rigidity) or the elastic deformation resistance that a component or assembly has against a dynamic force working from the outside (dynamic rigidity).

Single-Index

The magnetic scale is split in two tracks, incremental track and index track. Depending on the specification one or several reference marks are located on the index track over the entire travel distance. There are two sensors integrated in the encoder: A sensor for the incremental tracks A and B and a sensor for the Z track that outputs a reference signal when passing over one of the reference marks (single index). Single-index-scales are always custom-made

Straightness

This is a measure for the horizontal straightness of a movement on the X-axis. A deviation from the absolute straightness is a shift on the Y-axis when moving on the X-axis.

Torque

This is the dimension which causes a rotation movement in a body and consequently a vectorial dimension, which can be expressed in the following cross product:

$$\vec{M} = \vec{r} \times \vec{F}_1$$

The torque is expressed physically in the unit $\text{Nm} = \text{kgm}^2/\text{s}^2$.

Wobbling

This is the angle deviation in the rotation axis from rotary tables during rotational movements, i.e. tipping of the surface of a rotary table. The causes are mainly tolerances in the bearing.

Winding resistance R_{25}

This is the winding-specific dimension that is produced by the winding resistance at 25 °C winding temperature. At 80 °C winding temperature, the winding resistance increases to approximately $1.2 \times R_{25}$.

Winding temperature T_{max}

This is the permitted winding temperature. The actual motor temperature is dependent on the installation, cooling and operating conditions and consequently can only be determined in an actual case and cannot be calculated.

2.2 Typical parameters

2.2.1 Winding-independent parameters

- F_a Relatively constant force between primary and secondary part (magnetic basis) that must be handled by a mechanical guide.
- F_c Motor power, which is available in nominal operation as continuous force and which results in warming to T_{max} .
- F_p Motor power that can be generated for a short time, which is reached at I_p at the end of the linear modulation range and results in substantial heating up when there is no cooling.
- K_m Motor constant, which expresses the ratio of generated power and dissipation power and consequently the degree of effectiveness.
- P_v The heat output created in the motor winding, which results in a time-dependent temperature rise dependent on the operating mode (current) and the ambient conditions (cooling). P_v is especially high in the upper modulation range (at I_p) due to the quadratic dependency of current, while only relatively slight warming occurs in the range of the nominal current. P_v is calculated using the motor constant K_m for a movement section with the required force F : $P_v = F/K_m$.
- P_{vp} Peak dissipation power at I_p .
- P_c Dissipation power at I_c .
- T Permissible winding temperature, which is recorded by sensors or thermal circuit breakers; the created motor surface temperature is dependent on
 - the actual installation conditions (table size)
 - the heat dissipation conditions (cooling)
 - the operating mode and consequently the mean performance entry and can only be determined if these variables are known.

2.2.2 Winding-independent parameters

- I_c For generating the current flowing for continuous force.
- I_p For short-term generation of the peak force of flowing peak current.
- K_f Winding dimension, which produces the created force with the current:
 $F = I \times K_f$.
- K_u Winding characteristic that in generator mode returns the armature back voltage generated at the motor terminals as a function of the speed: $U_g = K_u \times v$.
- R_{25} Winding resistance at 25 °C; this increases to approx. 1.2 times the value at 80 °C.

Linear Motor Systems

General information

2.3 Typical properties of linear motor axes

HIWIN linear motor axes are directly driven axes with linear motors, which are designed as a plug and play solution. Standardized energy chains and customized cable guides are available as an option. These are suspended complete axes with distance measuring system, guides, limit switches and optionally with covers as protection against environmental influences. An arresting brake can be built in optionally. Due to the direct drive, the linear axes are free from backlash, very dynamic, low maintenance and can also be equipped with several carriages.

- Several carriages per axis
- Can be combined with other axes
- No realignment
- Low maintenance
- Long operating life and high reliability
- Extremely precise and fast positioning
- Smooth running
- High stroke speed
- Compact design, consequently small space requirements
- Optimum accuracy

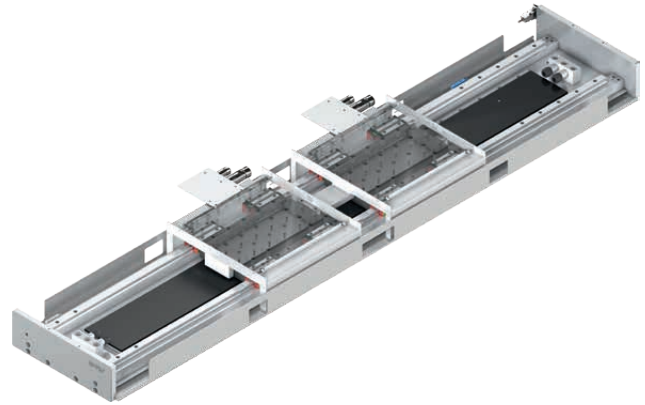

2.4 General layout of the linear motor axes

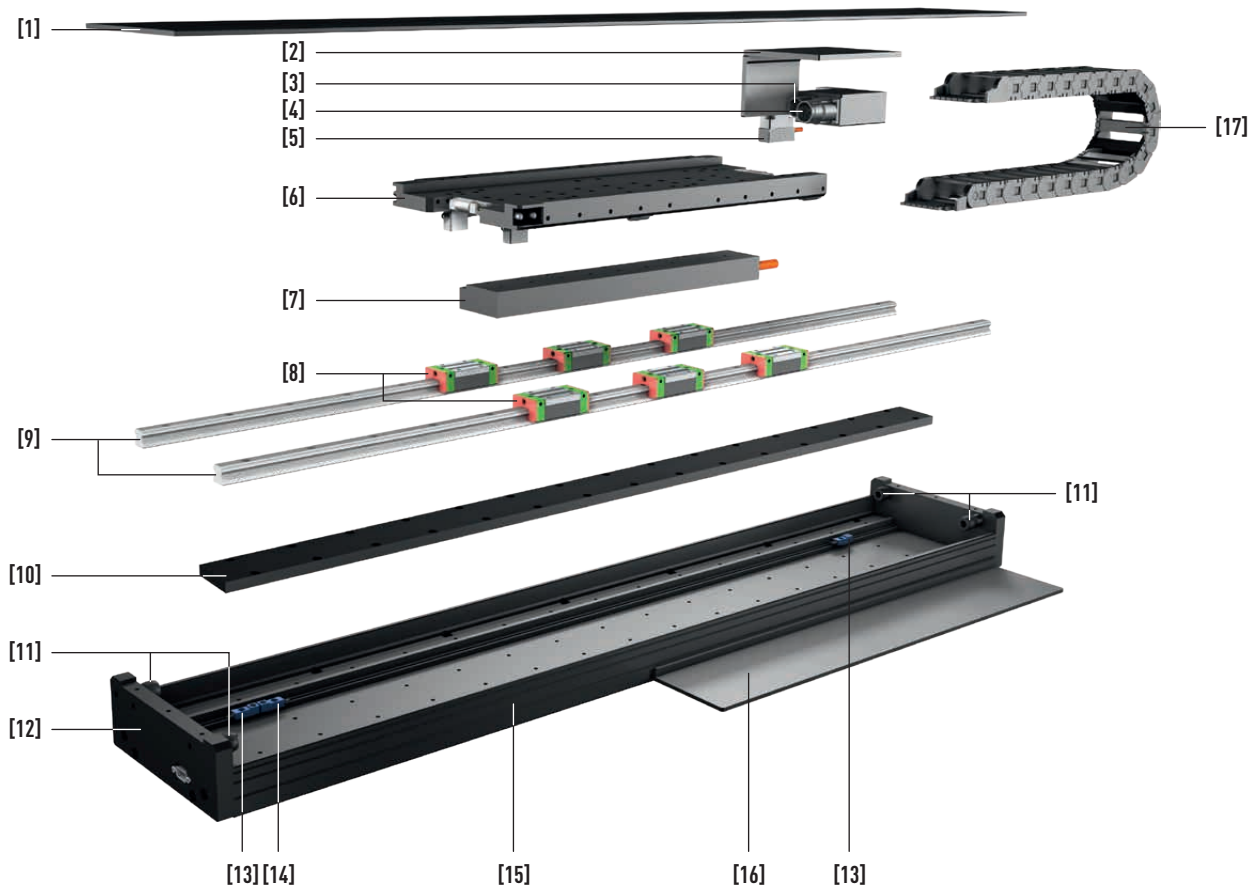

Table 2.1 Main components of the linear motor axis system

Pos.	Component	Pos.	Component
1	Sheet metal cover	10	Stator (secondary part of linear motor)
2	Holding plate for energy chain	11	Stopping buffer
3	Motor plug coupling	12	Profile end caps
4	Encoder plug coupling	13	Limit switch
5	Distance measuring system	14	Reference switch
6	Carriage (forcer carrier plate)	15	Basic profile
7	Forcer (primary part of linear motor)	16	Holding plate for energy chain
8	Linear guideway blocks	17	Energy chain
9	Profile rail		

2.5 Drive amplifiers for linear motor axes

The HIWIN linear motor axes can be operated with HIWIN drives and with all conventional linear motor drives. Some examples of realised projects are listed in the following.



2.6 General specifications for linear motor axes

Table 2.2 General specifications for linear motor axes

Name	Motor type	v_{max} [m/s]	a_{max} [m/s ²]	Total length L_{max} [mm]	Repeatability [mm]	Accuracy ¹⁾ [mm/300 mm]	Straightness [mm]	Flatness [mm]	See
LMSSA-S...	LMSA	5.0	100	3,000	±0.001	±0.002	±0.008/300 mm	±0.008/300 mm	Page 12
LMSSA-C...	LMC	5.0	100	3,000	±0.001	±0.002	±0.008/300 mm	±0.008/300 mm	Page 12
LMX1A-...	LMSA	5.0	50	4,000	±0.001	±0.002	±0.02/500 mm	±0.01/500 mm	Page 60
LMX1E-...	LMC	5.0	100	4,000	±0.001	±0.002	±0.02/500 mm	±0.01/500 mm	Page 76
LMV	LMSA	2.5	50	600	±0.005	±0.010	±0.01/300 mm	±0.01/300 mm	Page 86

¹⁾ At 20 °C, depending on the particular distance measuring system

Linear Motor Systems

Linear motor axis LMSSA

3. Linear motor axis LMSSA

3.1 Properties of the LMSSA linear motor axes

LMSSA linear motor axes are a cost-effective variant of this product group. The cost advantage is achieved by a consistent reduction to the essentials and a limitation of the options and variants available as standard. This allows manufacturing costs to be significantly reduced, while the LMSSA axes simultaneously offer all the advantages of a conventional linear motor axis.

- Short delivery time
- Max. acceleration 100 m/s²
- Max. velocity 5 m/s
- Up to 3,000 mm long



Linear guideway

A high quality HIWIN double guide transfers forces and torques reliably from the carriage into the axis profile. Each carriage comes with four blocks that are guided over two parallel high precision rails. The SynchMotion™ technology with ball chain also ensures a high level of synchronism and quiet running for all sizes.

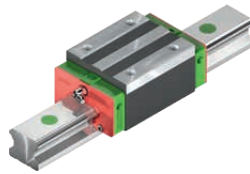

Electrical interface

Motor and encoder cables are routed out directly on the traversing carriage in a cost-optimized manner and are supplied with open cable ends. The limit switch cables are also led out with open cable ends at the front of the axis.



Distance measuring systems

The distance measuring system, that is integrated into the interior of the axis in order to save space, determines the repeatability. Various measuring systems are available, depending on the requirements for measuring method, interface and resolution.



Colour

In addition to the standard grey version (anodized aluminium), the linear motor axis is also available in a black version.



Linear motor

The integrated HIWIN linear motors ensure dynamic and precise positioning. The iron-core LMSA motors are the first choice when high feed forces are required, the ironless motors are the first choice for applications with the highest synchronization requirements.



Cover

The steel cover strip protects the inside of the axis against dust and dirt.

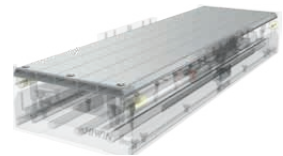

3.2 Order code for LMSSA linear motor axes

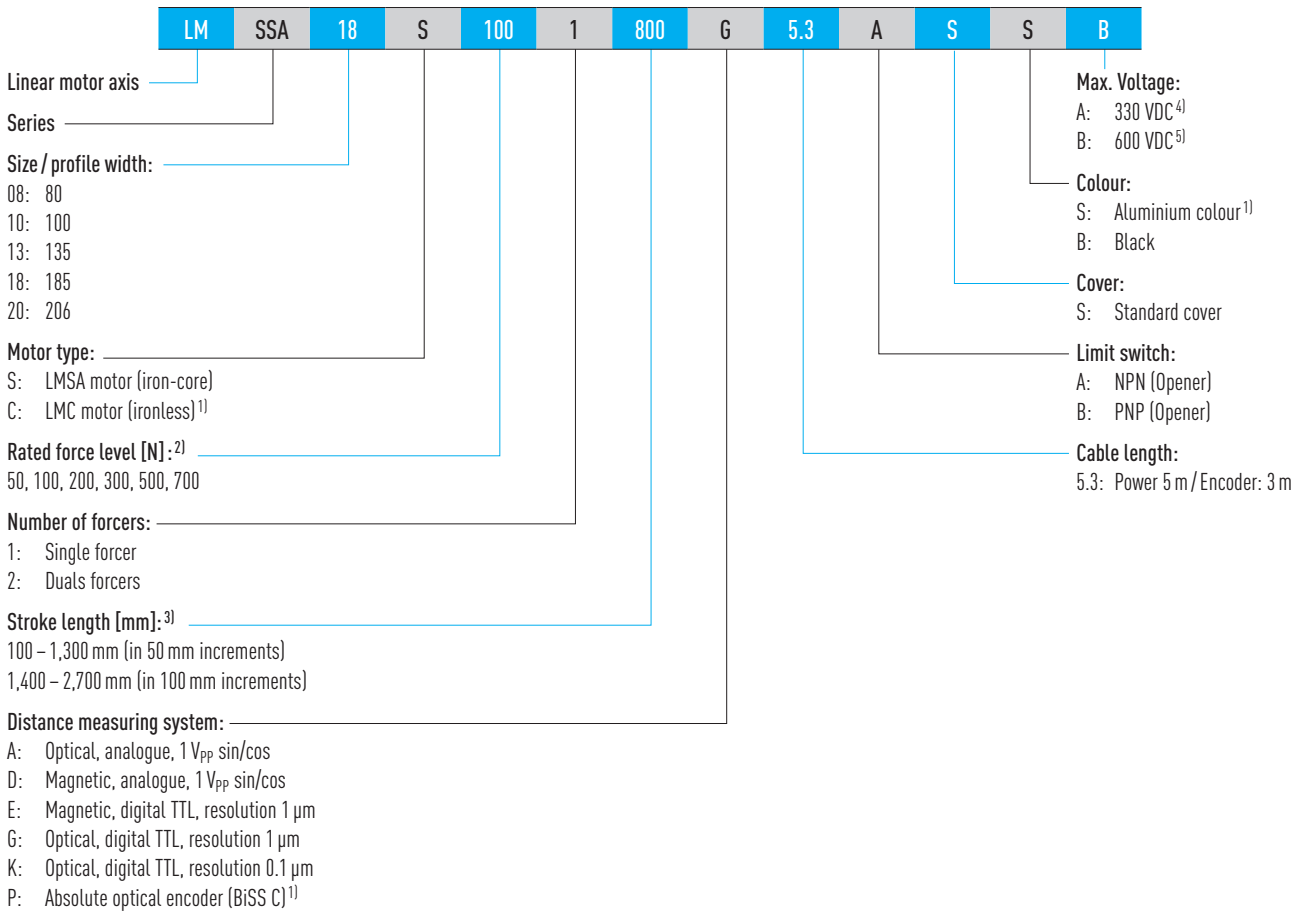

¹⁾ Available for size (profile width) 18 and 20.

²⁾ Rated force depends on motortype. Detailed information from [Table 3.1 on page 19](#).

³⁾ Max. stroke length depends on size (profile width). Detailed information from [Table 3.4 on page 22](#).

⁴⁾ Max. voltage depends on motortype. LMC (ironless) with max. voltage A: 330 VDC

⁵⁾ Max. voltage depends on motortype. LMSA (iron-core) with max. voltage B: 600 VDC

Linear Motor Systems

Linear motor axis LMSSA

3.3 Linear motor axis LMSSA specifications

3.3.1 Characteristic curves LMSSA-S (iron-core)

Force as a function of speed (DC bus voltage: 600 VDC)

LMSSA-08

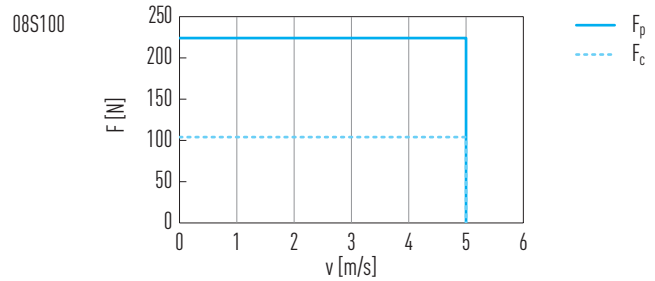
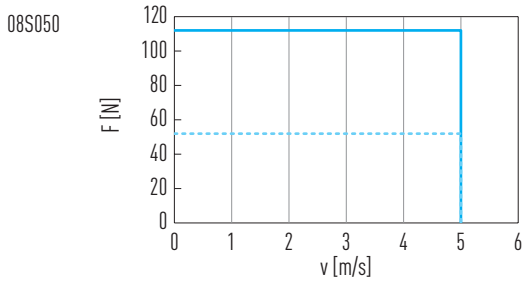

LMSSA-10

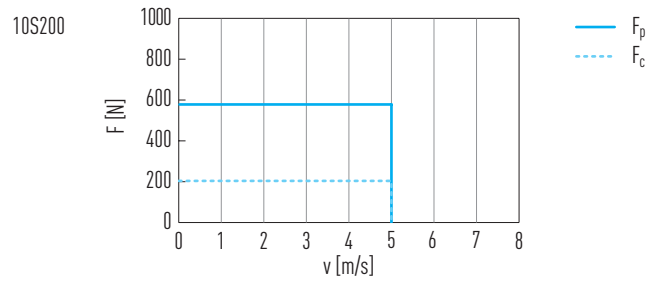
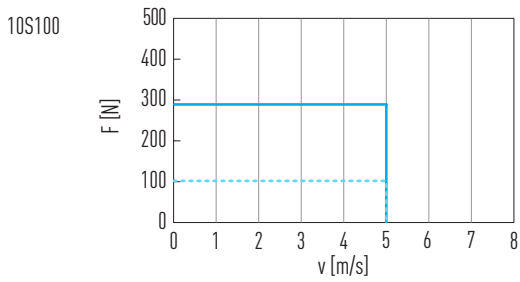

LMSSA-13

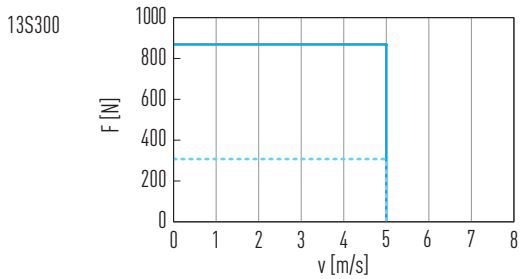
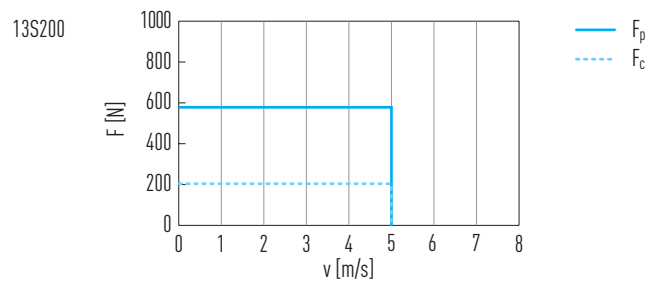
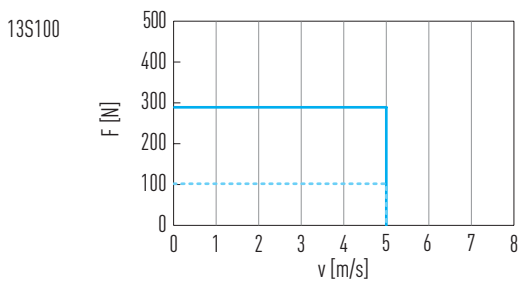

LMSSA-18

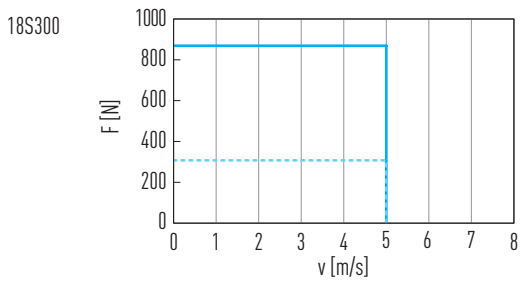
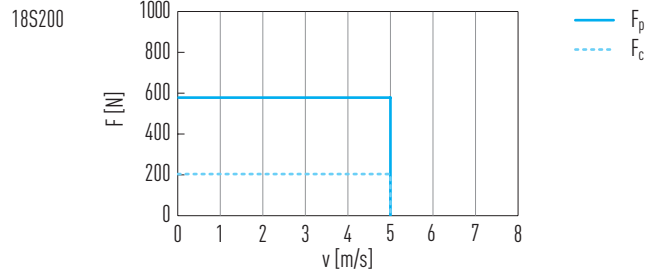
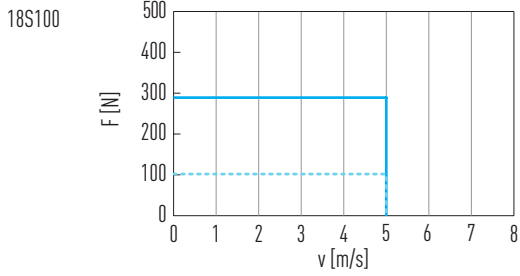

LMSSA-20

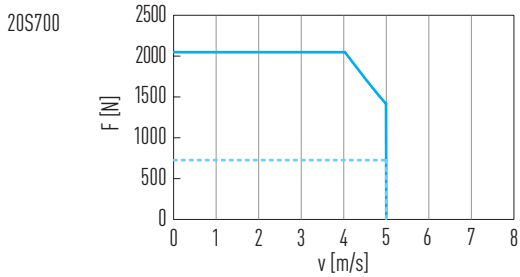
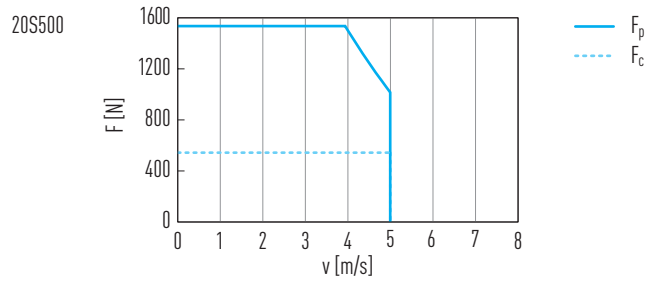
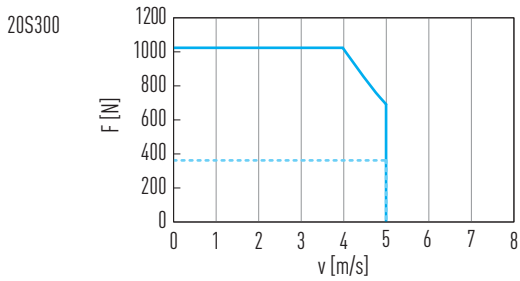

Linear Motor Systems

Linear motor axis LMSSA

Acceleration as a function of speed (DC bus voltage: 600 VDC)

LMSSA-08

08S050

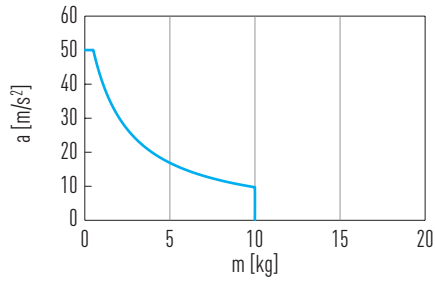

08S100

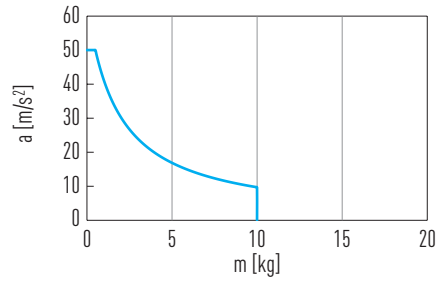

LMSSA-10

10S100

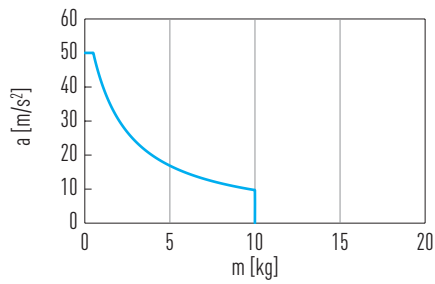

10S200

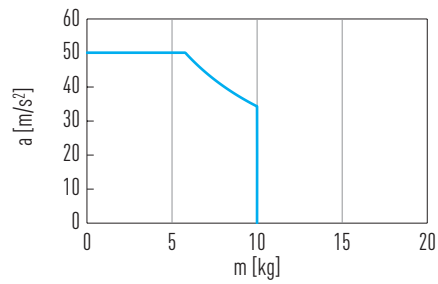

LMSSA-13

13S100

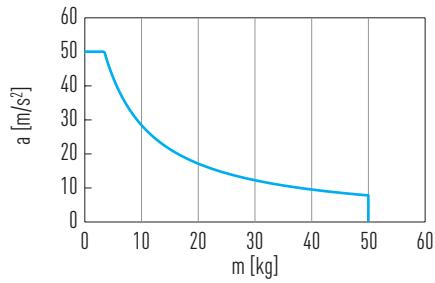

13S200

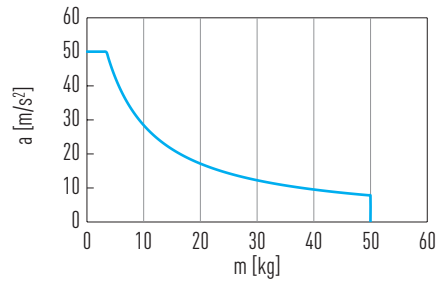

13S300

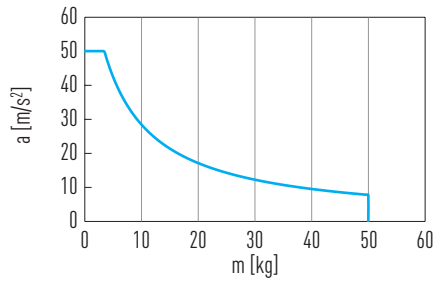

LMSSA-18

18S100

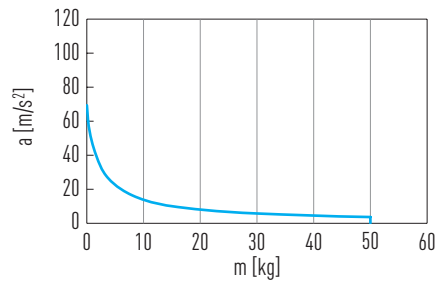

18S200

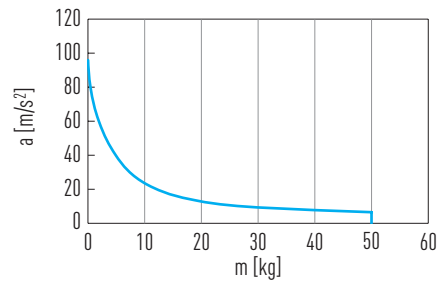

18S300

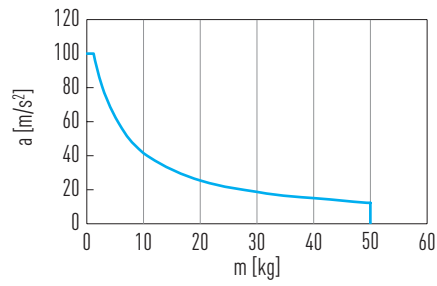

LMSSA-20

20S300

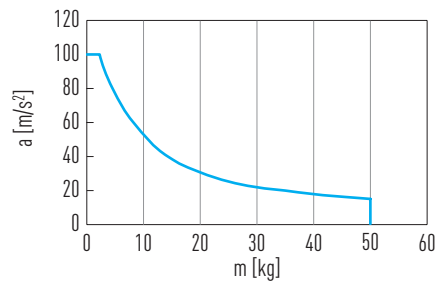

20S500

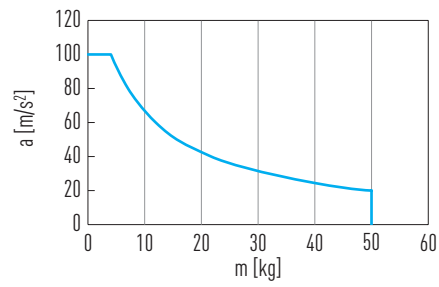

20S700

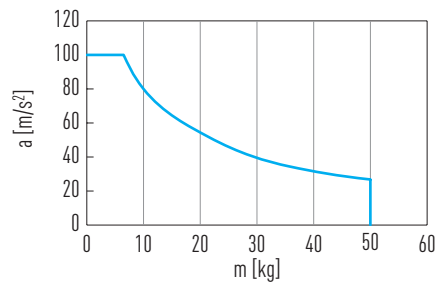

Linear Motor Systems

Linear motor axis LMSSA

3.3.2 Characteristic curves LMSSA-C (ironless)

Force as a function of speed (DC bus voltage: 325 VDC)

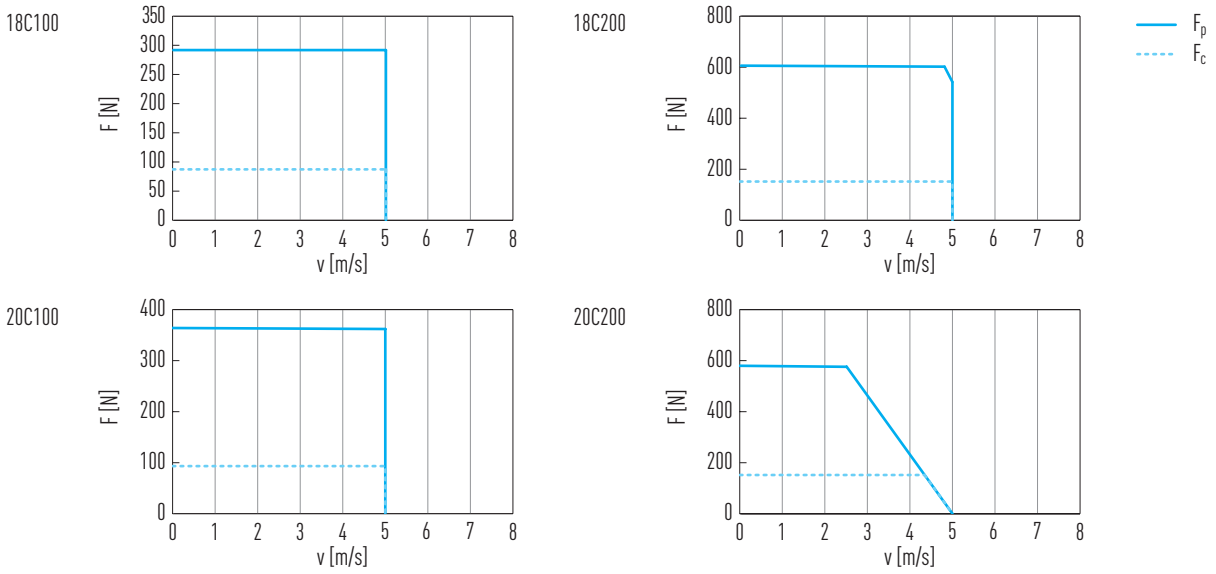

Acceleration as a function of load capacity (DC bus voltage: 325 VDC)

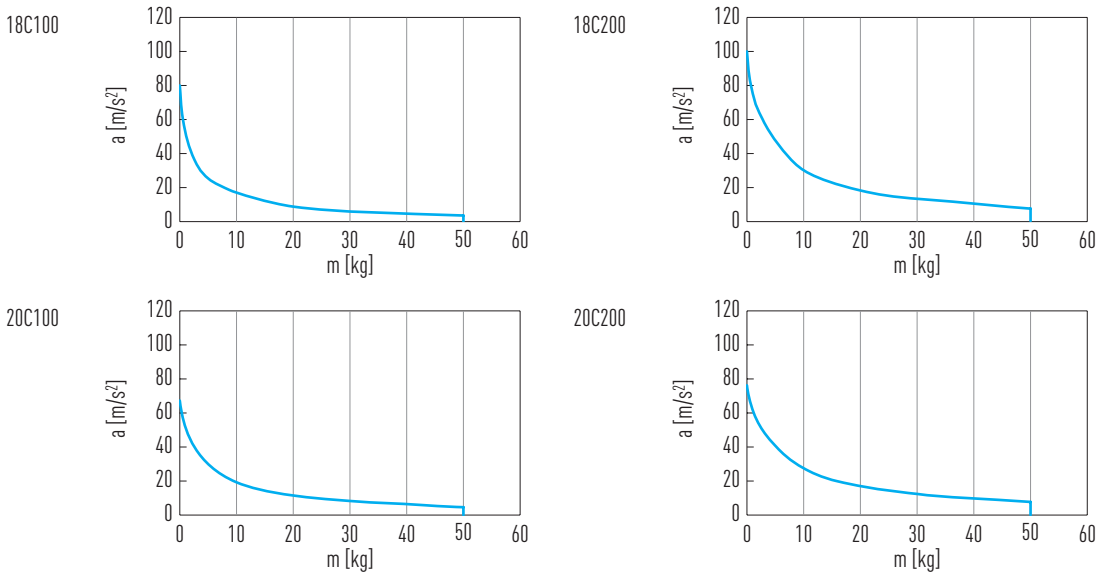

3.3.3 Technical data LMSSA-S (iron-core)

Table 3.1 Technical data LMSSA-S (iron-core) – sizes 08/10/13

	Symbol	Unit	08S050	08S100	10S100	10S200	13S100	13S200	13S300
Linear motor			LMSA01	LMSA02	LMSA11	LMSA12	LMSA11	LMSA12	LMSA13
Continuous force at T_{max}	F_c	N	52	104	103	205	103	205	308
Continuous current at T_{max}	I_c	A_{eff}	2.1	4.2	2.1	4.2	2.1	4.2	6.3
Peak force (for 1 s)	F_p	N	112	224	289	579	289	579	868
Peak current (for 1 s)	I_p	A_{eff}	6.3	12.6	6.3	12.7	6.3	12.7	19.0
Ultimate force (for 0.5 s)	F_u	N	192	384	379	759	379	759	1,138
Ultimate current (for 0.5 s)	I_u	A_{eff}	10.6	21.1	10.6	21.1	10.6	21.1	31.7
Force constant	K_f	N/A_{eff}	24.5		48.6				
Electrical time constant	K_e	ms	3.0	3.7	4.4	4.5	4.4	4.5	4.4
Resistance¹⁾	R_{25}	Ω	6.2	3.1	8.4	4.1	8.4	4.1	2.8
Inductance¹⁾	L	mH	19.0	11.6	37.1	18.5	37.1	18.5	12.4
Back EMF constant	K_u	$V_{eff}/(m/s)$	14.2		28.1				
Motor constant	K_m	N/\sqrt{W}	8.1	11.5	13.7	19.6	13.7	19.6	23.7
Thermal resistance	R_{th}	$^{\circ}C/W$	1.69	0.83	1.23	0.63	1.23	0.63	0.41
Thermal time constant	T_{th}	s	431	431	610	890	610	890	2,290
Thermal switch			1 × (3 PTC SNM 120 in series)						
Max. DC bus voltage		V	600						
Pole pair pitch	2τ	mm	30						
Max. winding temperature	T_{max}	$^{\circ}C$	120						
Repeatability		μm	Type A/K/P: ± 1 ; Type G: ± 2 ; Type D/E: ± 3						
Absolute accuracy		μm	Type A/K/P: ± 2 ; Type G: ± 4 ; Type D/E: ± 6						
Horizontal straightness		μm	$\pm 8/300$ mm						
Vertical straightness		μm	$\pm 8/300$ mm						
Max. speed		m/s	5						
Max. acceleration		m/s^2	50						
Moved mass		kg	1.8	3.0	2.1	3.4	3.4	5.2	7.5
Stroke length		mm	100 – 1,300 (in 50 mm increments), 1,400 – 2,700 (in 100 mm increments)						

¹⁾ Line to line

All specifications are in $\pm 10\%$ of tolerance at $25^{\circ}C$ ambient temperature

Linear Motor Systems

Linear motor axis LMSSA

3.3.4 Technical data LMSSA-S (iron-core)

	Symbol	Unit	18S100	18S200	18S300	20S300	20S500	20S700
Linear motor			LMSA11	LMSA12	LMSA13	LMSA22	LMSA23	LMSA24
Continuous force at T_{max}	F_c	N	103	205	308	362	544	725
Continuous current at T_{max}	I_c	A_{eff}	2.1	4.2	6.3	3.9	5.9	7.8
Peak force (for 1 s)	F_p	N	289	579	868	1,023	1,535	2,048
Peak current (for 1 s)	I_p	A_{eff}	6.3	12.7	19.0	11.8	17.6	23.5
Ultimate force (for 0.5 s)	F_u	N	379	759	1,138	1,341	2,011	2,682
Ultimate current (for 0.5 s)	I_u	A_{eff}	10.6	21.1	31.7	19.6	29.4	39.2
Force constant	K_f	N/A_{eff}	48.6			92.5		
Electrical time constant	K_e	ms	4.4	4.5	4.4	4.9	4.9	4.6
Resistance¹⁾	R_{25}	Ω	8.4	4.1	2.8	6.8	4.6	3.5
Inductance¹⁾	L	mH	37.1	18.5	12.4	33.0	22.4	16.0
Back EMF constant	K_u	$V_{eff}/(m/s)$	28.1			53.4		
Motor constant	K_m	N/\sqrt{W}	13.7	19.6	23.7	28.9	35.2	40.6
Thermal resistance	R_{th}	$^{\circ}C/W$	1.23	0.63	0.41	0.44	0.29	0.22
Thermal time constant	T_{th}	s	610	890	2,290	2,540	2,670	3,270
Thermal switch			1× (3 PTC SNM 120 in series)					
Max. DC bus voltage		V	600					
Pole pair pitch	2τ	mm	30					
Max. winding temperature	T_{max}	$^{\circ}C$	120					
Repeatability		μm	Type A/K: ± 1 ; Type D/E/G/P: ± 3					
Absolute accuracy		μm	Type A/K: ± 2 ; Type D/E/G/P: ± 6					
Horizontal straightness		μm	$\pm 8/300$ mm					
Vertical straightness		μm	$\pm 8/300$ mm					
Max. speed		m/s	5.0					
Max. acceleration		m/s^2	70	95	100			
Moved mass		kg	3.1	4.4	6.2	6.4	8.3	11.0
Stroke length		mm	200 – 1,300 (in 50 mm increments), 1,400 – 2,700 (in 100 mm increments)					

¹⁾ Line to line

All specifications are in $\pm 10\%$ of tolerance at 25 $^{\circ}C$ ambient temperature

3.3.5 Technical data LMSSA-C (coreless)

Table 3.3 Technical data LMSSA-C (coreless)

	Symbol	Unit	18C100	18C200	20C100	20C200
Linear motor			LMC-EFC2	LMC-EFC4	LMC-B5	LMC-B8
Continuous force at T_{max}	F_c	N	75	150	91	145
Continuous current at T_{max}	I_c	A_{eff}	3.4	3.4	2.0	2.0
Peak force (for 1 s)	F_p	N	300	600	364	580
Peak current (for 1 s)	I_p	A_{eff}	13.6	13.6	8.0	8.0
Force constant	K_f	N/A_{eff}	22.3	44.6	45.4	72.5
Electrical time constant	K_e	ms	0.7	0.7	0.4	0.3
Resistance¹⁾	R_{25}	Ω	3.3	6.3	9.0	14.6
Inductance¹⁾	L	mH	2.3	4.5	3.17	4.95
Back EMF constant	K_u	$V_{eff}/(m/s)$	12.9	25.8	24.8	40.0
Motor constant	K_m	N/\sqrt{W}	9.9	14.4	12.4	15.5
Thermal resistance	R_{th}	$^{\circ}C/W$	1.26	0.66	1.11	0.68
Thermal switch			3 PTC 120 $^{\circ}C$		3 PTC 100 $^{\circ}C$	
Max. DC bus voltage		VDC	330			
Pole pair pitch	2τ	mm	60		32	
Max. winding temperature	T_{max}	$^{\circ}C$	120		100	
Repeatability		μm	Type A/K: ± 1 ; Type D/E/G/P: ± 3			
Absolute accuracy		μm	Type A/K: ± 2 ; Type D/E/G/P: ± 6			
Horizontal straightness		μm	$\pm 8 / 300$ mm			
Vertical straightness		μm	$\pm 8 / 300$ mm			
Max. speed		m/s	5.0			
Max. acceleration		m/s^2	100			
Moved mass		kg	3.0	5.0	4.2	6.0
Stroke length		mm	200 – 1,300 (in 50 mm increments), 1,300 – 2,700 (in 100 increments)			

¹⁾ Line to line

All specifications are in $\pm 10\%$ of tolerance at 25 $^{\circ}C$ ambient temperature

Linear Motor Systems

Linear motor axis LMSSA

LMSSA-08 dimensions, single forcer

LMSSA-08S050, stroke length 100 – 1,400 mm

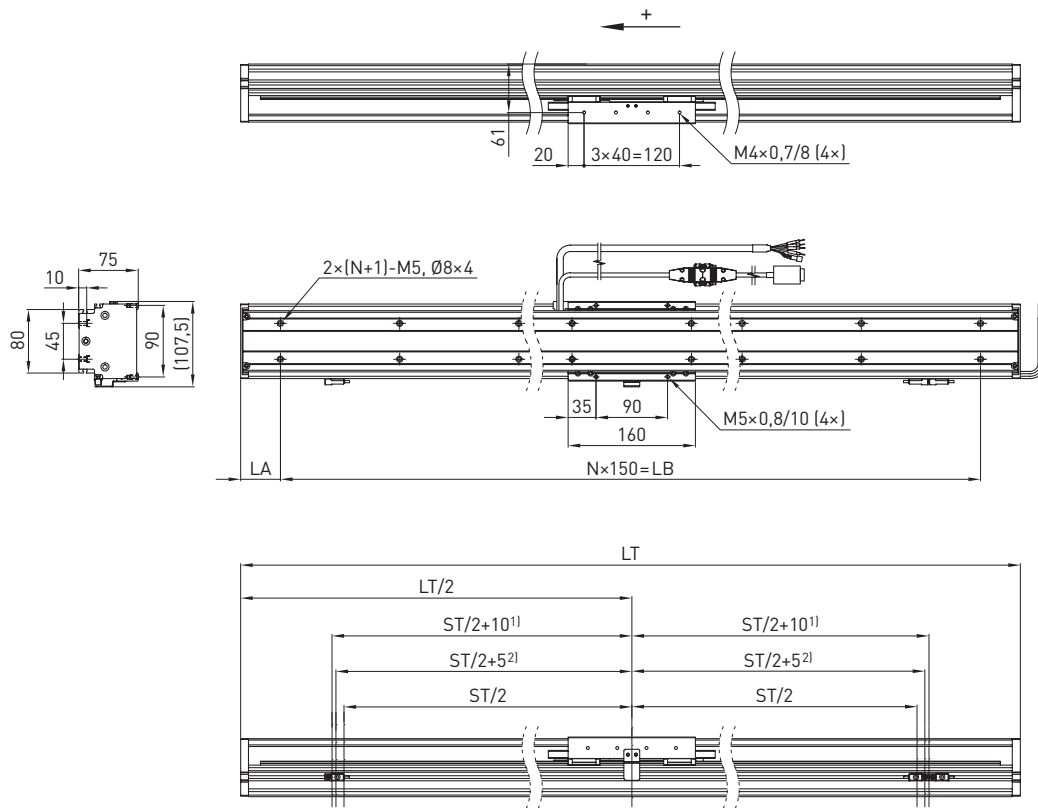

¹⁾ Stopping buffer position

²⁾ Limit switch position

All values in mm

Table 3.4 LMSSA-08S050 dimensions, single forcer, stroke length 100 – 700 mm

Stroke length ST	100	150	200	250	300	350	400	450	500	550	600	650	700
Total length LT	350	400	450	500	550	600	650	700	750	800	850	900	950
N	2	2	2	3	3	3	4	4	4	5	5	5	6
LA	25	50	75	25	50	75	25	50	75	25	50	75	25
LB	300	300	300	450	450	450	600	600	600	750	750	750	900
Stage weight [kg]	6.3	6.8	7.2	7.6	8.0	8.5	8.8	9.2	9.6	10.0	10.5	10.9	11.2

Table 3.5 LMSSA-08S050 dimensions, single forcer, stroke length 750 – 1,400 mm

Stroke length ST	750	800	850	900	950	1,000	1,050	1,100	1,150	1,200	1,250	1,300	1,400
Total length LT	1,000	1,050	1,100	1,150	1,200	1,250	1,300	1,350	1,400	1,450	1,500	1,550	1,650
N	6	6	7	7	7	8	8	8	9	9	9	10	10
LA	50	75	25	50	75	25	50	75	25	50	75	25	75
LB	900	900	1,050	1,050	1,050	1,200	1,200	1,200	1,350	1,350	1,350	1,500	1,500
Stage weight [kg]	11.6	12.1	12.5	12.9	13.3	13.6	14.1	14.5	14.9	15.3	15.8	16.1	16.9

LMSSA-08 dimensions, dual forcers

LMSSA-08S050, stroke length 100 – 1,200 mm

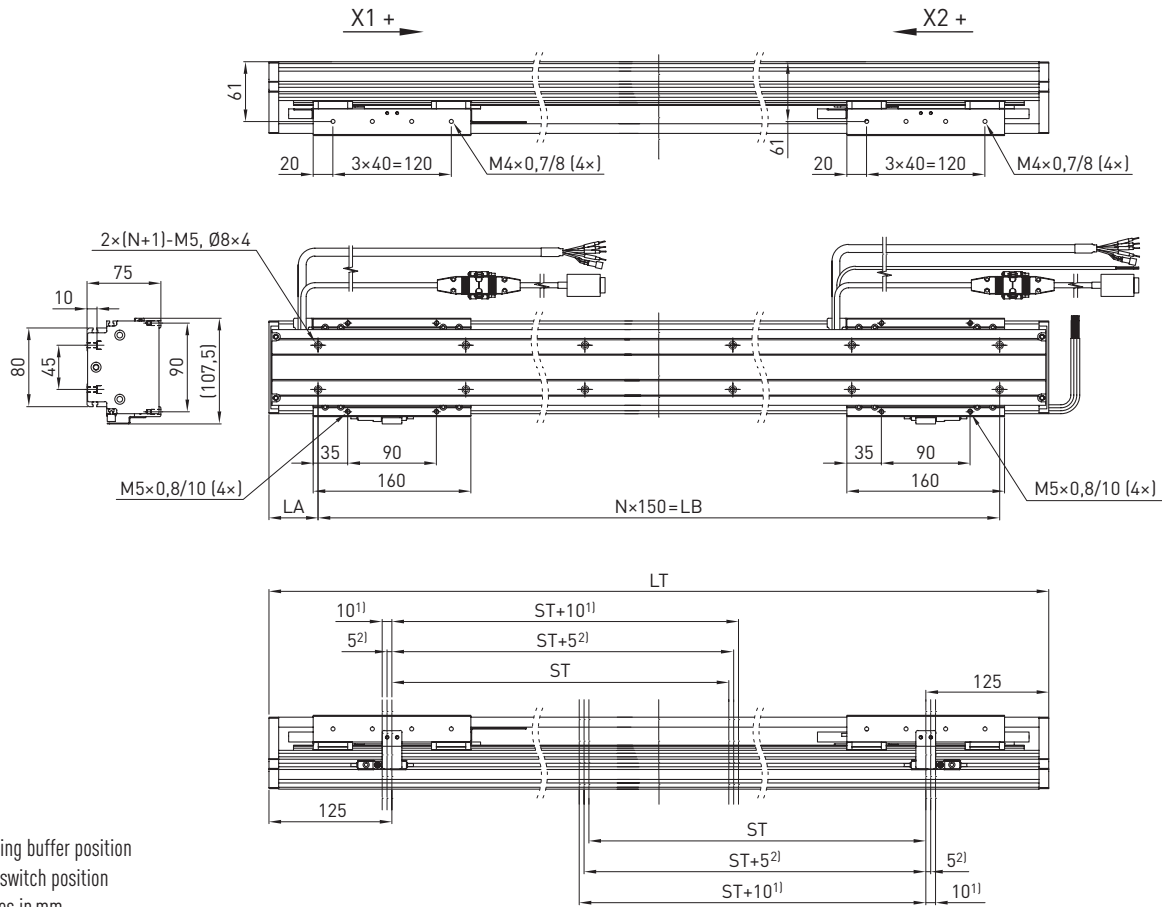

¹⁾ Stopping buffer position
²⁾ Limit switch position
All values in mm

Table 3.6 LMSSA-08S050 dimensions, dual forcers, stroke length 100 – 700 mm

Stroke length ST	100	150	200	250	300	350	400	450	500	550	600	650	700
Total length LT	550	600	650	700	750	800	850	900	950	1,000	1,050	1,100	1,150
N	3	3	4	4	4	5	5	5	6	6	6	7	7
LA	50	75	25	50	75	25	50	75	25	50	75	25	50
LB	450	450	600	600	600	750	750	750	900	900	900	1,050	1,050
Stage weight [kg]	9.2	9.6	10.0	10.5	10.9	11.3	11.6	12.1	12.5	12.9	13.3	13.8	14.1

Table 3.7 LMSSA-08S050 dimensions, dual forcers, stroke length 750 – 1,200 mm

Stroke length ST	750	800	850	900	950	1,000	1,050	1,100	1,150	1,200
Total length LT	1,200	1,250	1,300	1,350	1,400	1,450	1,500	1,550	1,600	1,650
N	7	8	8	8	9	9	9	10	10	10
LA	75	25	50	75	25	50	75	25	50	75
LB	1,050	1,200	1,200	1,200	1,350	1,350	1,350	1,500	1,500	1,500
Stage weight [kg]	14.5	14.9	15.3	15.8	16.2	16.5	16.9	17.4	17.8	18.2

Linear Motor Systems

Linear motor axis LMSSA

LMSSA-08 dimensions, single forcer

LMSSA-08S100, stroke length 100 – 1,300 mm

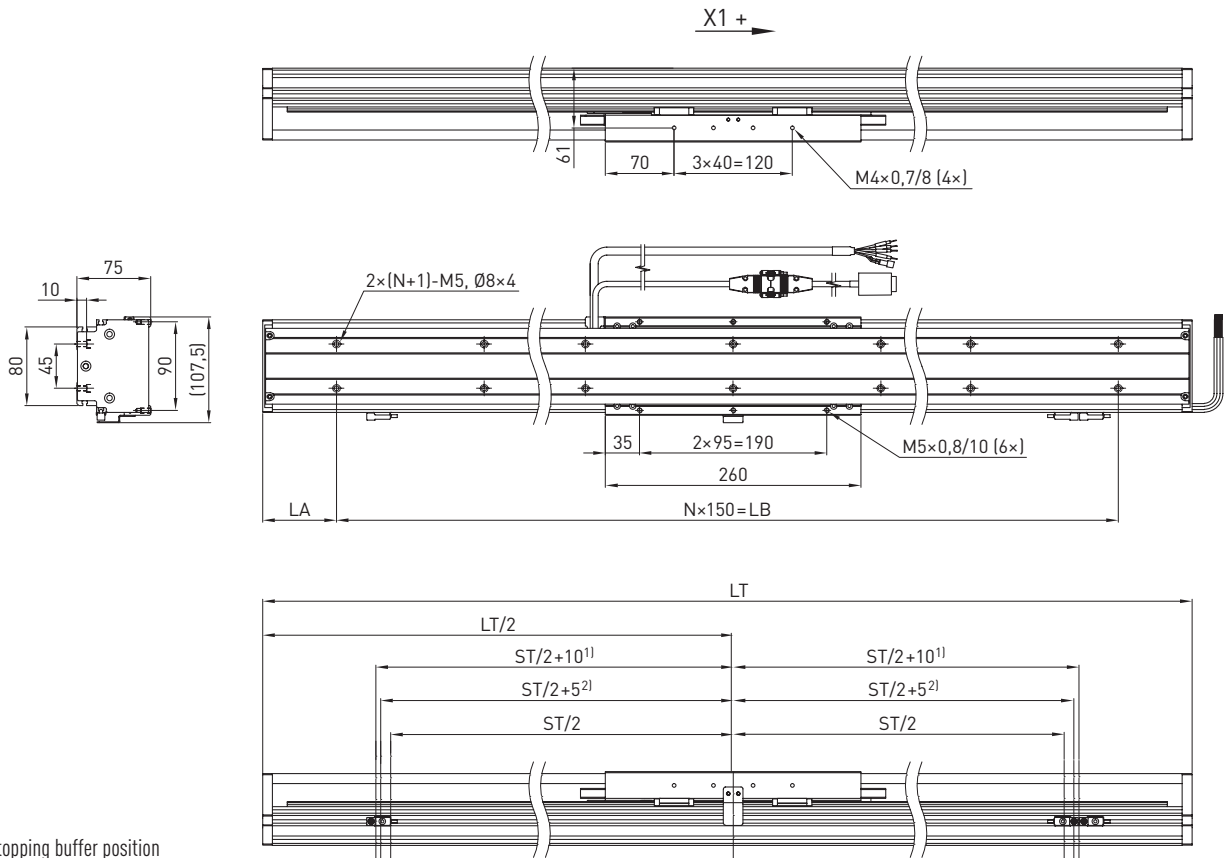

¹⁾ Stopping buffer position
²⁾ Limit switch position
 All values in mm

Table 3.8 LMSSA-08S100 dimensions, single forcer, stroke length 100 – 700 mm

Stroke length ST	100	150	200	250	300	350	400	450	500	550	600	650	700
Total length LT	450	500	550	600	650	700	750	800	850	900	950	1,000	1,050
N	2	3	3	3	4	4	4	5	5	5	6	6	6
LA	75	25	50	75	25	50	75	25	50	75	25	50	75
LB	300	450	450	450	600	600	600	750	750	750	900	900	900
Stage weight [kg]	8.1	8.5	8.9	9.4	9.8	10.1	10.5	10.9	11.4	11.8	12.2	12.5	13.0

Table 3.9 LMSSA-08S100 dimensions, single forcer, stroke length 750 – 1,300 mm

Stroke length ST	750	800	850	900	950	1,000	1,050	1,100	1,150	1,200	1,250	1,300
Total length LT	1,100	1,150	1,200	1,250	1,300	1,350	1,400	1,450	1,500	1,550	1,600	1,650
N	7	7	7	8	8	8	9	9	9	10	10	10
LA	25	50	75	25	50	75	25	50	75	25	50	75
LB	1,050	1,050	1,050	1,200	1,200	1,200	1,350	1,350	1,350	1,500	1,500	1,500
Stage weight [kg]	13.4	13.8	14.2	14.7	15.0	15.4	15.8	16.2	16.7	17.1	17.4	17.8

LMSSA-08 dimensions, dual forcers

LMSSA-08S100, stroke length 100 – 1,000 mm

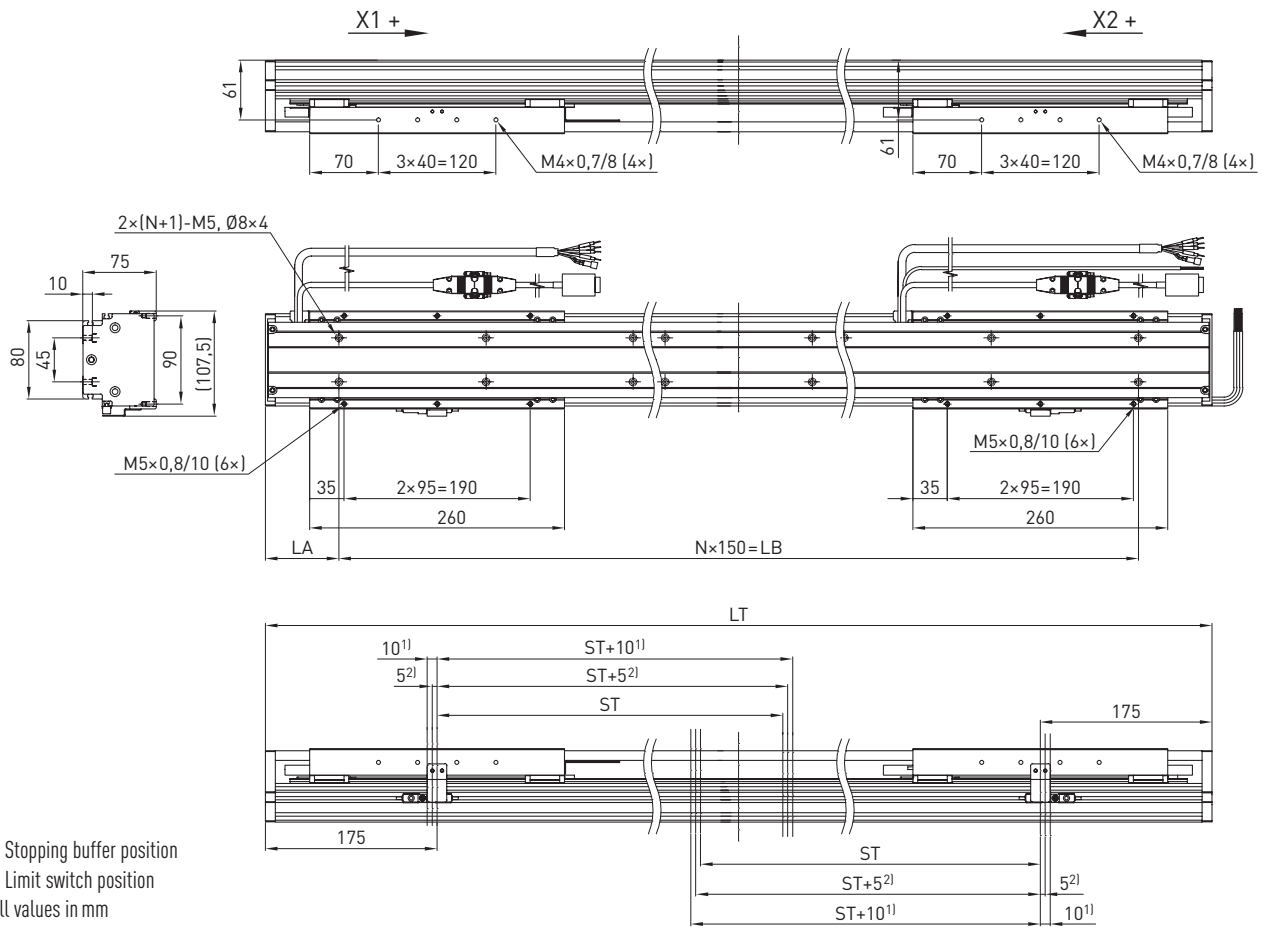

¹⁾ Stopping buffer position
²⁾ Limit switch position
All values in mm

Table 3.10 LMSSA-08S100 dimensions, dual forcers, stroke length 100 – 550 mm

Stroke length ST	100	150	200	250	300	350	400	450	500	550
Total length LT	750	800	850	900	950	1,000	1,050	1,100	1,150	1,200
N	4	5	5	5	6	6	6	7	7	7
LA	75	25	50	75	25	50	75	25	50	75
LB	600	750	750	750	900	900	900	1,050	1,050	1,050
Stage weight [kg]	12.5	12.9	13.3	13.7	14.0	14.5	14.9	15.3	15.8	16.2

Table 3.11 LMSSA-08S100 dimensions, dual forcers, stroke length 600 – 1,000 mm

Stroke length ST	600	650	700	750	800	850	900	950	1,000
Total length LT	1,250	1,300	1,350	1,400	1,450	1,500	1,550	1,600	1,650
N	8	8	8	9	9	9	10	10	10
LA	25	50	75	25	50	75	25	50	75
LB	1,200	1,200	1,200	1,350	1,350	1,350	1,500	1,500	1,500
Stage weight [kg]	16.5	16.9	17.3	17.8	18.2	18.6	18.9	19.3	19.8

Linear Motor Systems

Linear motor axis LMSSA

LMSSA-10 dimensions, single forcer

LMSSA-10S100, stroke length 100 – 1,400 mm

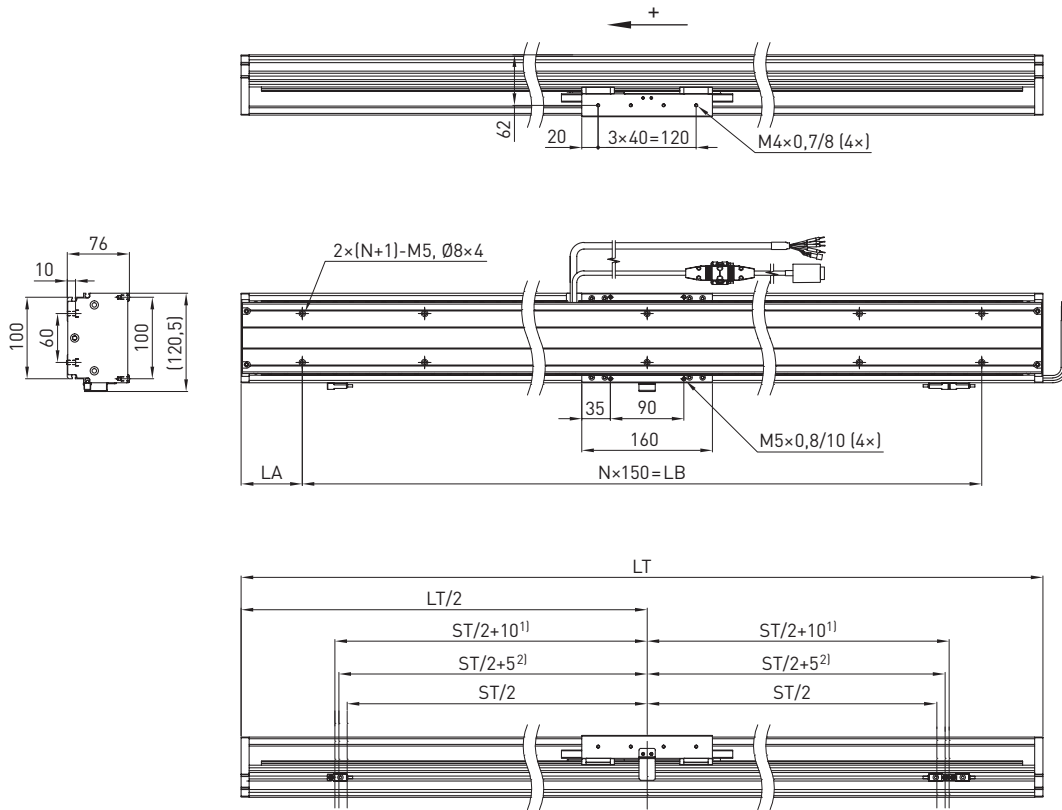

¹⁾ Stopping buffer position
²⁾ Limit switch position
 All values in mm

Table 3.12 LMSSA-10S100 dimensions, single forcer, stroke length 100 – 700 mm

Stroke length ST	100	150	200	250	300	350	400	450	500	550	600	650	700
Total length LT	350	400	450	500	550	600	650	700	750	800	850	900	950
N	2	2	2	3	3	3	4	4	4	5	5	5	6
LA	25	50	75	25	50	75	25	50	75	25	50	75	25
LB	300	300	300	450	450	450	600	600	600	750	750	750	900
Stage weight [kg]	7.4	7.9	8.5	8.8	9.3	9.9	10.4	10.9	11.5	11.8	12.3	12.9	13.4

Table 3.13 LMSSA-10S100 dimensions, single forcer, stroke length 750 – 1.400 mm

Stroke length ST	750	800	850	900	950	1,000	1,050	1,100	1,150	1,200	1,250	1,300	1,400
Total length LT	1,000	1,050	1,100	1,150	1,200	1,250	1,300	1,350	1,400	1,450	1,500	1,550	1,650
N	6	6	7	7	7	8	8	8	9	9	9	10	10
LA	50	75	25	50	75	25	50	75	25	50	75	25	75
LB	900	900	1,050	1,050	1,050	1,200	1,200	1,200	1,350	1,350	1,350	1,500	1,500
Stage weight [kg]	13.9	14.5	14.8	15.3	15.9	16.4	16.9	17.5	17.8	18.3	18.9	19.4	20.5

LMSSA-10 dimensions, dual forcers

LMSSA-10S100, stroke length 100 – 1,200 mm

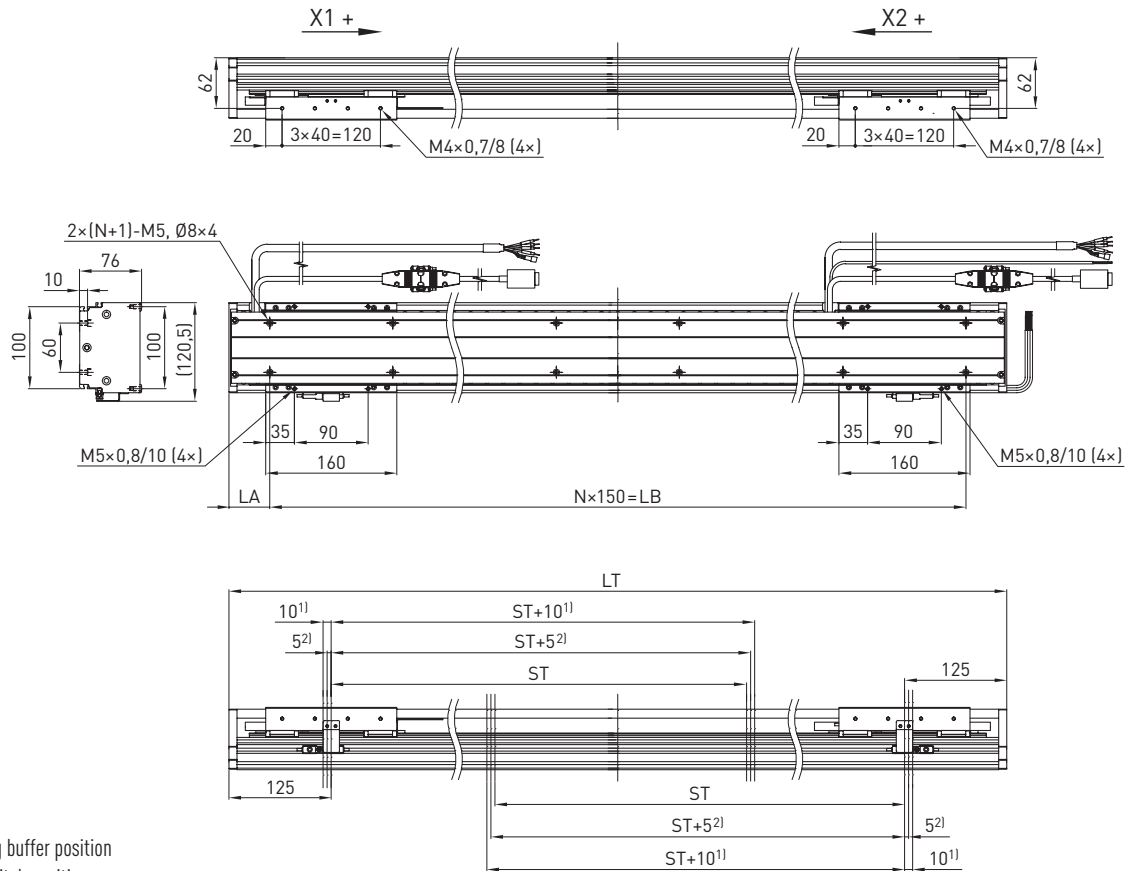

¹⁾ Stopping buffer position
²⁾ Limit switch position
All values in mm

Table 3.14 LMSSA-10S100 dimensions, dual forcers, stroke length 100 – 700 mm

Stroke length ST	100	150	200	250	300	350	400	450	500	550	600	650	700
Total length LT	350	400	450	500	550	600	650	700	750	800	850	900	950
N	2	2	2	3	3	3	4	4	4	5	5	5	6
LA	25	50	75	25	50	75	25	50	75	25	50	75	25
LB	300	300	300	450	450	450	600	600	600	750	750	750	900
Stage weight [kg]	7.4	7.9	8.5	8.8	9.3	9.9	10.4	10.9	11.5	11.8	12.3	12.9	13.4

Table 3.15 LMSSA-10S100 dimensions, dual forcers, stroke length 750 – 1,400 mm

Stroke length ST	750	800	850	900	950	1,000	1,050	1,100	1,150	1,200	1,250	1,300	1,400
Total length LT	1,000	1,050	1,100	1,150	1,200	1,250	1,300	1,350	1,400	1,450	1,500	1,550	1,650
N	6	6	7	7	7	8	8	8	9	9	9	10	10
LA	50	75	25	50	75	25	50	75	25	50	75	25	75
LB	900	900	1,050	1,050	1,050	1,200	1,200	1,200	1,350	1,350	1,350	1,500	1,500
Stage weight [kg]	13.9	14.5	14.8	15.3	15.9	16.4	16.9	17.5	17.8	18.3	18.9	19.4	20.5

Linear Motor Systems

Linear motor axis LMSSA

LMSSA-10 dimensions, single forcer

LMSSA-10S200, stroke length 100 – 1,300 mm

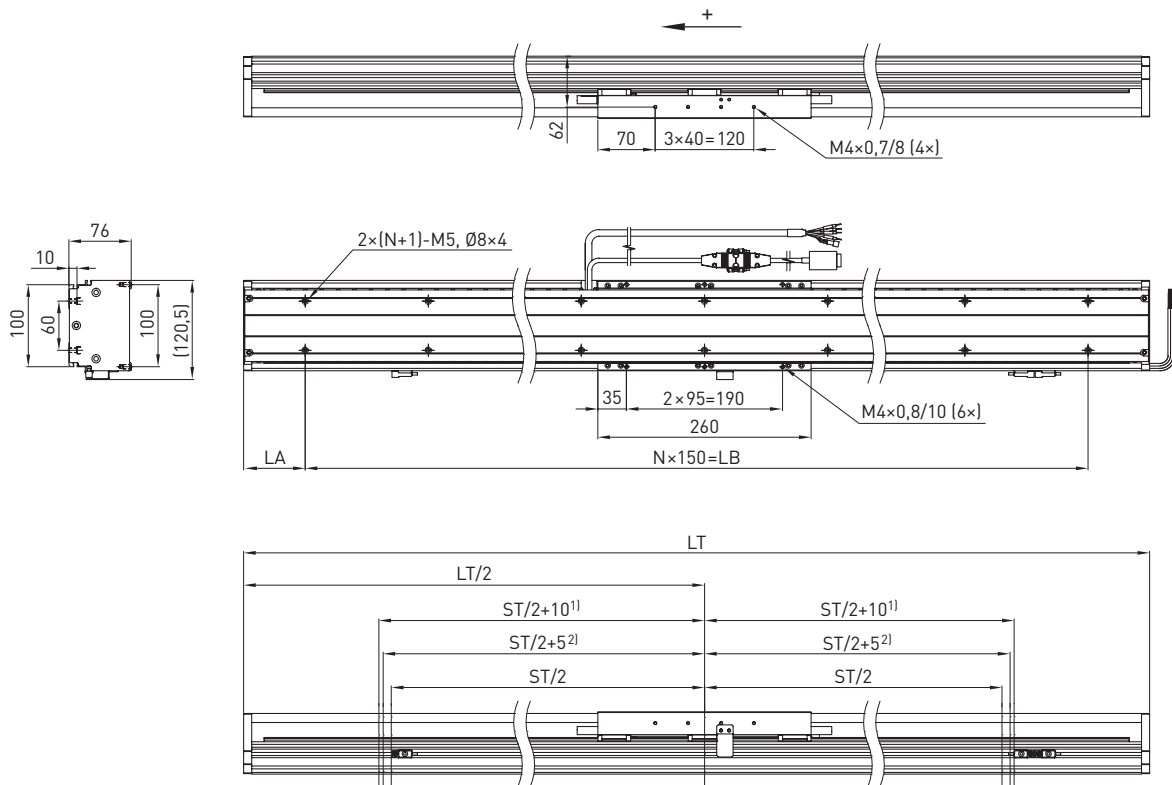

¹⁾ Stopping buffer position

²⁾ Limit switch position

All values in mm

Table 3.16 LMSSA-10S200 dimensions, single forcer, stroke length 100 – 700 mm

Stroke length ST	100	150	200	250	300	350	400	450	500	550	600	650	700
Total length LT	450	500	550	600	650	700	750	800	850	900	950	1,000	1,050
N	2	3	3	3	4	4	4	5	5	5	6	6	6
LA	75	25	50	75	25	50	75	25	50	75	25	50	75
LB	300	450	450	450	600	600	600	750	750	750	900	900	900
Stage weight [kg]	9.6	10.1	10.5	11.0	11.5	12.0	12.6	13.1	13.4	14.0	14.5	15.0	15.6

Table 3.17 LMSSA-10S200 dimensions, single forcer, stroke length 750 – 1.300 mm

Stroke length ST	750	800	850	900	950	1,000	1,050	1,100	1,150	1,200	1,250	1,300
Total length LT	1,100	1,150	1,200	1,250	1,300	1,350	1,400	1,450	1,500	1,550	1,600	1,650
N	7	7	7	8	8	8	9	9	9	10	10	10
LA	25	50	75	25	50	75	25	50	75	25	50	75
LB	1,050	1,050	1,050	1,200	1,200	1,200	1,350	1,350	1,350	1,500	1,500	1,500
Stage weight [kg]	16.1	16.4	17.0	17.5	18.0	18.6	19.1	19.4	20.0	20.5	21.0	21.6

LMSSA-10 dimensions, dual forcers

LMSSA-10S200, stroke length 100 – 1,000 mm

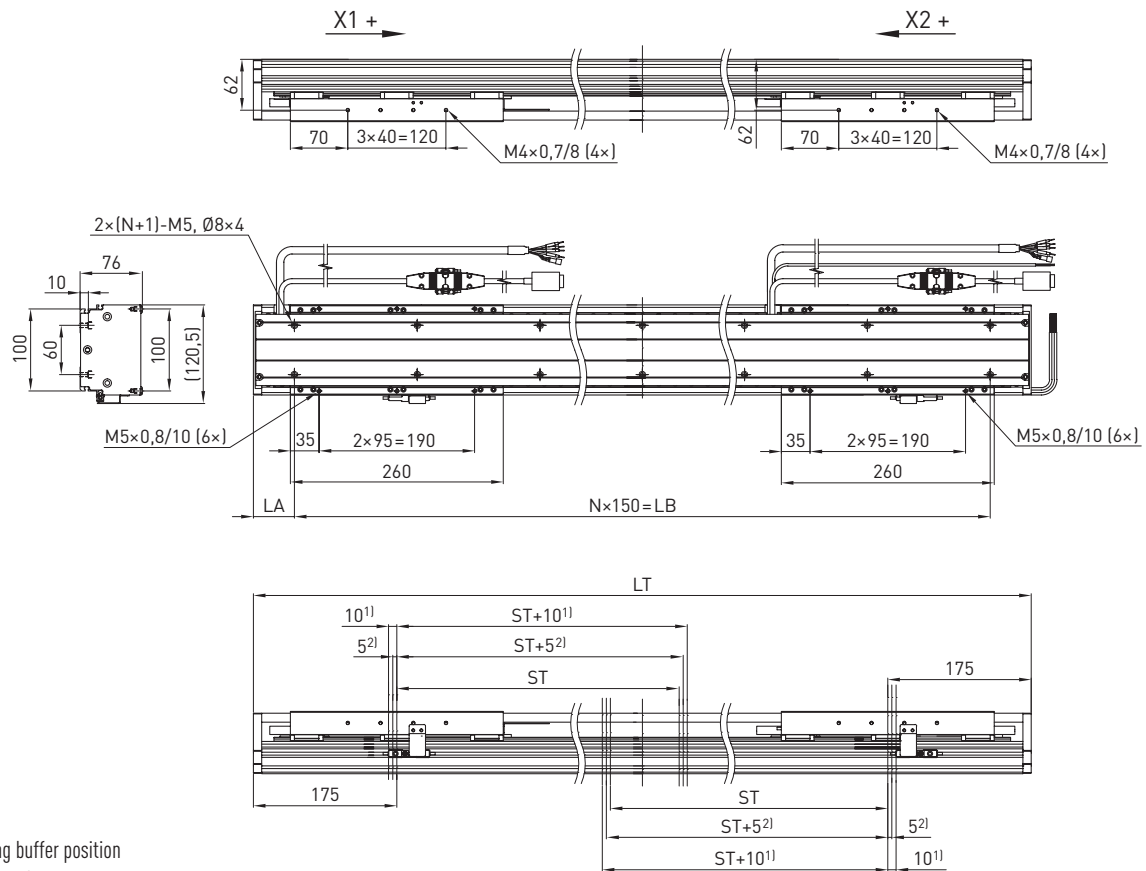

¹⁾ Stopping buffer position
²⁾ Limit switch position
All values in mm

Table 3.18 LMSSA-10S200 dimensions, dual forcers, stroke length 100 – 550 mm

Stroke length ST	100	150	200	250	300	350	400	450	500	550
Total length LT	750	800	850	900	950	1,000	1,050	1,100	1,150	1,200
N	4	5	5	5	6	6	6	7	7	7
LA	75	25	50	75	25	50	75	25	50	75
LB	600	750	750	750	900	900	900	1,050	1,050	1,050
Stage weight [kg]	14.9	15.5	16.0	16.5	17.0	17.4	17.9	18.5	19.0	19.5

Table 3.19 LMSSA-10S200 dimensions, dual forcers, stroke length 600 – 1.000 mm

Stroke length ST	600	650	700	750	800	850	900	950	1,000
Total length LT	1,250	1,300	1,350	1,400	1,450	1,500	1,550	1,600	1,650
N	8	8	8	9	9	9	10	10	10
LA	25	50	75	25	50	75	25	50	75
LB	1,200	1,200	1,200	1,350	1,350	1,350	1,500	1,500	1,500
Stage weight [kg]	20.0	20.4	20.9	21.5	22.0	22.5	23.0	23.4	23.9

Linear Motor Systems

Linear motor axis LMSSA

LMSSA-13 dimensions, single forcer

LMSSA-13S100, stroke length 100 – 2,700 mm

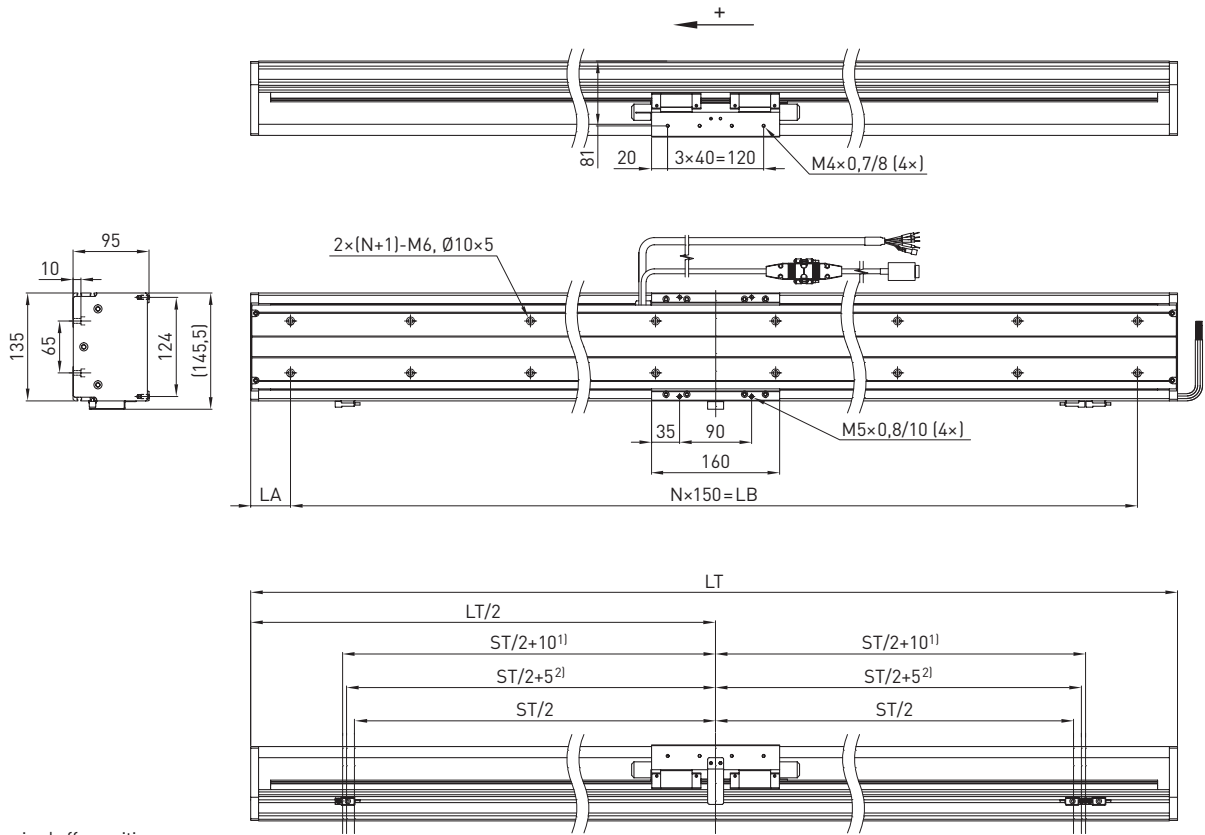

¹⁾ Stopping buffer position
²⁾ Limit switch position
 All values in mm

Table 3.20 LMSSA-13S100 dimensions, single forcer, stroke length 100 – 1,100 mm

Stroke length ST	100	150	200	250	300	350	400	450	500	550	600	650	700	750	800	850	900	950	1,000	1,050	1,100
Total length LT	350	400	450	500	550	600	650	700	750	800	850	900	950	1,000	1,050	1,100	1,150	1,200	1,250	1,300	1,350
N	2	2	2	3	3	3	4	4	4	5	5	5	6	6	6	7	7	7	8	8	8
LA	25	50	75	25	50	75	25	50	75	25	50	75	25	50	75	25	50	75	25	50	75
LB	300	300	300	450	450	450	600	600	600	750	750	750	900	900	900	1,050	1,050	1,050	1,200	1,200	1,200
Stage weight [kg]	10.6	11.4	12.2	12.9	13.7	14.5	15.3	16.1	16.9	17.6	18.4	19.2	20.0	20.9	21.7	22.3	23.1	24.0	24.8	25.6	26.4

Table 3.21 LMSSA-13S100 dimensions, single forcer, stroke length 1,150 – 2,700 mm

Stroke length ST	1,150	1,200	1,250	1,300	1,400	1,500	1,600	1,700	1,800	1,900	2,000	2,100	2,200	2,300	2,400	2,500	2,600	2,700
Total length LT	1,400	1,450	1,500	1,550	1,650	1,750	1,850	1,950	2,050	2,150	2,250	2,350	2,450	2,550	2,650	2,750	2,850	2,950
N	9	9	9	10	10	11	12	12	13	14	14	15	16	16	17	18	18	19
LA	25	50	75	25	50	75	25	50	75	25	75	25	75	25	50	75	25	50
LB	1,350	1,350	1,350	1,500	1,500	1,650	1,800	1,800	1,950	2,100	2,100	2,250	2,400	2,400	2,550	2,700	2,700	2,850
Stage weight [kg]	27.1	27.9	28.7	29.5	31.3	32.6	34.2	35.9	37.3	39.0	40.6	42.1	43.7	45.3	46.8	48.4	50.1	51.5

LMSSA-13 dimensions, dual forcers

LMSSA-13S100, stroke length 100 – 2,500 mm

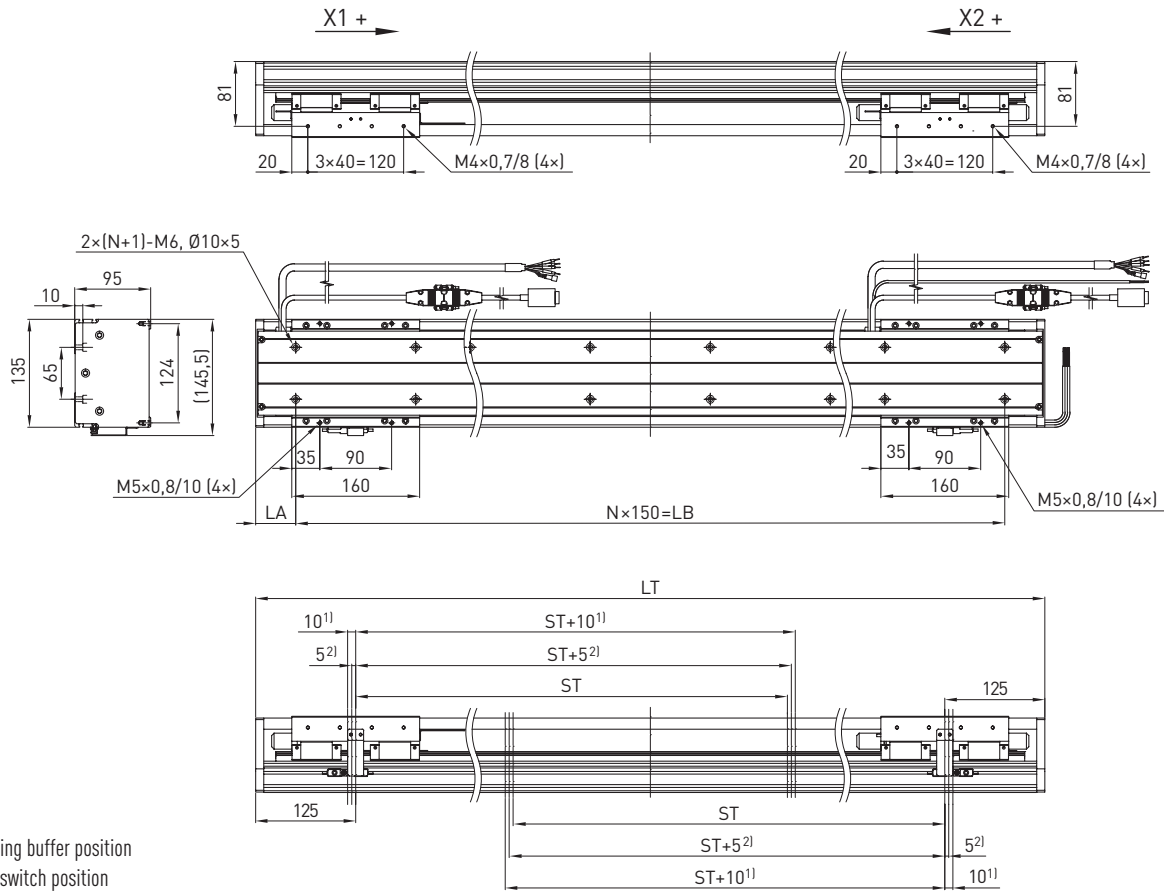

¹⁾ Stopping buffer position
²⁾ Limit switch position
All values in mm

Table 3.22 LMSSA-13S100 dimensions, dual forcers, stroke length 100 – 1,050 mm

Stroke length ST	100	150	200	250	300	350	400	450	500	550	600	650	700	750	800	850	900	950	1,000	1,050
Total length LT	550	600	650	700	750	800	850	900	950	1,000	1,050	1,100	1,150	1,200	1,250	1,300	1,350	1,400	1,450	1,500
N	3	3	4	4	4	5	5	5	6	6	6	7	7	7	8	8	8	9	9	9
LA	50	75	25	50	75	25	50	75	25	50	75	25	50	75	25	50	75	25	50	75
LB	450	450	600	600	600	750	750	750	900	900	900	1,050	1,050	1,050	1,200	1,200	1,200	1,350	1,350	1,350
Stage weight [kg]	16.1	16.9	17.8	18.4	19.2	20.0	20.9	21.7	22.5	23.1	24.0	24.8	25.6	26.4	27.2	27.9	28.7	29.5	30.3	31.1

Table 3.23 LMSSA-13S100 dimensions, dual forcers, stroke length 1,100 – 2,500 mm

Stroke length ST	1,100	1,150	1,200	1,250	1,300	1,400	1,500	1,600	1,700	1,800	1,900	2,000	2,100	2,200	2,300	2,400	2,500
Total length LT	1,550	1,600	1,650	1,700	1,750	1,850	1,950	2,050	2,150	2,250	2,350	2,450	2,550	2,650	2,750	2,850	2,950
N	10	10	10	11	11	12	12	13	14	14	15	16	16	17	18	18	19
LA	25	50	75	25	50	75	25	50	75	25	75	25	75	25	50	75	50
LB	1,500	1,500	1,500	1,650	1,650	1,800	1,800	1,950	2,100	2,100	2,250	2,400	2,400	2,550	2,700	2,700	2,850
Stage weight [kg]	32.0	32.6	33.4	34.2	35.1	36.7	38.2	39.8	41.4	42.9	44.5	46.2	47.6	49.3	50.9	52.4	54.0

Linear Motor Systems

Linear motor axis LMSSA

LMSSA-13 dimensions, single forcer

LMSSA-13S200, stroke length 100 – 2,600 mm

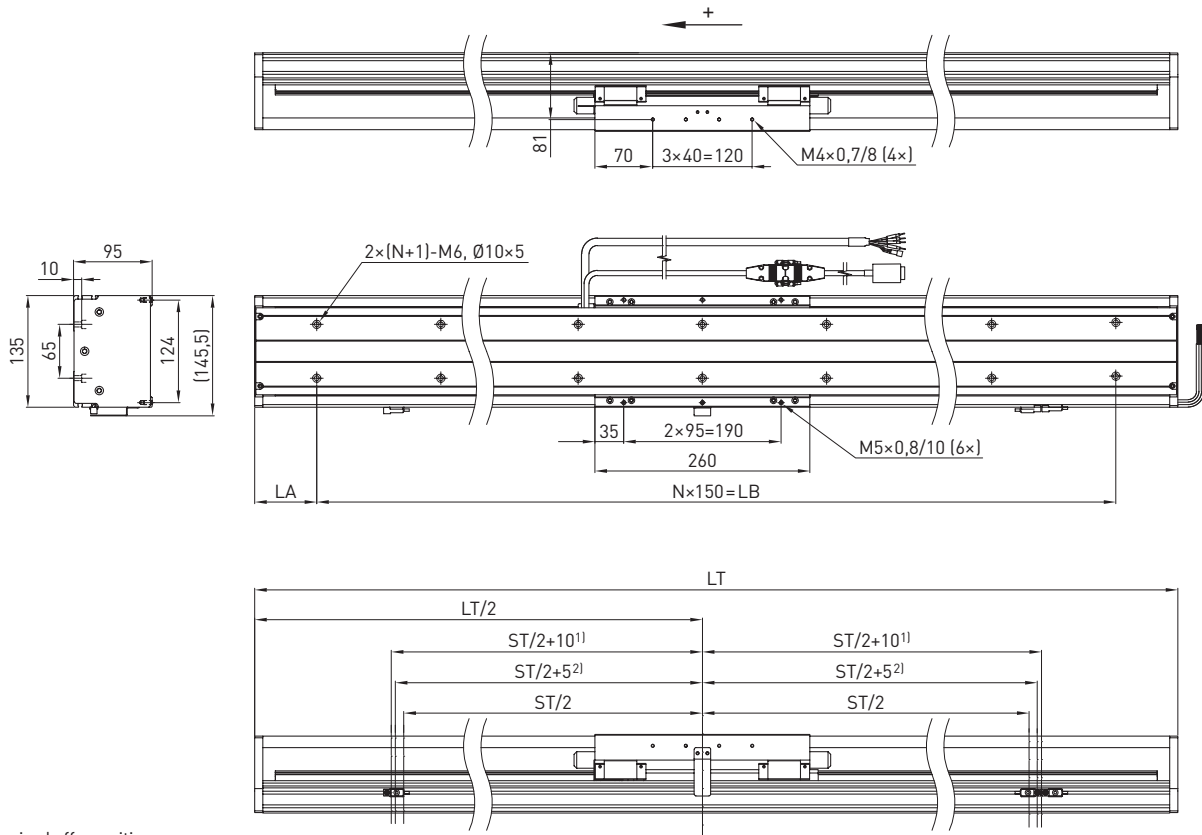

1) Stopping buffer position
 2) Limit switch position
 All values in mm

Table 3.24 LMSSA-13S200 dimensions, single forcer, stroke length 100 – 1,050 mm

Stroke length ST	100	150	200	250	300	350	400	450	500	550	600	650	700	750	800	850	900	950	1,000	1,050
Total length LT	450	500	550	600	650	700	750	800	850	900	950	1,000	1,050	1,100	1,150	1,200	1,250	1,300	1,350	1,400
N	2	3	3	3	4	4	4	5	5	5	6	6	6	7	7	7	8	8	8	9
LA	75	25	50	75	25	50	75	25	50	75	25	50	75	25	50	75	25	50	75	25
LB	300	450	450	450	600	600	600	750	750	750	900	900	900	1,050	1,050	1,050	1,200	1,200	1,200	1,350
Stage weight [kg]	13.5	14.3	15.0	15.8	16.6	17.4	18.3	19.1	19.7	20.5	21.4	22.2	23.0	23.8	24.5	25.3	26.1	26.9	27.7	28.5

Table 3.25 LMSSA-13S200 dimensions, single forcer, stroke length 1,100 – 2,600 mm

Stroke length ST	1,100	1,150	1,200	1,250	1,300	1,400	1,500	1,600	1,700	1,800	1,900	2,000	2,100	2,200	2,300	2,400	2,500	2,600
Total length LT	1,450	1,500	1,550	1,600	1,650	1,750	1,850	1,950	2,050	2,150	2,250	2,350	2,450	2,550	2,650	2,750	2,850	2,950
N	9	9	10	10	10	11	12	12	13	14	14	15	16	16	17	18	18	19
LA	50	75	25	50	75	50	25	75	50	25	75	50	25	75	50	25	75	50
LB	1,350	1,350	1,500	1,500	1,500	1,650	1,800	1,800	1,950	2,100	2,100	2,250	2,400	2,400	2,550	2,700	2,700	2,850
Stage weight [kg]	29.2	30.0	30.8	31.6	32.4	33.9	35.5	37.2	38.6	40.3	41.9	43.4	45.0	46.6	48.1	49.7	51.4	52.8

LMSSA-13 dimensions, dual forcers

LMSSA-13S200, stroke length 100 – 2,300 mm

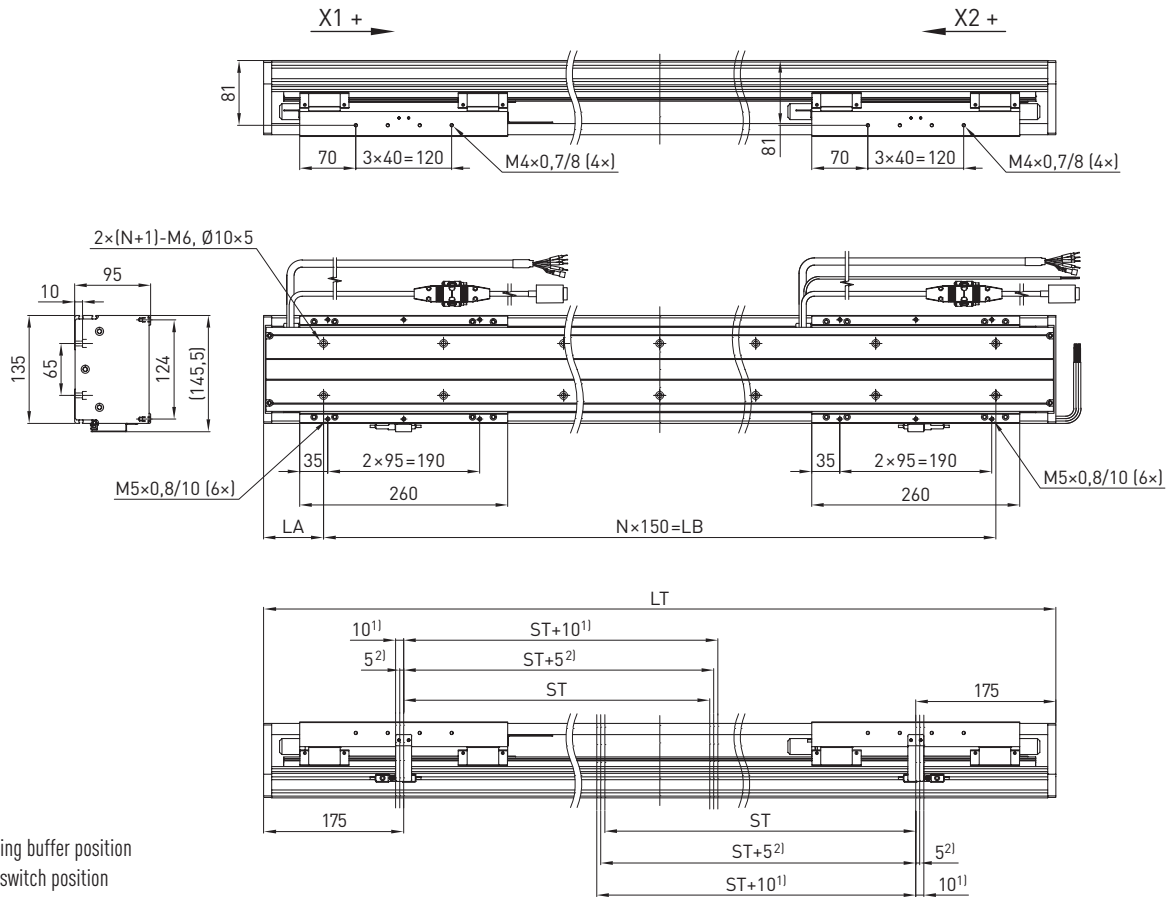

¹⁾ Stopping buffer position
²⁾ Limit switch position
All values in mm

Table 3.26 LMSSA-13S200 dimensions, dual forcers, stroke length 100 – 950 mm

Stroke length ST	100	150	200	250	300	350	400	450	500	550	600	650	700	750	800	850	900	950
Total length LT	750	800	850	900	950	1,000	1,050	1,100	1,150	1,200	1,250	1,300	1,350	1,400	1,450	1,500	1,550	1,600
N	4	5	5	5	6	6	6	7	7	7	8	8	8	9	9	9	10	10
LA	75	25	50	75	25	50	75	25	50	75	25	50	75	25	50	75	25	50
LB	600	750	750	750	900	900	900	1,050	1,050	1,050	1,200	1,200	1,200	1,350	1,350	1,350	1,500	1,500
Stage weight [kg]	21.8	22.6	23.5	24.3	25.1	25.7	26.6	27.4	28.2	29.0	29.8	30.5	31.3	32.1	32.9	33.7	34.6	35.2

Table 3.27 LMSSA-13S200 dimensions, dual forcers, stroke length 1,000 – 2,300 mm

Stroke length ST	1,000	1,050	1,100	1,150	1,200	1,250	1,300	1,400	1,500	1,600	1,700	1,800	1,900	2,000	2,100	2,200	2,300
Total length LT	1,650	1,700	1,750	1,800	1,850	1,900	1,950	2,050	2,150	2,250	2,350	2,450	2,550	2,650	2,750	2,850	2,950
N	10	11	11	11	12	12	12	13	14	14	15	16	16	17	18	18	19
LA	75	25	50	75	25	50	75	50	25	75	50	25	75	50	25	75	50
LB	1,500	1,650	1,650	1,650	1,800	1,800	1,800	1,950	2,100	2,100	2,250	2,400	2,400	2,550	2,700	2,700	2,850
Stage weight [kg]	36.0	36.8	37.7	38.5	39.3	40.1	41.1	42.7	44.2	45.8	47.4	48.9	50.6	52.2	53.7	55.3	56.9

Linear Motor Systems

Linear motor axis LMSSA

LMSSA-13 dimensions, single forcer

LMSSA-13S300, stroke length 100 – 2,500 mm

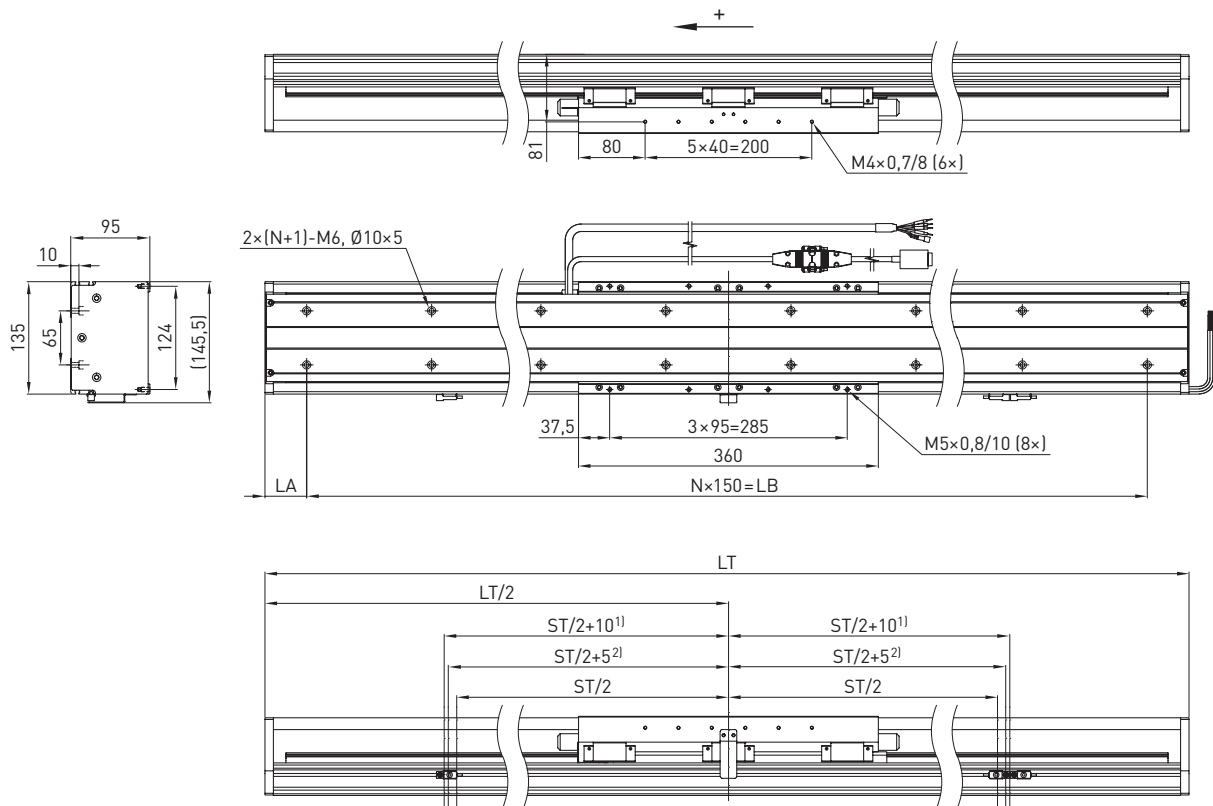

¹⁾ Stopping buffer position

²⁾ Limit switch position

All values in mm

Table 3.28 LMSSA-13S300 dimensions, single forcer, stroke length 100 – 1,000 mm

Stroke length ST	100	150	200	250	300	350	400	450	500	550	600	650	700	750	800	850	900	950	1,000
Total length LT	550	600	650	700	750	800	850	900	950	1,000	1,050	1,100	1,150	1,200	1,250	1,300	1,350	1,400	1,450
N	3	3	4	4	4	5	5	5	6	6	6	7	7	7	8	8	8	9	9
LA	50	75	25	50	75	25	50	75	25	50	75	25	50	75	25	50	75	25	50
LB	450	450	600	600	600	750	750	750	900	900	900	1,050	1,050	1,050	1,200	1,200	1,200	1,350	1,350
Stage weight [kg]	16.7	17.5	18.3	19.1	20.0	20.8	21.4	22.2	23.1	23.9	24.7	25.5	26.2	27.0	27.8	28.6	29.4	30.2	30.9

Table 3.29 LMSSA-13S300 dimensions, single forcer, stroke length 1,050 – 2,500 mm

Stroke length ST	1,050	1,100	1,150	1,200	1,250	1,300	1,400	1,500	1,600	1,700	1,800	1,900	2,000	2,100	2,200	2,300	2,400	2,500
Total length LT	1,500	1,550	1,600	1,650	1,700	1,750	1,850	1,950	2,050	2,150	2,250	2,350	2,450	2,550	2,650	2,750	2,850	2,950
N	9	10	10	10	11	11	12	12	13	14	14	15	16	16	17	18	18	19
LA	75	25	50	75	25	50	25	75	50	25	75	50	25	75	50	25	75	50
LB	1,350	1,500	1,500	1,500	1,650	1,650	1,800	1,800	1,950	2,100	2,100	2,250	2,400	2,400	2,550	2,700	2,700	2,850
Stage weight [kg]	31.7	32.5	33.3	34.1	35.0	35.6	37.2	38.9	40.3	42.0	43.6	45.1	46.7	48.3	49.8	51.4	53.1	54.5

LMSSA-13 dimensions, dual forcers

LMSSA-13S300, stroke length 100 – 2,100 mm

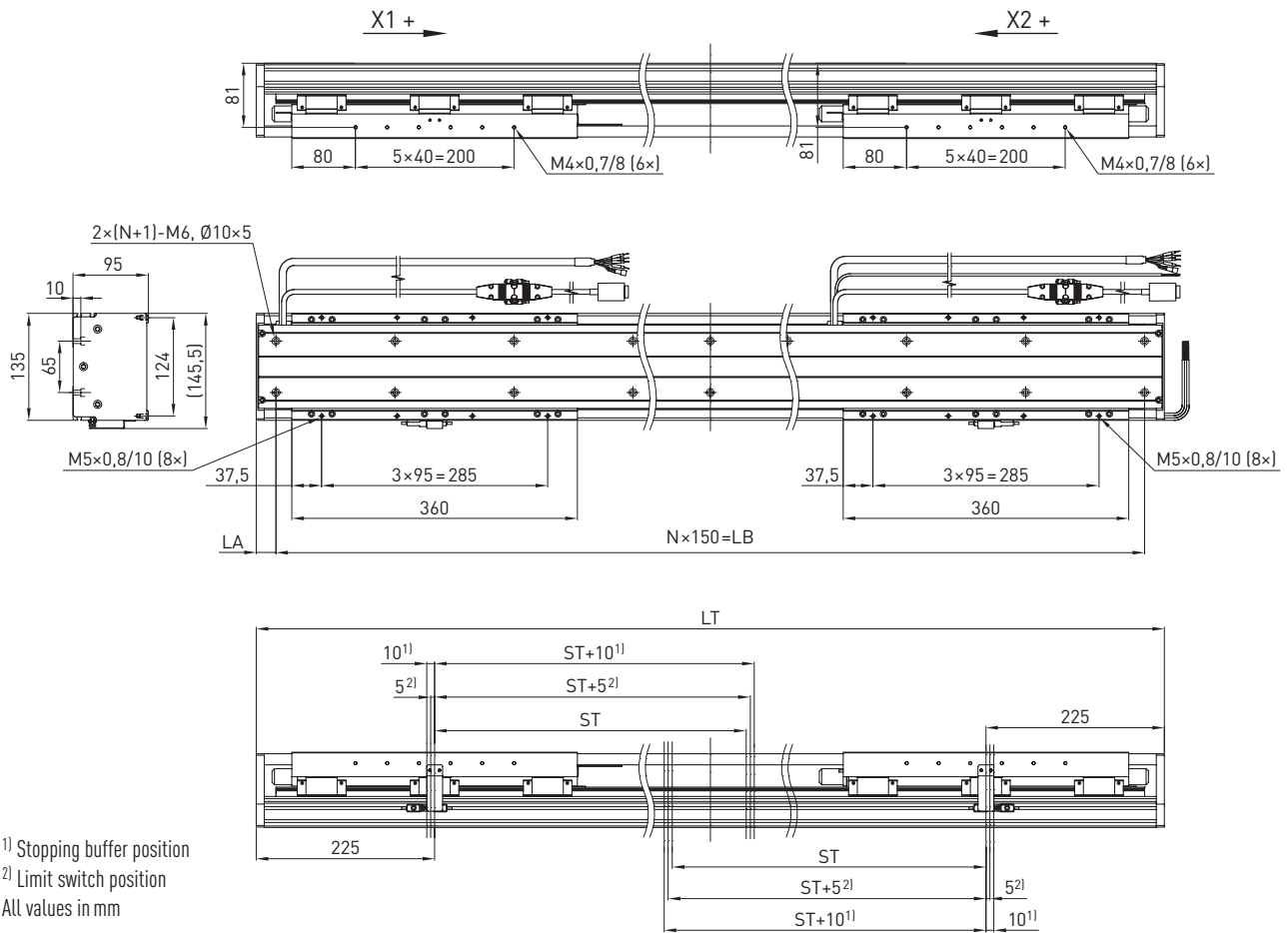

Table 3.30 LMSSA-13S300 dimensions, dual forcers, stroke length 100 – 900 mm

Stroke length ST	100	150	200	250	300	350	400	450	500	550	600	650	700	750	800	850	900
Total length LT	950	1,000	1,050	1,100	1,150	1,200	1,250	1,300	1,350	1,400	1,450	1,500	1,550	1,600	1,650	1,700	1,750
N	6	6	6	7	7	7	8	8	8	9	9	9	10	10	10	11	11
LA	25	50	75	25	50	75	25	50	75	25	50	75	25	50	75	25	50
LB	900	900	900	1,050	1,050	1,050	1,200	1,200	1,200	1,350	1,350	1,350	1,500	1,500	1,500	1,650	1,650
Stage weight [kg]	31.7	32.5	33.3	34.2	35.0	35.9	36.5	37.4	38.2	39.1	39.9	40.7	41.4	42.2	43.1	43.9	44.8

Table 3.31 LMSSA-13S300 dimensions, dual forcers, stroke length 950 – 2,100 mm

Stroke length ST	950	1,000	1,050	1,100	1,150	1,200	1,250	1,300	1,400	1,500	1,600	1,700	1,800	1,900	2,000	2,100
Total length LT	1,800	1,850	1,900	1,950	2,000	2,050	2,100	2,150	2,250	2,350	2,450	2,550	2,650	2,750	2,850	2,950
N	11	12	12	12	13	13	13	14	14	15	16	16	17	18	18	19
LA	75	25	50	75	25	50	75	25	75	50	25	75	50	25	75	50
LB	1,650	1,800	1,800	1,800	1,950	1,950	1,950	2,100	2,100	2,250	2,400	2,550	2,700	2,700	2,700	2,850
Stage weight [kg]	45.6	46.3	47.1	48.0	48.8	49.6	50.5	51.2	52.8	54.5	56.0	57.7	59.4	60.9	62.6	64.3

Linear Motor Systems

Linear motor axis LMSSA

LMSSA-18 dimensions, single forcer

LMSSA-18S100, LMSSA-18C100, stroke length 200 – 1,500 mm

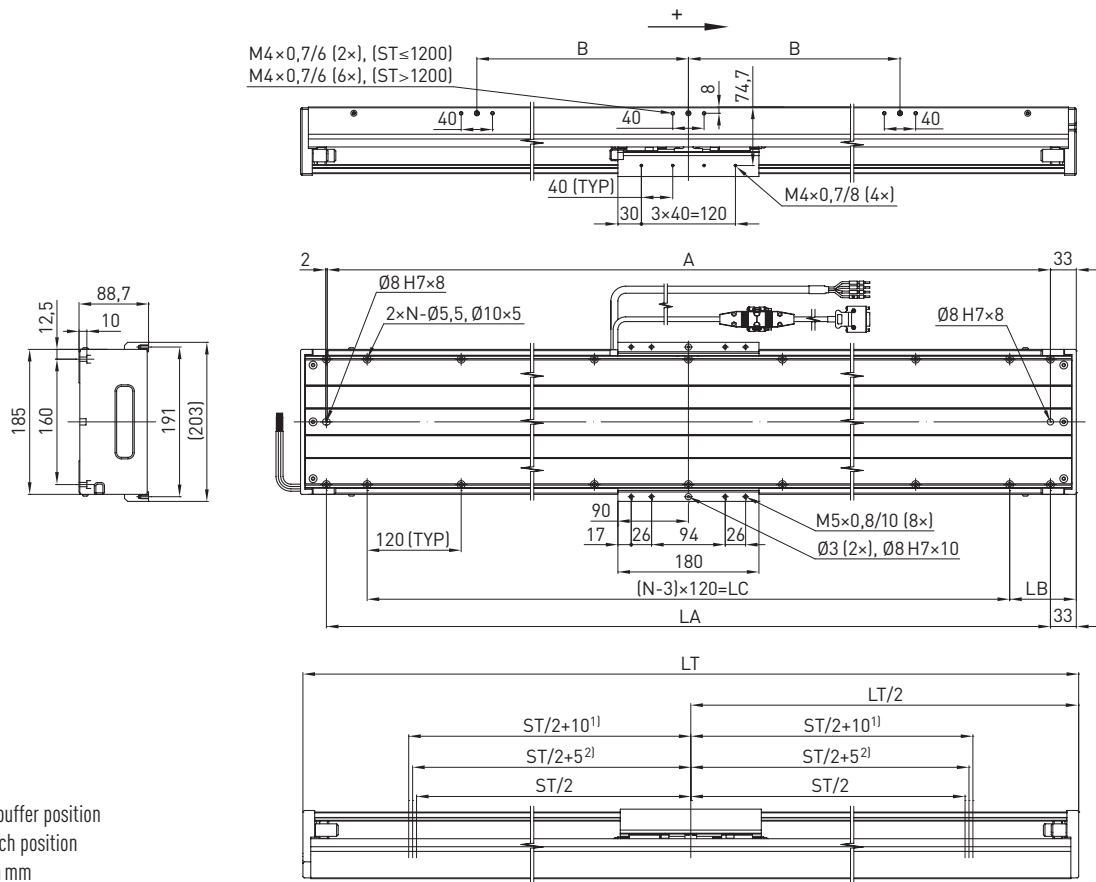

¹⁾ Stopping buffer position
²⁾ Limit switch position
 All values in mm

Table 3.32 LMSSA-18S100, -18C100 dimensions, single forcer, stroke length 200 – 800 mm

Stroke length ST [mm]	200	250	300	350	400	450	500	550	600	650	700	750	800	
Total length LT [mm]	490	540	590	640	690	740	790	840	890	940	990	1,040	1,090	
N [mm]	5	5	7	7	7	7	7	9	9	9	9	9	11	
LA [mm]	424	474	524	574	624	674	724	774	824	874	924	974	1,024	
LB [mm]	125	150	55	80	105	130	155	60	85	110	135	160	65	
LC [mm]	240	240	480	480	480	480	480	720	720	720	720	720	960	
A [mm]	423	473	523	573	623	673	723	773	823	873	923	973	1,023	
B [mm]	—	—	—	—	—	—	—	—	—	—	—	—	—	
Stage weight [kg]	18S100	12.0	12.9	13.8	14.7	15.6	16.5	17.4	18.3	19.2	20.1	21.0	21.9	22.8
	18C100	15.9	17.0	18.1	19.2	20.3	21.4	22.5	23.7	24.8	25.9	27.0	28.1	29.2

Table 3.33 LMSSA-18S100, -18C100 dimensions, single forcer, stroke length 850 – 1,500 mm

Stroke length ST [mm]	850	900	950	1,000	1,050	1,100	1,150	1,200	1,250	1,300	1,400	1,500	
Total length LT [mm]	1,140	1,190	1,240	1,290	1,340	1,390	1,440	1,490	1,540	1,590	1,690	1,790	
N [mm]	11	11	13	13	13	13	13	13	15	15	15	17	
LA [mm]	1,074	1,124	1,174	1,224	1,274	1,324	1,374	1,424	1,474	1,524	1,624	1,723	
LB [mm]	90	115	20	45	70	95	120	145	50	75	125	55	
LC [mm]	960	960	1,200	1,200	1,200	1,200	1,200	1,200	1,440	1,440	1,440	1,680	
A [mm]	1,073	1,123	1,173	1,223	1,273	1,323	1,373	1,423	1,473	1,523	1,623	1,723	
B [mm]	—	—	—	—	—	—	—	—	360	360	360	600	
Stage weight [kg]	18S100	23.7	24.6	25.5	26.4	27.3	28.2	29.1	30.0	30.9	31.8	33.6	35.4
	18C100	30.3	31.4	32.6	33.7	34.8	35.9	37.0	38.1	39.2	40.3	42.6	44.8

LMSSA-18 dimensions, dual forcers

LMSSA-18S100, LMSSA-18C100, stroke length 200 – 1,280 mm

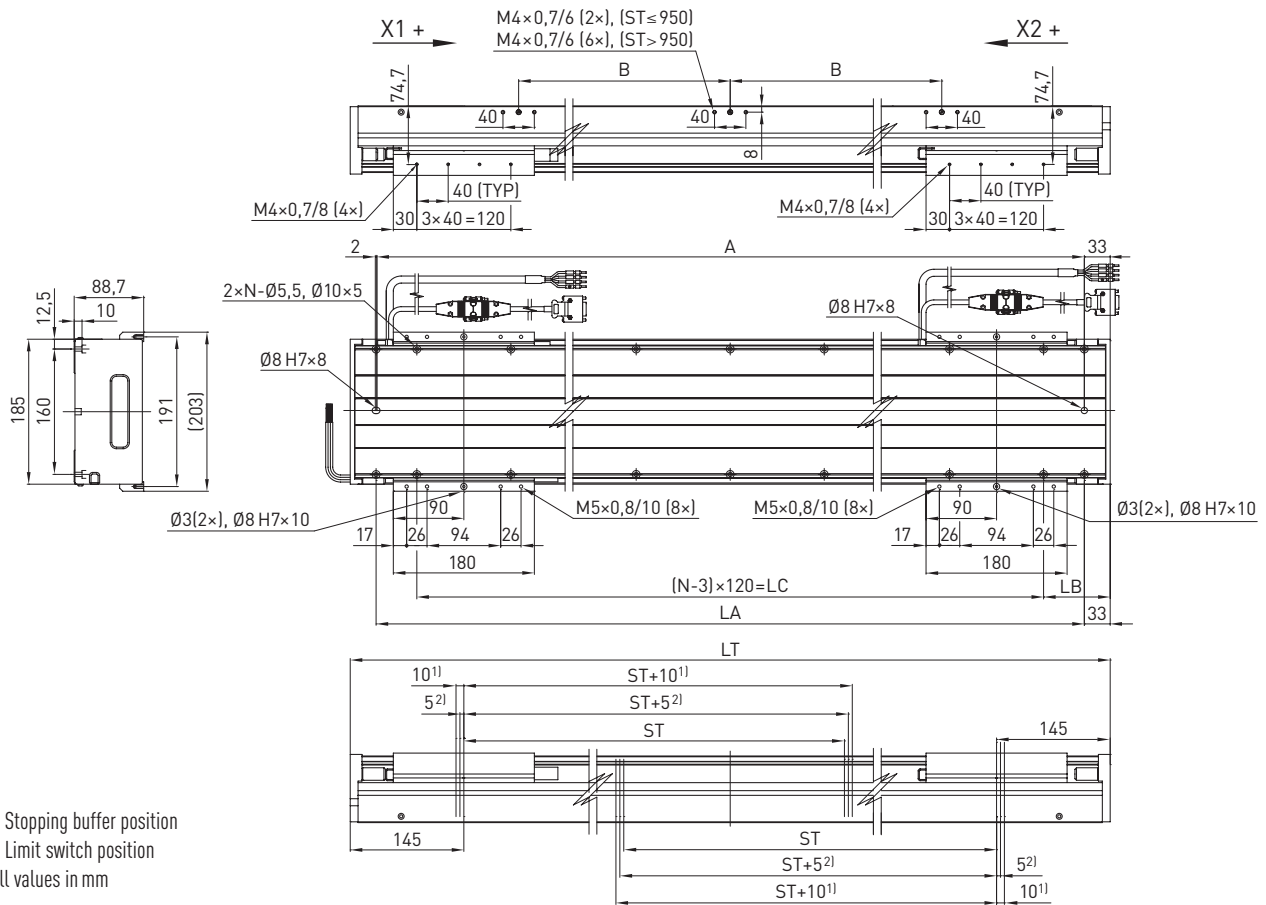

Table 3.34 LMSSA-18S100, -18C100 dimensions, dual forcers, stroke length 200 – 730 mm

Stroke length ST [mm]	230	280	330	380	430	480	530	580	630	680	730	
Total length LT [mm]	740	790	840	890	940	990	1,040	1,090	1,140	1,190	1,240	
N [mm]	7	7	9	9	9	9	9	11	11	11	13	
LA [mm]	674	724	774	824	874	924	974	1,024	1,074	1,124	1,174	
LB [mm]	130	155	60	85	110	135	160	65	90	115	20	
LC [mm]	480	480	720	720	720	720	720	960	960	960	1,200	
A [mm]	673	723	773	823	873	923	973	1,023	1,073	1,123	1,173	
B [mm]	—	—	—	—	—	—	—	—	—	—	—	
Stage weight [kg]	18S100	19.4	20.3	21.2	22.1	23.0	23.9	24.8	25.7	26.6	27.5	28.4
	18C100	24.1	25.2	26.3	27.5	28.6	29.7	30.8	31.9	33.0	34.1	35.2

Table 3.35 LMSSA-18S100, -18C100 dimensions, dual forcers, stroke length 780 – 1,280 mm

Stroke length ST [mm]	780	830	880	930	980	1,030	1,080	1,130	1,180	1,230	1,280	
Total length LT [mm]	1,290	1,340	1,390	1,440	1,490	1,540	1,590	1,640	1,690	1,740	1,790	
N [mm]	13	13	13	13	13	15	15	15	15	15	17	
LA [mm]	1,224	1,274	1,324	1,374	1,424	1,474	1,524	1,574	1,624	1,674	1,724	
LB [mm]	45	70	95	120	145	50	75	100	125	150	55	
LC [mm]	1,200	1,200	1,200	1,200	1,200	1,440	1,440	1,440	1,440	1,440	1,680	
A [mm]	1,223	1,273	1,323	1,373	1,423	1,473	1,523	1,573	1,623	1,673	1,723	
B [mm]	—	—	—	—	—	—	360	360	360	600	600	
Stage weight [kg]	18S100	29.3	30.2	31.1	32.0	32.9	33.8	34.7	35.6	36.5	37.4	38.3
	18C100	36.3	37.5	38.6	39.7	40.8	41.9	43.0	44.1	45.2	46.3	47.5

Linear Motor Systems

Linear motor axis LMSSA

LMSSA-18 dimensions, single forcer

LMSSA-18S100, LMSSA-18C100, stroke length 1,600 – 2,700 mm

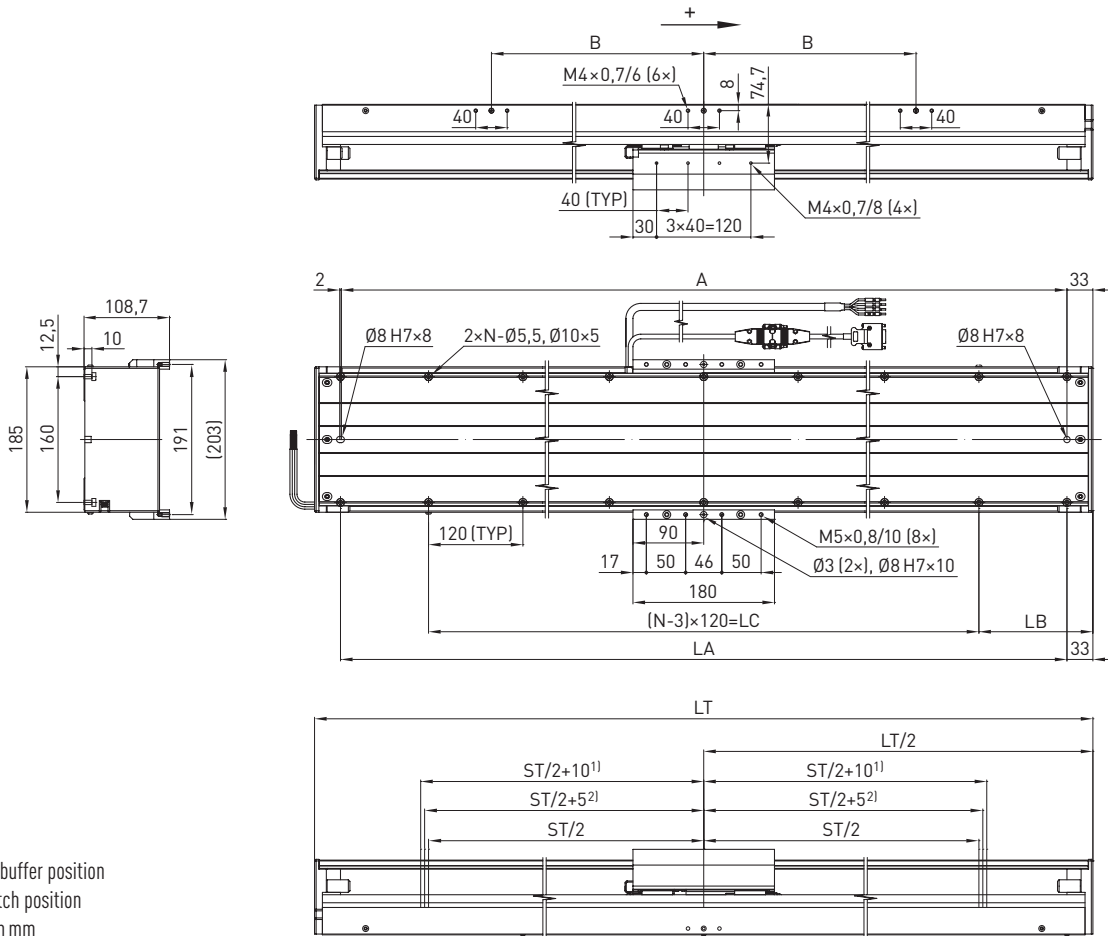

1) Stopping buffer position
 2) Limit switch position
 All values in mm

Table 3.36 LMSSA-18S100, -18C100 dimensions, single forcer, stroke length 1,600 – 2,700 mm

Stroke length ST [mm]	1,600	1,700	1,800	1,900	2,000	2,100	2,200	2,300	2,400	2,500	2,600	2,700
Total length LT [mm]	1,890	1,990	2,090	2,190	2,290	2,390	2,490	2,590	2,690	2,790	2,890	2,990
N [mm]	17	17	19	19	21	21	23	23	23	25	25	27
LA [mm]	1,824	1,924	2,024	2,124	2,224	2,324	2,424	2,524	2,624	2,724	2,824	2,924
LB [mm]	105	155	85	135	65	115	45	95	145	75	125	55
LC [mm]	1,680	1,680	1,920	1,920	2,160	2,160	2,400	2,400	2,400	2,640	2,640	2,880
A [mm]	1,823	1,923	2,023	2,123	2,223	2,323	2,423	2,523	2,623	2,723	2,823	2,923
B [mm]	600	600	600	840	840	840	840	840	1,080	1,080	1,080	1,080
Stage weight [kg]	18S100	38.4	40.2	42.0	43.8	45.6	47.4	49.2	51.0	52.7	54.5	56.3
	18C100	48.2	50.4	52.7	54.9	57.1	59.3	61.5	63.8	66.0	68.2	70.4

LMSSA-18 dimensions, dual forcers

LMSSA-18S100, LMSSA-18C100, stroke length 1,330 – 2,430 mm

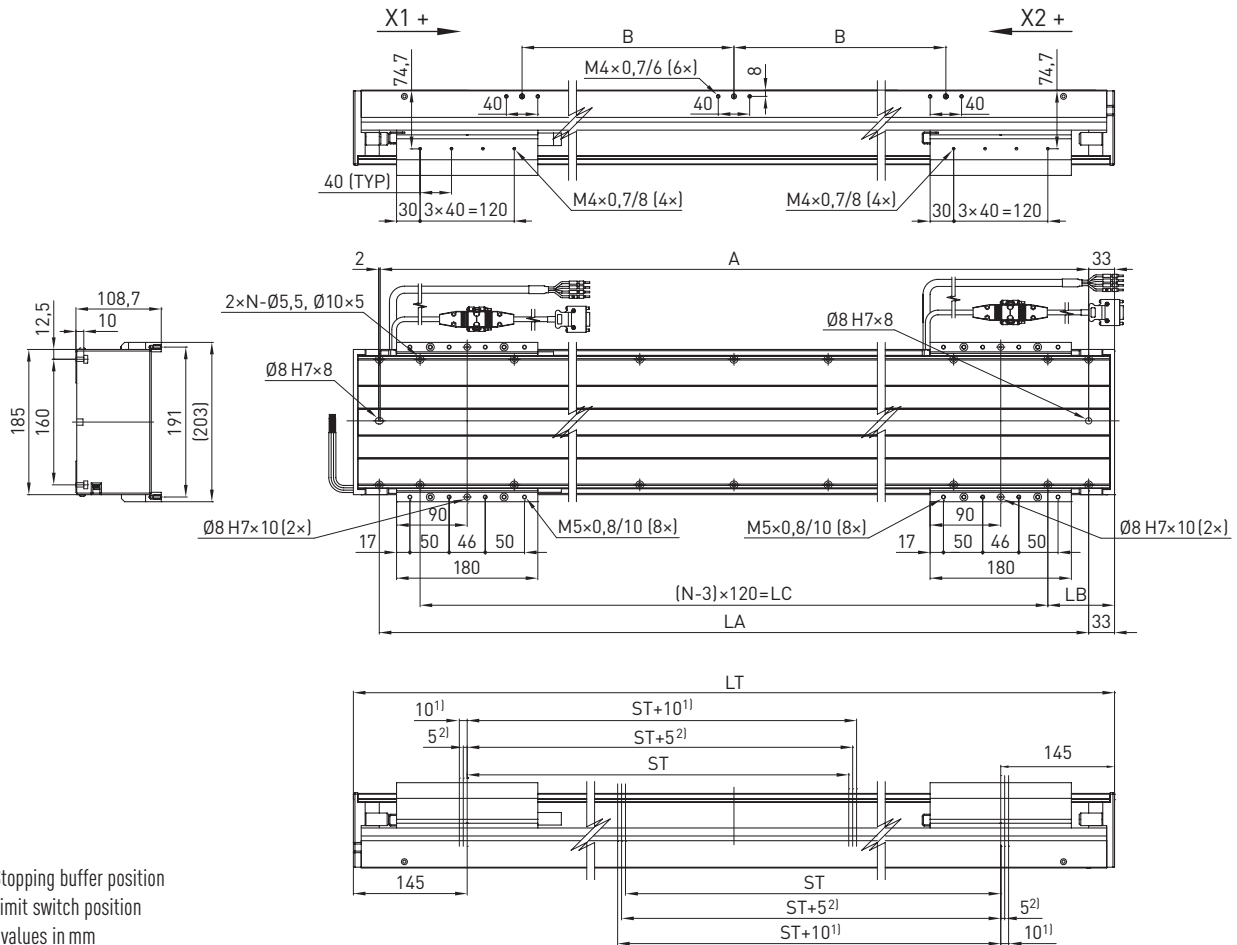

Table 3.37 LMSSA-18S100, -18C100 dimensions, dual forcers, stroke length 1,330 – 2,430 mm

Stroke length ST [mm]	1,330	1,430	1,530	1,630	1,730	1,830	1,930	2,030	2,130	2,230	2,330	2,430
Total length LT [mm]	1,840	1,940	2,040	2,140	2,240	2,340	2,440	2,540	2,640	2,740	2,840	2,940
N [mm]	17	17	19	19	19	21	23	23	23	25	25	25
LA [mm]	1,774	1,874	1,974	2,074	2,174	2,274	2,374	2,474	2,574	2,674	2,774	2,874
LB [mm]	80	130	60	110	160	90	20	70	120	50	100	150
LC [mm]	1,680	1,680	1,920	1,920	1,920	2,160	2,400	2,400	2,400	2,640	2,640	2,640
A [mm]	1,773	1,873	1,973	2,073	2,173	2,273	2,373	2,473	2,573	2,673	2,773	2,873
B [mm]	600	600	600	600	840	840	840	840	840	1,080	1,080	1,080
Stage weight [kg]	18S100	41.6	43.4	45.2	47.0	48.8	50.6	52.4	54.2	55.9	57.7	59.5
	18C100	51.0	53.2	55.4	57.6	59.9	62.1	64.3	66.5	68.8	71.0	73.2

Linear Motor Systems

Linear motor axis LMSSA

LMSSA-18 dimensions, single forcer

LMSSA-18S200, stroke length 200 – 1,500 mm

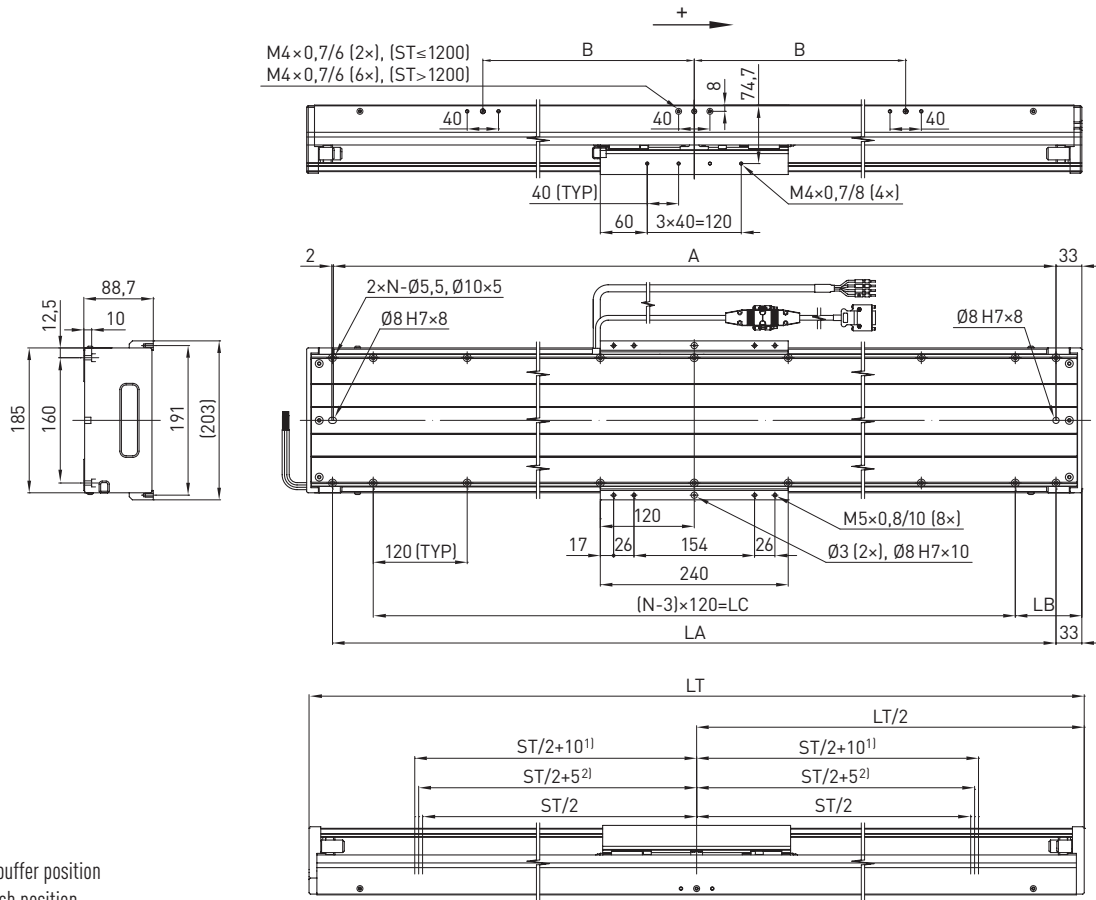

¹⁾ Stopping buffer position

²⁾ Limit switch position

All values in mm

Table 3.38 LMSSA-18S200 dimensions, single forcer, stroke length 200 – 800 mm

Stroke length ST [mm]	200	250	300	350	400	450	500	550	600	650	700	750	800
Total length LT [mm]	550	600	650	700	750	800	850	900	950	1,000	1,050	1,100	1,150
N [mm]	5	7	7	7	7	7	9	9	9	11	11	11	11
LA [mm]	484	534	584	634	684	734	784	834	884	934	984	1,034	1,084
LB [mm]	155	60	85	110	135	160	65	90	115	20	45	70	95
LC [mm]	240	480	480	480	480	480	720	720	720	960	960	960	960
A [mm]	483	533	583	633	683	733	783	783	883	933	983	1,033	1,083
B [mm]	—	—	—	—	—	—	—	—	—	—	—	—	—
Stage weight [kg]	14.2	15.1	16.0	17.0	17.9	18.8	19.7	20.6	21.5	22.4	23.3	24.3	25.2

Table 3.39 LMSSA-18S200 dimensions, single forcer, stroke length 850 – 1,500 mm

Stroke length ST [mm]	850	900	950	1,000	1,050	1,100	1,150	1,200	1,250	1,300	1,400	1,500
Total length LT [mm]	1,200	1,250	1,300	1,350	1,400	1,450	1,500	1,550	1,600	1,650	1,750	1,850
N [mm]	11	11	13	13	13	13	13	15	15	15	15	17
LA [mm]	1,134	1,184	1,234	1,284	1,334	1,384	1,434	1,484	1,534	1,584	1,684	1,784
LB [mm]	120	145	50	75	100	125	150	55	80	105	155	85
LC [mm]	960	960	1,200	1,200	1,200	1,200	1,200	1,440	1,440	1,440	1,440	1,680
A [mm]	1,133	1,183	1,233	1,283	1,333	1,383	1,433	1,483	1,533	1,583	1,683	1,783
B [mm]	—	—	—	—	—	—	—	—	360	360	600	600
Stage weight [kg]	26.1	27.0	27.9	28.8	29.7	30.6	31.6	32.5	33.4	34.3	36.1	37.9

LMSSA-18 dimensions, dual forcers

LMSSA-18S200, stroke length 220 – 1,220 mm

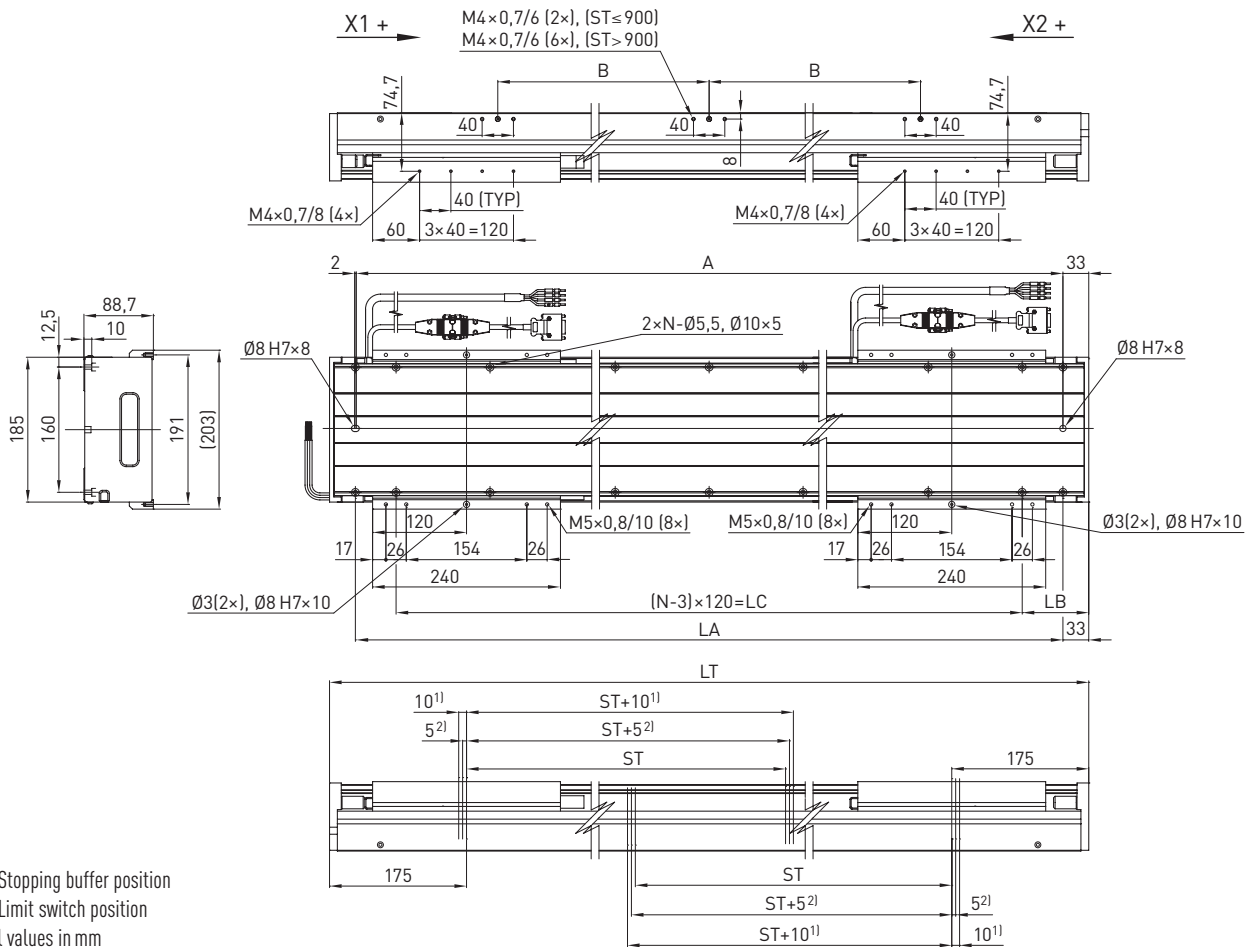

¹⁾ Stopping buffer position
²⁾ Limit switch position
All values in mm

Table 3.40 LMSSA-18S200 dimensions, dual forcers, stroke length 220 – 720 mm

Stroke length ST [mm]	220	270	320	370	420	470	520	570	620	670	720
Total length LT [mm]	850	900	950	1,000	1,050	1,100	1,150	1,200	1,250	1,300	1,350
N [mm]	9	9	9	11	11	11	11	11	11	13	13
LA [mm]	784	834	884	934	984	1,034	1,084	1,134	1,184	1,234	1,284
LB [mm]	65	90	115	20	45	70	95	120	145	50	75
LC [mm]	720	720	720	960	960	960	960	960	960	1,200	1,200
A [mm]	783	833	883	933	983	1,033	1,083	1,133	1,183	1,233	1,283
B [mm]	—	—	—	—	—	—	—	—	—	—	—
Stage weight [kg]	23.8	24.7	25.6	26.5	27.4	28.3	29.2	30.1	31.1	32.0	32.9

Table 3.41 LMSSA-18S200 dimensions, dual forcers, stroke length 770 – 1.220 mm

Stroke length ST [mm]	770	820	870	920	970	1,020	1,070	1,120	1,170	1,220
Total length LT [mm]	1,400	1,450	1,500	1,550	1,600	1,650	1,700	1,750	1,800	1,850
N [mm]	13	13	13	15	15	15	15	15	15	17
LA [mm]	1,334	1,384	1,434	1,484	1,534	1,584	1,634	1,684	1,734	1,784
LB [mm]	100	125	150	55	80	105	130	155	60	85
LC [mm]	1,200	1,200	1,200	1,440	1,440	1,440	1,440	1,440	1,680	1,680
A [mm]	1,333	1,383	1,433	1,483	1,533	1,583	1,633	1,683	1,733	1,783
B [mm]	—	—	—	—	360	360	600	600	600	600
Stage weight [kg]	33.8	34.7	35.6	36.5	37.4	38.3	39.3	40.2	41.1	42.0

Linear Motor Systems

Linear motor axis LMSSA

LMSSA-18 dimensions, single forcer

LMSSA-18S200, stroke length 1,600 – 2,600 mm

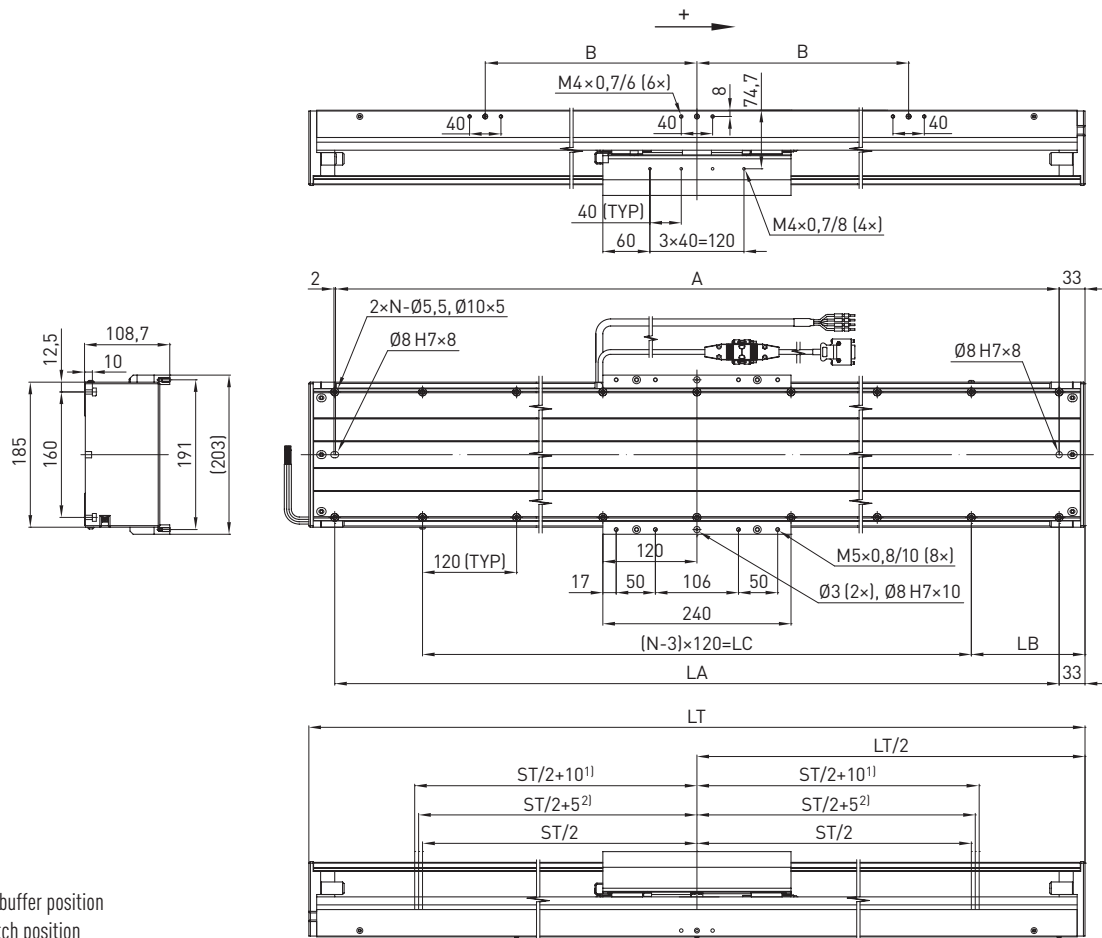

¹⁾ Stopping buffer position

²⁾ Limit switch position

All values in mm

Table 3.42 LMSSA-18S200 dimensions, single forcer, stroke length 1,600 – 2,600 mm

Stroke length ST [mm]	1,600	1,700	1,800	1,900	2,000	2,100	2,200	2,300	2,400	2,500	2,600
Total length LT [mm]	1,950	2,050	2,150	2,250	2,350	2,450	2,550	2,650	2,750	2,850	2,950
N [mm]	17	19	19	21	21	21	23	23	25	25	25
LA [mm]	1,884	1,984	2,084	2,184	2,284	2,384	2,484	2,584	2,684	2,784	2,884
LB [mm]	135	65	115	45	95	145	75	125	55	105	155
LC [mm]	1,680	1,920	1,920	2,160	2,160	2,160	2,400	2,400	2,640	2,640	2,640
A [mm]	1,883	1,983	2,083	2,183	2,283	2,383	2,483	2,583	2,683	2,783	2,883
B [mm]	600	600	600	840	840	840	840	840	1,080	1,080	1,080
Stage weight [kg]	41.8	43.6	45.4	47.2	49.1	50.9	52.7	54.5	56.4	58.2	60.0

LMSSA-18 dimensions, dual forcers

LMSSA-18S200, stroke length 1,270 – 2,320 mm

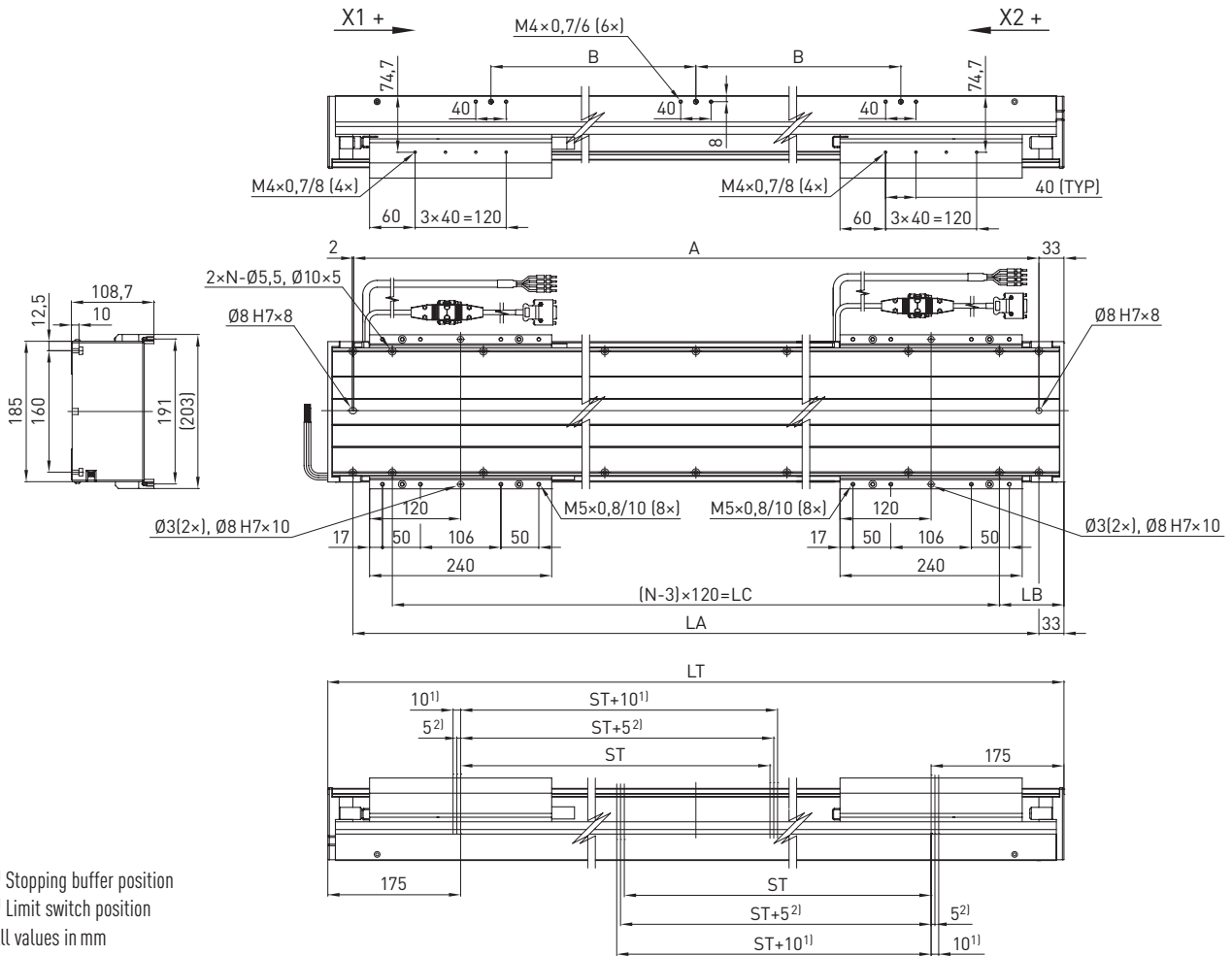

¹) Stopping buffer position
²) Limit switch position
All values in mm

Table 3.43 LMSSA-18S200 dimensions, dual forcers, stroke length 1,270 – 2,320 mm

Stroke length ST [mm]	1,270	1,320	1,420	1,520	1,620	1,720	1,820	1,920	2,020	2,120	2,220	2,320
Total length LT [mm]	1,900	1,950	2,050	2,150	2,250	2,350	2,450	2,550	2,650	2,750	2,850	2,950
N [mm]	17	17	19	19	21	21	21	23	23	25	25	25
LA [mm]	1,834	1,884	1,984	2,084	2,184	2,284	2,384	2,484	2,584	2,684	2,784	2,884
LB [mm]	110	135	65	115	45	95	145	75	125	55	105	155
LC [mm]	1,680	1,680	1,920	1,920	2,160	2,160	2,160	2,400	2,400	2,640	2,640	2,640
A [mm]	1,833	1,883	1,983	2,083	2,183	2,283	2,383	2,483	2,583	2,683	2,783	2,883
B [mm]	600	600	600	600	840	840	840	840	840	1,080	1,080	1,080
Stage weight [kg]	47.0	47.9	49.7	51.5	53.3	55.2	57.0	58.8	60.6	62.5	64.3	66.1

Linear Motor Systems

Linear motor axis LMSSA

LMSSA-18 dimensions, single forcer

LMSSA-18S300, LMSSA-18C200, stroke length 200 – 1,500 mm

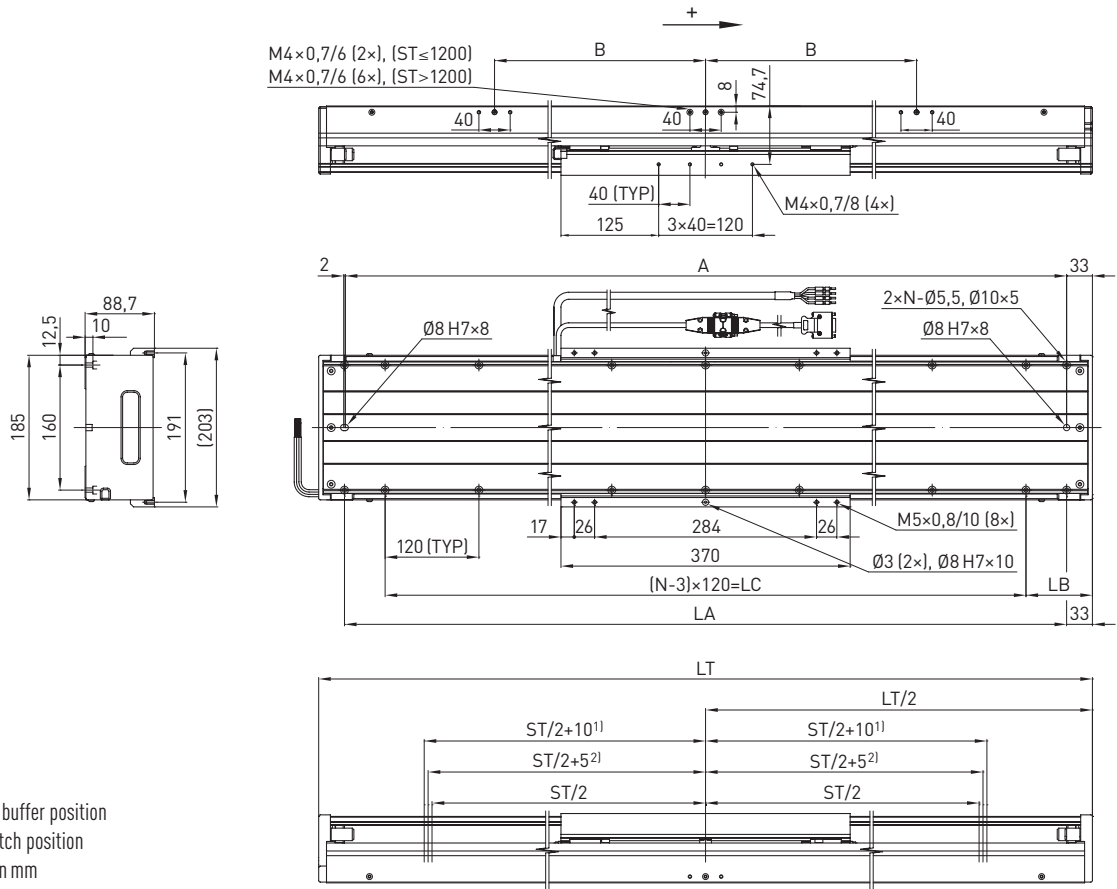

1) Stopping buffer position
 2) Limit switch position
 All values in mm

Table 3.44 LMSSA-18S300, -18C200 dimensions, single forcer, stroke length 200 – 800 mm

Stroke length ST [mm]	200	250	300	350	400	450	500	550	600	650	700	750	800	
Total length LT [mm]	680	730	780	830	880	930	980	1,030	1,080	1,130	1,180	1,230	1,280	
N [mm]	7	7	7	9	9	9	9	9	11	11	11	11	11	
LA [mm]	614	664	714	764	814	864	914	964	1,014	1,064	1,114	1,164	1,214	
LB [mm]	100	125	150	55	80	105	130	155	60	85	110	135	160	
LC [mm]	480	480	480	720	720	720	720	720	960	960	960	960	960	
A [mm]	613	663	713	763	813	863	913	963	1,013	1,063	1,113	1,163	1,213	
B [mm]	—	—	—	—	—	—	—	—	—	—	—	—	—	
Stage weight [kg]	18S300	18.4	19.5	20.7	21.8	23.0	24.2	25.3	26.5	27.6	28.8	30.0	31.1	32.3
	18C200	21.7	22.9	24.1	25.2	26.4	27.5	28.7	29.9	31.0	32.2	33.3	34.5	35.7

Table 3.45 LMSSA-18S300, -18C200 dimensions, single forcer, stroke length 850 – 1,500 mm

Stroke length ST [mm]	850	900	950	1,000	1,050	1,100	1,150	1,200	1,250	1,300	1,400	1,500	
Total length LT [mm]	1,330	1,380	1,430	1,480	1,530	1,580	1,630	1,680	1,730	1,780	1,880	1,980	
N [mm]	13	13	13	15	15	15	15	15	15	17	17	17	
LA [mm]	1,264	1,314	1,364	1,414	1,464	1,514	1,564	1,614	1,664	1,714	1,814	1,914	
LB [mm]	65	90	115	20	45	70	95	120	145	50	100	150	
LC [mm]	1,200	1,200	1,200	1,440	1,440	1,440	1,440	1,440	1,440	1,680	1,680	1,680	
A [mm]	1,263	1,313	1,363	1,413	1,463	1,513	1,563	1,613	1,663	1,713	1,813	1,913	
B [mm]	—	—	—	—	—	—	—	—	600	600	600	600	
Stage weight [kg]	18S300	33.4	34.6	35.8	36.9	38.1	39.2	40.4	41.6	42.7	43.9	46.2	48.5
	18C200	36.8	38.0	39.1	40.3	41.5	42.6	43.8	44.9	46.1	47.3	49.6	51.9

LMSSA-18 dimensions, dual forcers

LMSSA-18S300, LMSSA-18C200, stroke length 240 – 1,090 mm

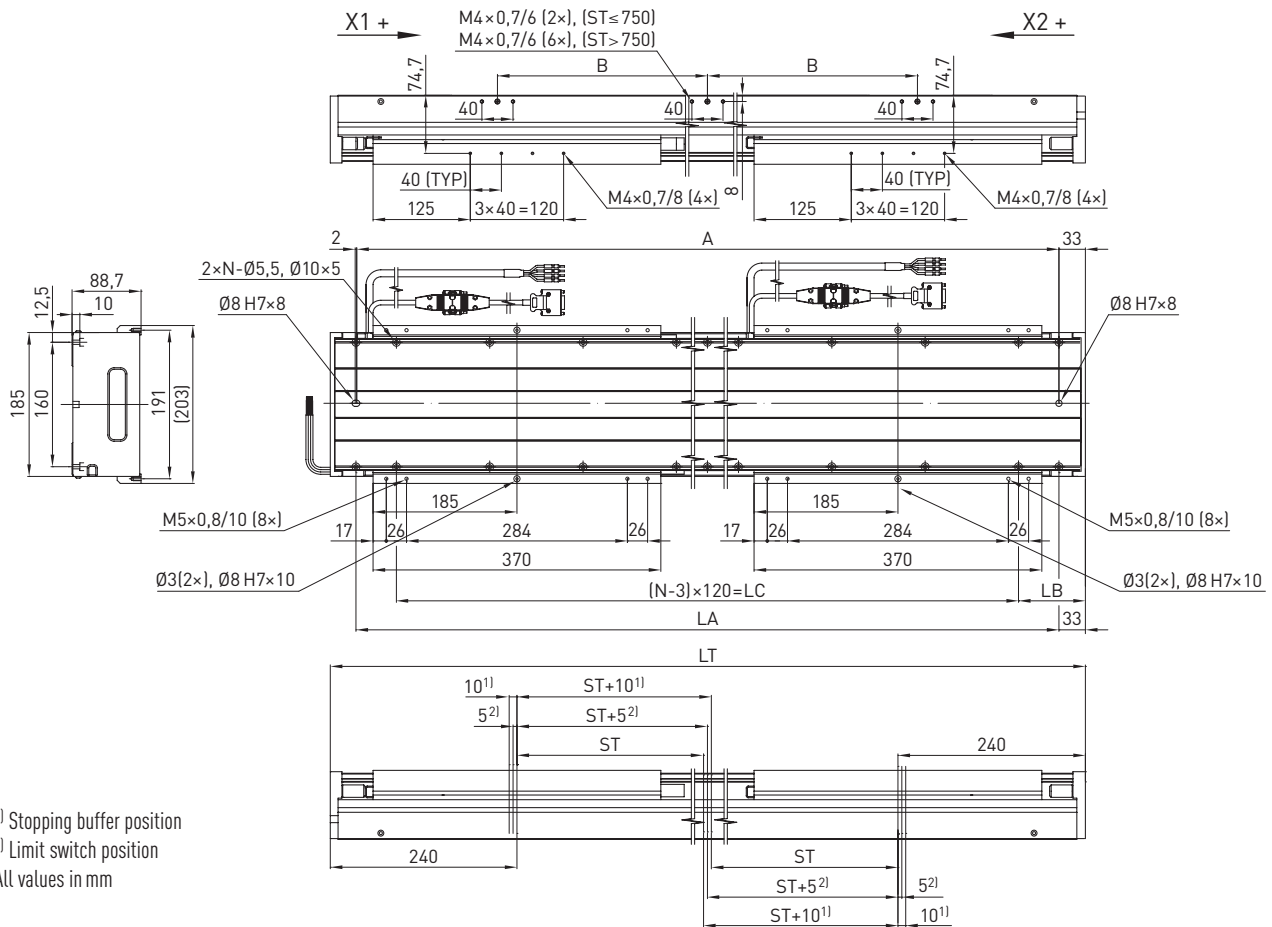

1) Stopping buffer position
2) Limit switch position
All values in mm

Table 3.46 **LMSSA-18S300, -18C200 dimensions, dual forcers, stroke length 240 – 640 mm**

Stroke length ST [mm]	240	290	340	390	440	490	540	590	640	
Total length LT [mm]	1,130	1,180	1,230	1,280	1,330	1,380	1,430	1,480	1,530	
N [mm]	11	11	11	11	13	13	13	15	15	
LA [mm]	1,064	1,114	1,164	1,214	1,264	1,314	1,364	1,414	1,464	
LB [mm]	85	110	135	160	65	90	115	20	45	
LC [mm]	960	960	960	960	1,200	1,200	1,200	1,440	1,440	
A [mm]	1,063	1,113	1,163	1,213	1,263	1,313	1,363	1,413	1,463	
B [mm]	—	—	—	—	—	—	—	—	—	
Stage weight [kg]	18S300	34.5	35.6	36.8	38.0	39.1	40.3	41.4	42.6	43.8
	18C200	36.7	37.9	39.0	40.2	41.4	42.5	43.7	44.8	46.0

Table 3.47 **LMSSA-18S300, -18C200 dimensions, dual forcers, stroke length 690 – 1,090 mm**

Stroke length ST [mm]	690	740	790	840	890	940	990	1,040	1,090	
Total length LT [mm]	1,580	1,630	1,680	1,730	1,780	1,830	1,880	1,930	1,980	
N [mm]	15	15	15	15	17	17	17	17	17	
LA [mm]	1,514	1,564	1,614	1,664	1,714	1,764	1,814	1,864	1,914	
LB [mm]	70	95	120	145	50	75	100	125	150	
LC [mm]	1,440	1,440	1,440	1,440	1,680	1,680	1,680	1,680	1,680	
A [mm]	1,513	1,563	1,613	1,663	1,713	1,763	1,813	1,863	1,913	
B [mm]	—	—	—	600	600	600	600	600	600	
Stage weight [kg]	18S300	44.9	46.1	47.2	48.4	49.6	50.7	51.9	53.0	54.2
	18C200	47.2	48.3	49.5	50.6	51.8	53.0	54.1	55.3	56.4

Linear Motor Systems

Linear motor axis LMSSA

LMSSA-18 dimensions, single forcer

LMSSA-18S300, LMSSA-18C200, stroke length 1,600 – 2,500 mm

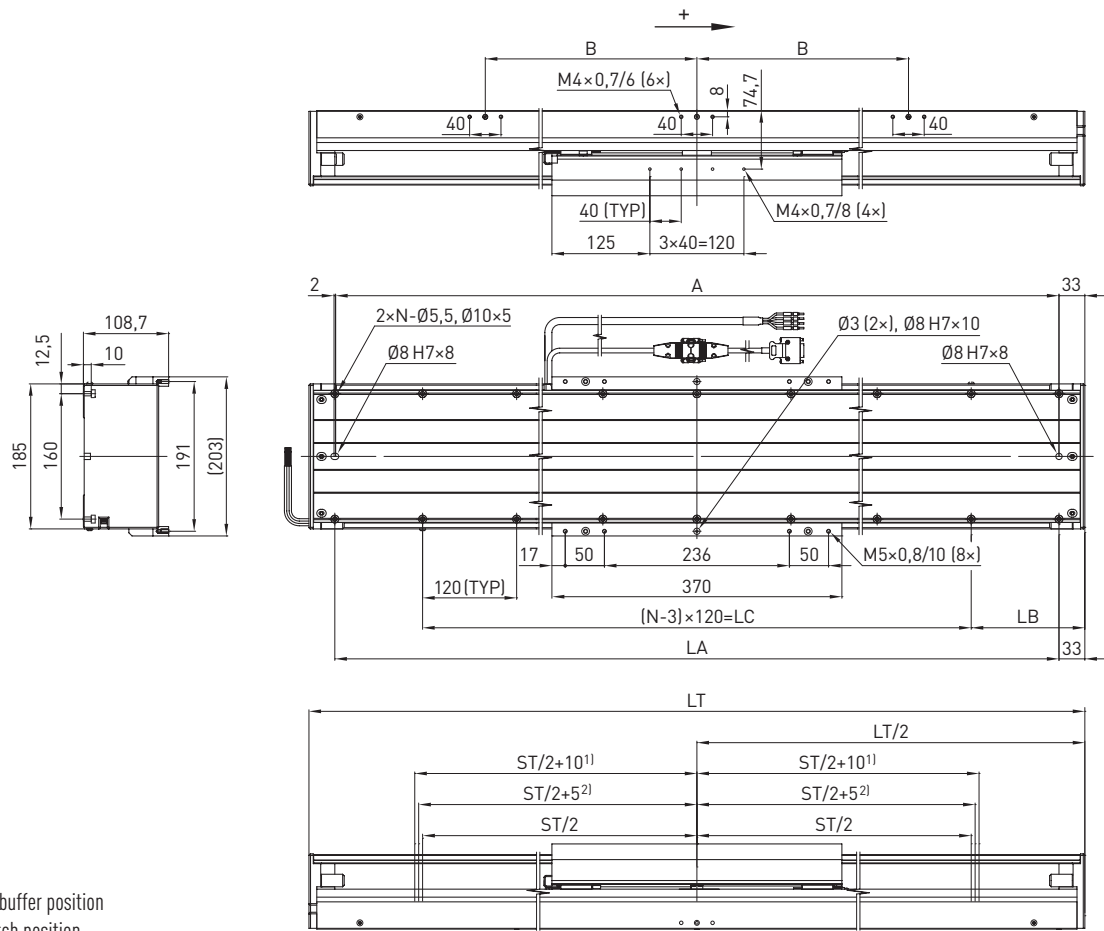

¹⁾ Stopping buffer position

²⁾ Limit switch position

All values in mm

Table 3.48 LMSSA-18S300, -18C200 dimensions, single forcer, stroke length 1,600 – 2,500 mm

Stroke length ST [mm]	1,600	1,700	1,800	1,900	2,000	2,100	2,200	2,300	2,400	2,500	
Total length LT [mm]	2,080	2,180	2,280	2,380	2,480	2,580	2,680	2,780	2,880	2,980	
N [mm]	19	19	21	21	21	23	25	25	25	27	
LA [mm]	2,014	2,114	2,214	2,314	2,414	2,514	2,614	2,714	2,814	2,914	
LB [mm]	80	130	60	110	160	90	20	70	120	50	
LC [mm]	1,920	1,920	2,160	2,160	2,160	2,400	2,640	2,640	2,640	2,880	
A [mm]	2,013	2,113	2,213	2,313	2,413	2,513	2,613	2,713	2,813	2,913	
B [mm]	600	840	840	840	840	840	1,080	1,080	1,080	1,080	
Stage weight [kg]	18S300	53.8	56.2	58.5	60.8	63.1	65.4	67.8	70.1	72.4	74.7
	18C200	57.2	59.5	61.9	64.2	66.5	68.8	71.1	73.5	75.8	78.1

LMSSA-18 dimensions, dual forcers

LMSSA-18S300, LMSSA-18C200, stroke length 1,140 – 2,040 mm

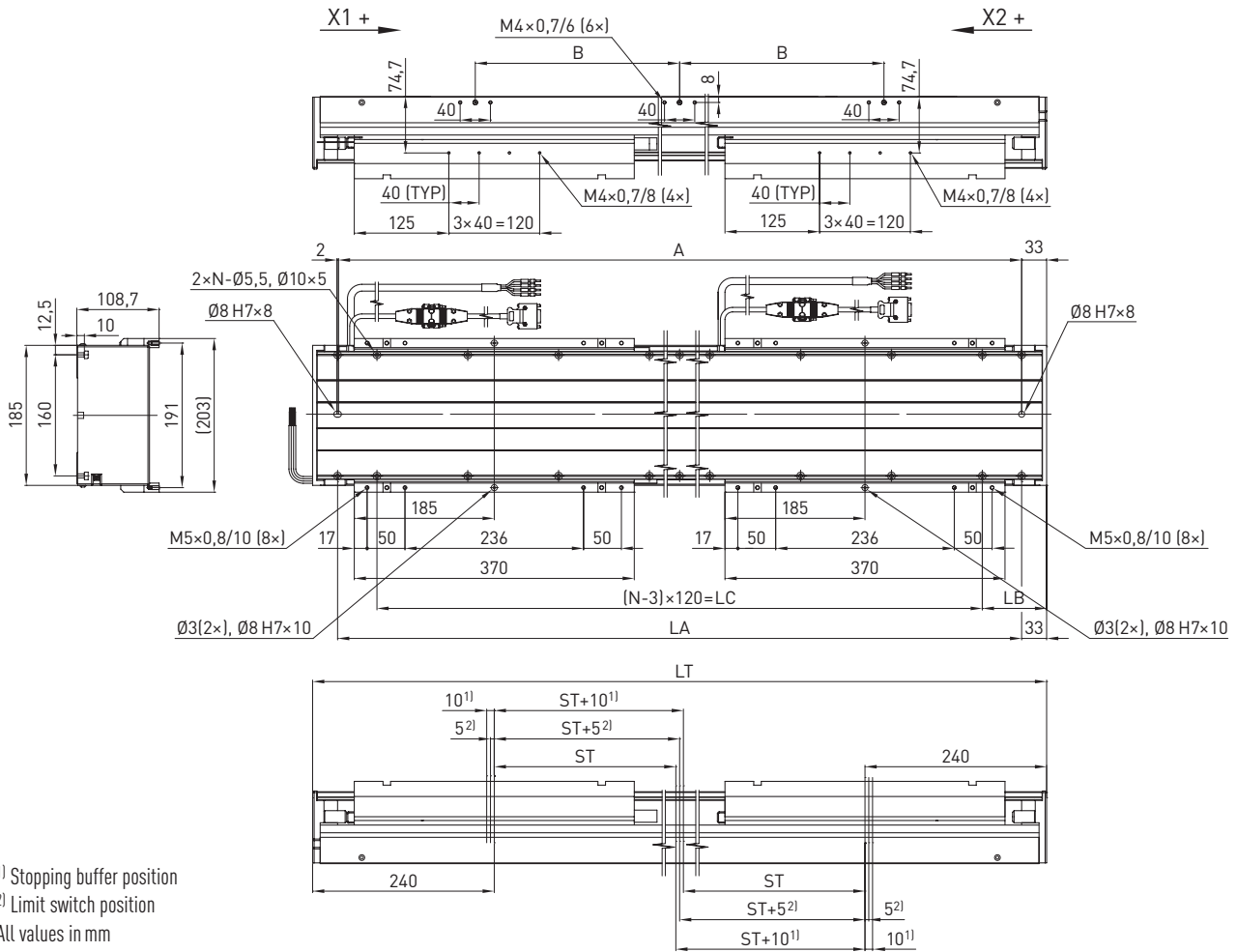

Table 3.49 **LMSSA-18S300, -18C200 dimensions, dual forcers, stroke length 1,140 – 2,040 mm**

Stroke length ST [mm]	1,140	1,190	1,240	1,290	1,340	1,440	1,540	1,640	1,740	1,840	1,940	2,040
Total length LT [mm]	2,030	2,080	2,130	2,180	2,230	2,330	2,430	2,530	2,630	2,730	2,830	2,930
N [mm]	19	19	19	19	19	21	21	23	23	25	25	25
LA [mm]	1,964	2,014	2,064	2,114	2,164	2,264	2,364	2,464	2,564	2,664	2,764	2,864
LB [mm]	55	80	105	130	155	85	135	65	115	45	95	145
LC [mm]	1,920	1,920	1,920	1,920	1,920	2,160	2,160	2,400	2,400	2,640	2,640	2,640
A [mm]	1,963	2,013	2,063	2,113	2,163	2,263	2,363	2,463	2,563	2,663	2,763	2,863
B [mm]	600	600	600	840	840	840	840	840	840	1,080	1,080	1,080
Stage weight [kg]	18S300	61.4	62.5	63.7	64.8	66.0	68.3	70.6	73.0	75.3	77.6	79.9
	18C200	63.6	64.8	65.9	67.1	68.2	70.6	72.9	75.2	77.5	79.8	82.5

Linear Motor Systems

Linear motor axis LMSSA

LMSSA-20 dimensions, single forcer

LMSSA-20S300, LMSSA-20C100, stroke length 200 – 1,500 mm

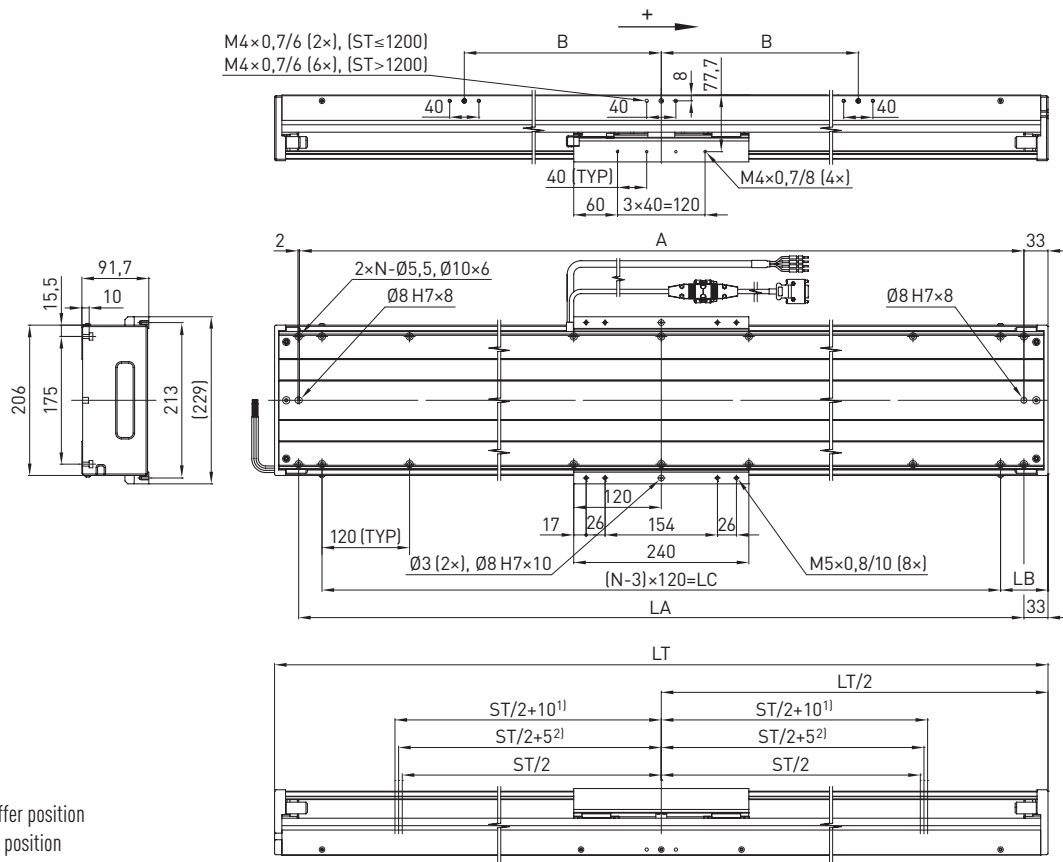

1) Stopping buffer position
 2) Limit switch position
 All values in mm

Table 3.50 LMSSA-20S300, -20C100 dimensions, single forcer, stroke length 200 – 800 mm

Stroke length ST [mm]	200	250	300	350	400	450	500	550	600	650	700	750	800	
Total length LT [mm]	550	600	650	700	750	800	850	900	950	1,000	1,050	1,100	1,150	
N [mm]	5	7	7	7	7	7	9	9	9	11	11	11	11	
LA [mm]	484	534	584	634	684	734	784	834	884	934	984	1,034	1,084	
LB [mm]	155	60	85	110	135	160	65	90	115	20	45	70	95	
LC [mm]	240	480	480	480	480	480	720	720	720	960	960	960	960	
A [mm]	483	533	583	633	683	733	783	833	883	933	983	1,033	1,083	
B [mm]	—	—	—	—	—	—	—	—	—	—	—	—	—	
Stage weight [kg]	20S300	18.0	19.1	20.2	21.3	22.4	23.5	24.6	25.7	26.8	27.9	29.0	30.1	31.2
	20C100	19.4	20.9	22.4	23.9	25.4	26.9	28.4	29.9	31.4	32.9	34.4	36.0	37.5

Table 3.51 LMSSA-20S300, -20C100 dimensions, single forcer, stroke length 850 – 1,500 mm

Stroke length ST [mm]	850	900	950	1,000	1,050	1,100	1,150	1,200	1,250	1,300	1,400	1,500
Total length LT [mm]	1,200	1,250	1,300	1,350	1,400	1,450	1,500	1,550	1,600	1,650	1,750	1,850
N [mm]	11	11	13	13	13	13	13	15	15	15	15	17
LA [mm]	1,134	1,184	1,234	1,284	1,334	1,384	1,434	1,484	1,534	1,584	1,684	1,784
LB [mm]	120	145	50	75	100	125	150	55	80	105	155	85
LC [mm]	960	960	1,200	1,200	1,200	1,200	1,200	1,440	1,440	1,440	1,440	1,680
A [mm]	1,133	1,183	1,233	1,283	1,333	1,383	1,433	1,483	1,533	1,583	1,683	1,783
B [mm]	—	—	—	—	—	—	—	—	360	360	600	600
Stage weight [kg]	20S300	32.3	33.4	34.5	35.6	36.7	37.8	38.9	40.0	41.1	44.4	46.6
	20C100	39.0	40.5	42.0	43.5	45.0	46.5	48.0	49.5	51.0	55.6	58.6

LMSSA-20 dimensions, dual forcers

LMSSA-20S300, LMSSA-20C100, stroke length 220 – 1,220 mm

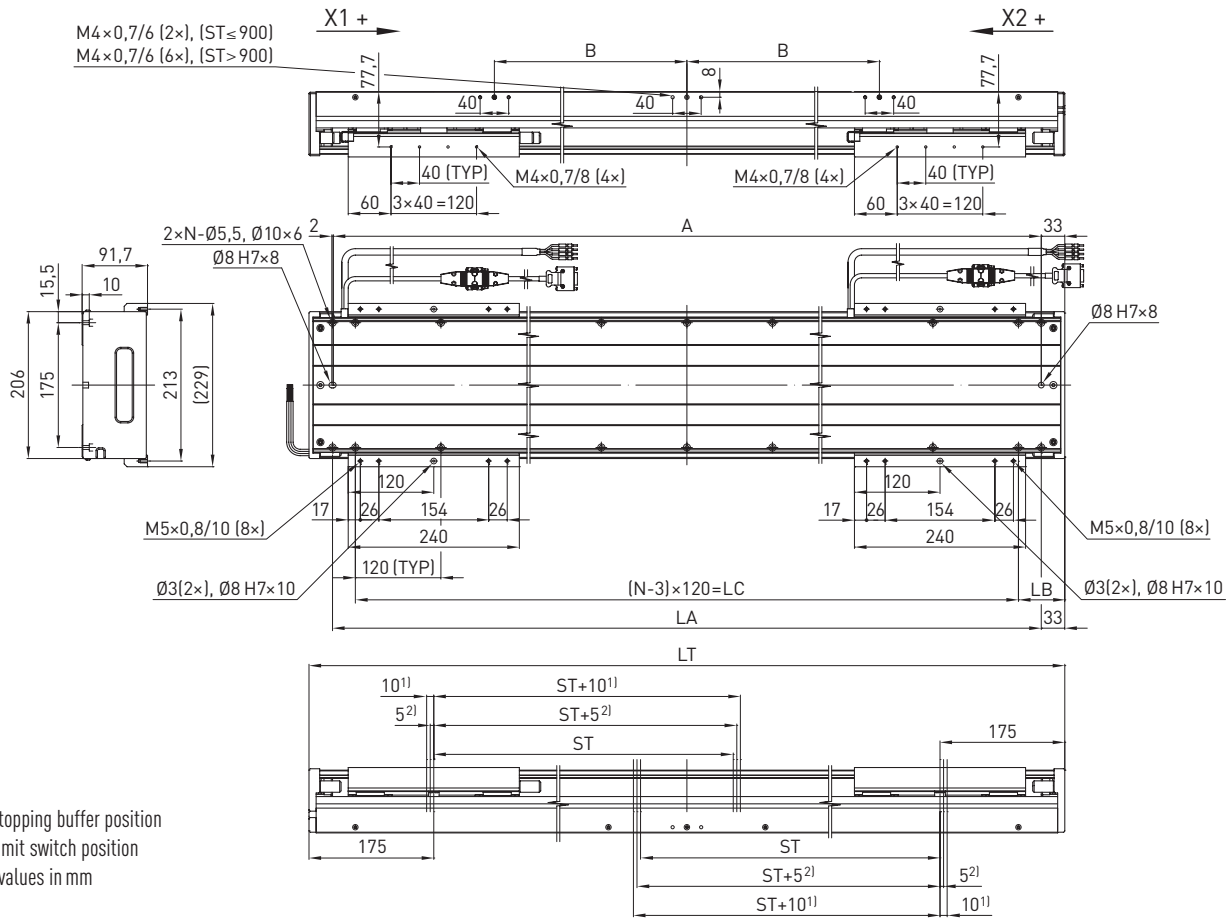

1) Stopping buffer position
2) Limit switch position
All values in mm

Table 3.52 LMSSA-20S300, -20C100 dimensions, dual forcers, stroke length 220 – 720 mm

Stroke length ST [mm]	220	270	320	370	420	470	520	570	620	670	720	
Total length LT [mm]	850	900	950	1,000	1,050	1,100	1,150	1,200	1,250	1,300	1,350	
N [mm]	9	9	9	11	11	11	11	11	11	13	13	
LA [mm]	784	834	884	934	984	1,034	1,084	1,134	1,184	1,234	1,284	
LB [mm]	65	90	115	20	45	70	95	120	145	50	75	
LC [mm]	720	720	720	960	960	960	960	960	960	1,200	1,200	
A [mm]	783	833	883	933	983	1,033	1,083	1,133	1,183	1,233	1,283	
B [mm]	—	—	—	—	—	—	—	—	—	—	—	
Stage weight [kg]	20S300	30.2	31.3	32.4	33.5	34.6	35.7	36.8	37.9	39.0	40.1	41.2
	20C100	32.3	33.8	35.3	36.8	38.3	39.9	41.4	42.9	44.4	45.9	47.4

Table 3.53 LMSSA-20S300, -20C100 dimensions, dual forcers, stroke length 770 – 1,220 mm

Stroke length ST [mm]	770	820	870	920	970	1,020	1,070	1,120	1,170	1,220	
Total length LT [mm]	1,400	1,450	1,500	1,550	1,600	1,650	1,700	1,750	1,800	1,850	
N [mm]	13	13	13	15	15	15	15	15	15	17	
LA [mm]	1,334	1,384	1,434	1,484	1,534	1,584	1,634	1,684	1,734	1,784	
LB [mm]	100	125	150	55	80	105	130	155	60	85	
LC [mm]	1,200	1,200	1,200	1,440	1,440	1,440	1,440	1,440	1,680	1,680	
A [mm]	1,333	1,383	1,433	1,483	1,533	1,583	1,633	1,683	1,733	1,783	
B [mm]	—	—	—	—	360	360	600	600	600	600	
Stage weight [kg]	20S300	42.3	43.4	44.5	45.6	46.7	47.8	48.9	50.0	51.1	52.2
	20C100	48.9	50.4	51.9	53.4	54.9	56.5	58.0	59.5	61.0	62.5

Linear Motor Systems

Linear motor axis LMSSA

LMSSA-20 dimensions, single forcer

LMSSA-20S300, LMSSA-20C100, stroke length 1,600 – 2,600 mm

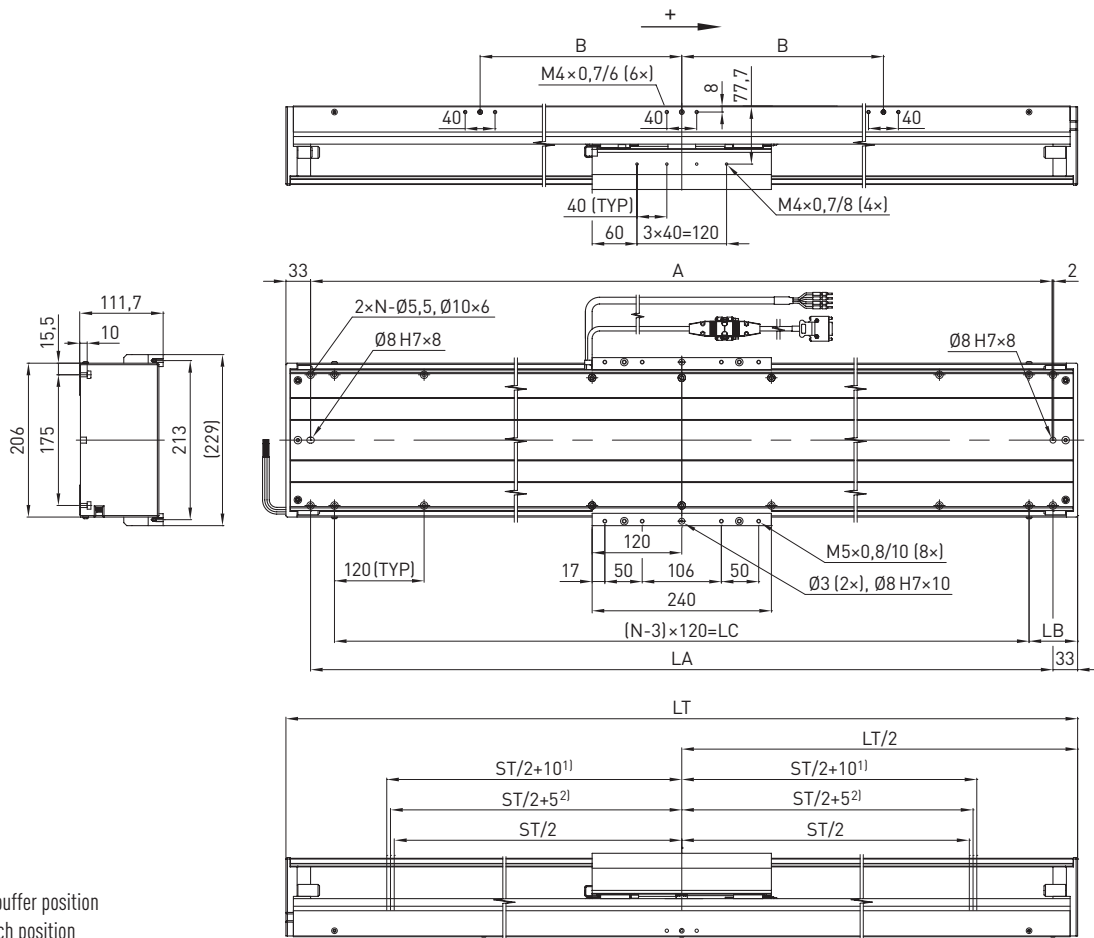

¹⁾ Stopping buffer position

²⁾ Limit switch position

All values in mm

Table 3.54 LMSSA-20S300, -20C100 dimensions, single forcer, stroke length 1,600 – 2,600 mm

Stroke length ST [mm]	1,600	1,700	1,800	1,900	2,000	2,100	2,200	2,300	2,400	2,500	2,600	
Total length LT [mm]	1,950	2,050	2,150	2,250	2,350	2,450	2,550	2,650	2,750	2,850	2,950	
N [mm]	17	19	19	21	21	21	23	23	25	25	25	
LA [mm]	1,884	1,984	2,084	2,184	2,284	2,384	2,484	2,584	2,684	2,784	2,884	
LB [mm]	135	65	115	45	95	145	75	125	55	105	155	
LC [mm]	1,680	1,920	1,920	2,160	2,160	2,160	2,400	2,400	2,640	2,640	2,640	
A [mm]	1,883	1,983	2,083	2,183	2,283	2,383	2,483	2,583	2,683	2,783	2,883	
B [mm]	600	600	600	840	840	840	840	840	1,080	1,080	1,080	
Stage weight [kg]	20S300	50.8	53.0	55.2	57.4	59.6	61.8	64.0	66.2	68.4	70.6	72.8
	20C100	63.6	66.6	69.6	72.7	75.7	78.7	81.7	84.7	87.8	90.8	93.8

LMSSA-20 dimensions, dual forcers

LMSSA-20S300, LMSSA-20C100, stroke length 1,270 – 2,320 mm

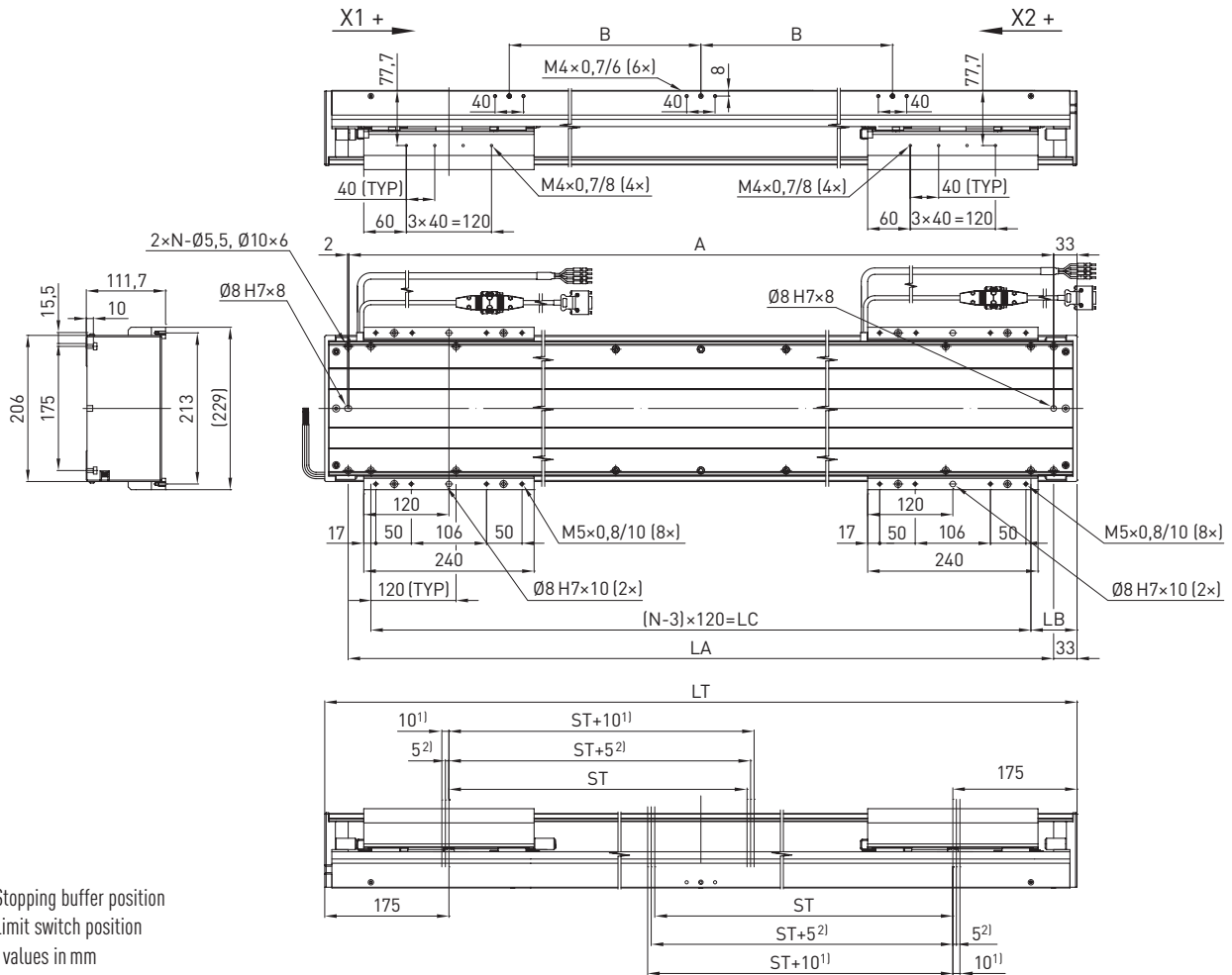

Table 3.55 LMSSA-20S300, -20C100 dimensions, dual forcers, stroke length 1,270 – 2,320 mm

Stroke length ST [mm]	1,270	1,320	1,420	1,520	1,620	1,720	1,820	1,920	2,020	2,120	2,220	2,320
Total length LT [mm]	1,900	1,950	2,050	2,150	2,250	2,350	2,450	2,550	2,650	2,750	2,850	2,950
N [mm]	17	17	19	19	21	21	21	23	23	25	25	25
LA [mm]	1,834	1,884	1,984	2,084	2,184	2,284	2,384	2,484	2,584	2,684	2,784	2,884
LB [mm]	110	135	65	115	45	95	145	75	125	55	105	155
LC [mm]	1,680	1,680	1,920	1,920	2,160	2,160	2,160	2,400	2,400	2,640	2,640	2,640
A [mm]	1,833	1,883	1,983	2,083	2,183	2,283	2,383	2,483	2,583	2,683	2,783	2,883
B [mm]	600	600	600	600	840	840	840	840	840	1,080	1,080	1,080
Stage weight [kg]	20S300	55.3	56.4	58.6	60.8	66.0	67.2	69.4	71.6	73.8	76.0	80.4
	20C100	68.0	69.5	72.5	75.5	78.6	81.6	84.6	87.6	90.6	93.7	99.7

Linear Motor Systems

Linear motor axis LMSSA

LMSSA-20 dimensions, single forcer

LMSSA-20S500, LMSSA-20C200, stroke length 200 – 1,500 mm

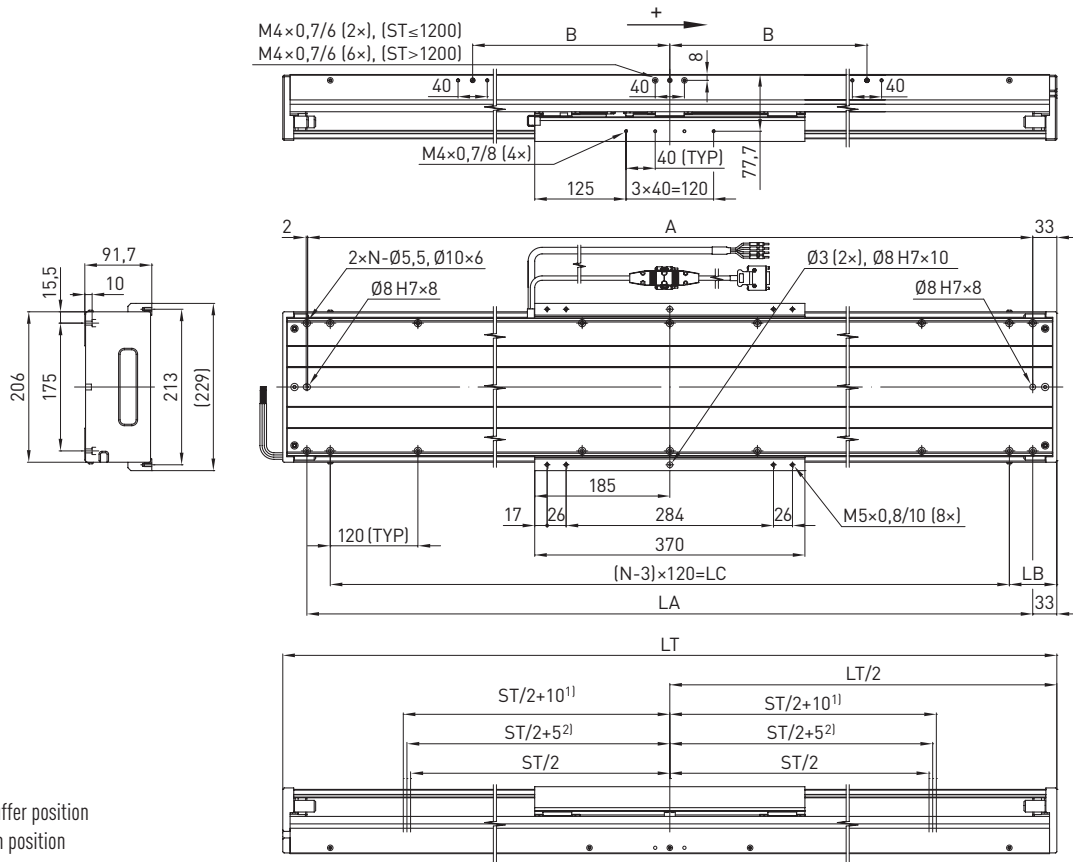

1) Stopping buffer position
 2) Limit switch position
 All values in mm

Table 3.56 LMSSA-20S500, -20C200 dimensions, single forcer, stroke length 200 – 800 mm

Stroke length ST [mm]	200	250	300	350	400	450	500	550	600	650	700	750	800	
Total length LT [mm]	680	730	780	830	880	930	980	1,030	1,080	1,130	1,180	1,230	1,280	
N [mm]	7	7	7	9	9	9	9	9	11	11	11	11	11	
LA [mm]	614	664	714	764	814	864	914	964	1,014	1,064	1,114	1,164	1,214	
LB [mm]	100	125	150	55	80	105	130	155	60	85	110	135	160	
LC [mm]	480	480	480	720	720	720	720	720	960	960	960	960	960	
A [mm]	613	663	713	763	813	863	913	963	1,013	1,063	1,113	1,163	1,213	
B [mm]	—	—	—	—	—	—	—	—	—	—	—	—	—	
Stage weight [kg]	20S500	23.1	24.2	25.4	26.5	27.7	28.8	30.0	31.1	32.3	33.4	34.6	35.7	36.9
	20C200	23.8	25.4	26.9	28.5	30.0	31.6	33.2	34.7	36.3	37.9	39.4	41.0	42.5

Table 3.57 LMSSA-20S500, -20C200 dimensions, single forcer, stroke length 850 – 1,500 mm

Stroke length ST [mm]	850	900	950	1,000	1,050	1,100	1,150	1,200	1,250	1,300	1,400	1,500	
Total length LT [mm]	1,330	1,380	1,430	1,480	1,530	1,580	1,630	1,680	1,730	1,780	1,880	1,980	
N [mm]	13	13	13	15	15	15	15	15	15	17	17	17	
LA [mm]	1,264	1,314	1,364	1,414	1,464	1,514	1,564	1,614	1,664	1,714	1,814	1,914	
LB [mm]	65	90	115	20	45	70	95	120	145	50	100	150	
LC [mm]	1,200	1,200	1,200	1,440	1,440	1,440	1,440	1,440	1,440	1,680	1,680	1,680	
A [mm]	1,263	1,313	1,363	1,413	1,463	1,513	1,563	1,613	1,663	1,713	1,813	1,913	
B [mm]	—	—	—	—	—	—	—	—	600	600	600	600	
Stage weight [kg]	20S500	38.0	39.2	40.3	41.5	42.6	43.8	44.9	46.1	47.2	48.4	50.7	53.0
	20C200	44.1	45.7	47.2	48.8	50.4	51.9	53.5	55.1	56.6	58.2	61.3	64.4

LMSSA-20 dimensions, dual forcers

LMSSA-20S500, LMSSA-20C200, stroke length 240 – 1,090 mm

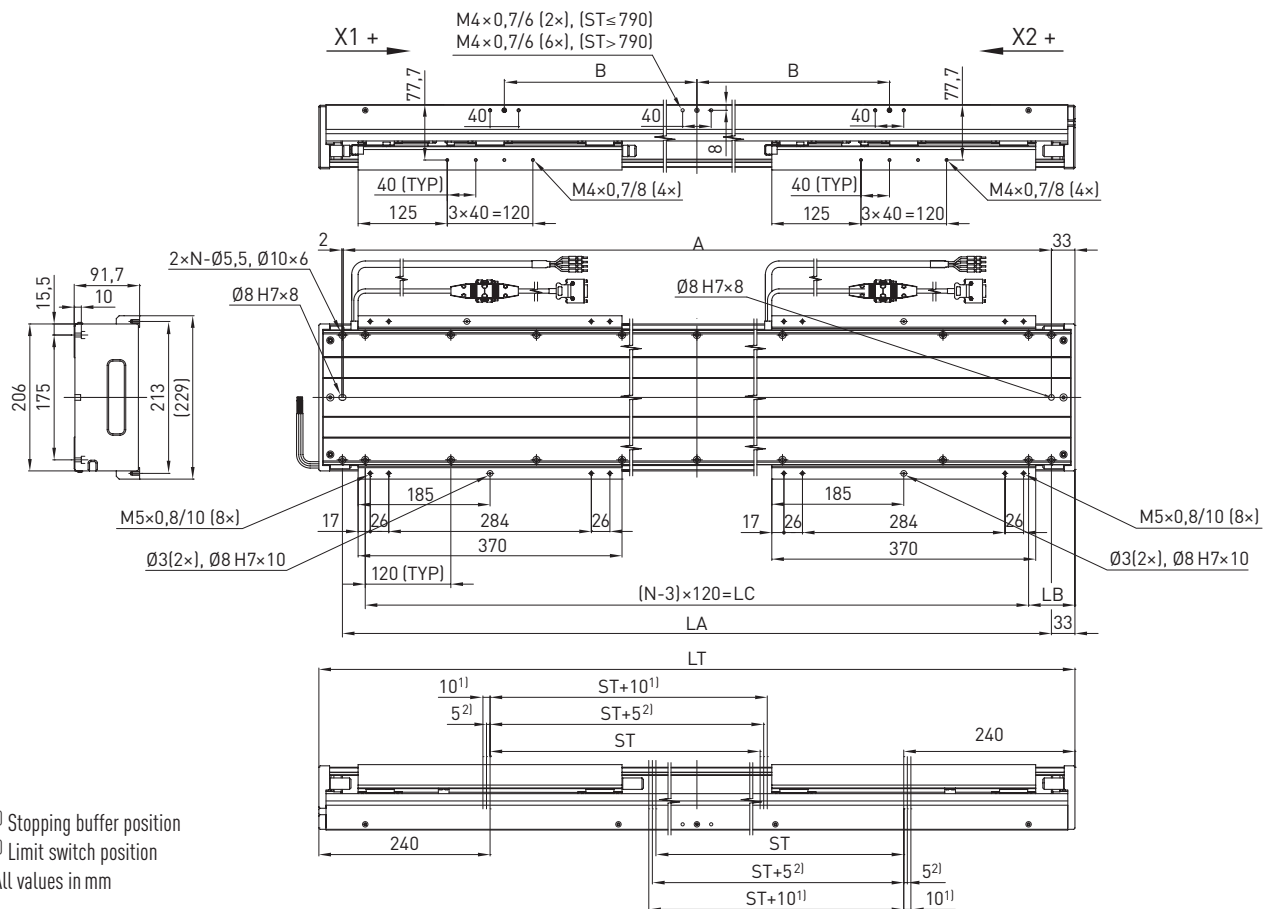

1) Stopping buffer position
2) Limit switch position
All values in mm

Table 3.58 LMSSA-20S500, -20C200 dimensions, dual forcers, stroke length 240 – 640 mm

Stroke length ST [mm]	240	290	340	390	440	490	540	590	640	
Total length LT [mm]	1,130	1,180	1,230	1,280	1,330	1,380	1,430	1,480	1,530	
N [mm]	11	11	11	11	13	13	13	15	15	
LA [mm]	1,064	1,114	1,164	1,214	1,264	1,314	1,364	1,414	1,464	
LB [mm]	85	110	135	160	65	90	115	20	45	
LC [mm]	960	960	960	960	1,200	1,200	1,200	1,440	1,440	
A [mm]	1,063	1,113	1,163	1,213	1,263	1,313	1,363	1,413	1,463	
B [mm]	—	—	—	—	—	—	—	—	—	
Stage weight [kg]	20S500	41.6	42.7	43.8	45.0	46.2	47.3	48.5	49.6	50.8
	20C200	43.4	45.0	46.5	48.1	49.7	51.2	52.8	54.4	55.9

Table 3.59 LMSSA-20S500, -20C200 dimensions, dual forcers, stroke length 690 – 1,090 mm

Stroke length [mm]	690	740	790	840	890	940	990	1,040	1,090	
Total length LT [mm]	1,580	1,630	1,680	1,730	1,780	1,830	1,880	1,930	1,980	
N [mm]	15	15	15	15	17	17	17	17	17	
LA [mm]	1,514	1,564	1,614	1,664	1,714	1,764	1,814	1,864	1,914	
LB [mm]	70	95	120	145	50	75	100	125	150	
LC [mm]	1,440	1,440	1,440	1,440	1,680	1,680	1,680	1,680	1,680	
A [mm]	1,513	1,563	1,613	1,663	1,713	1,763	1,813	1,863	1,913	
B [mm]	—	—	—	600	600	600	600	600	600	
Stage weight [kg]	20S500	51.9	53.1	54.2	55.4	56.5	57.7	58.8	60.0	61.1
	20C200	57.5	59.0	60.6	62.2	63.7	65.3	66.9	68.4	70.0

Linear Motor Systems

Linear motor axis LMSSA

LMSSA-20 dimensions, single forcer

LMSSA-20S500, LMSSA-20C200, stroke length 1,600 – 2,500 mm

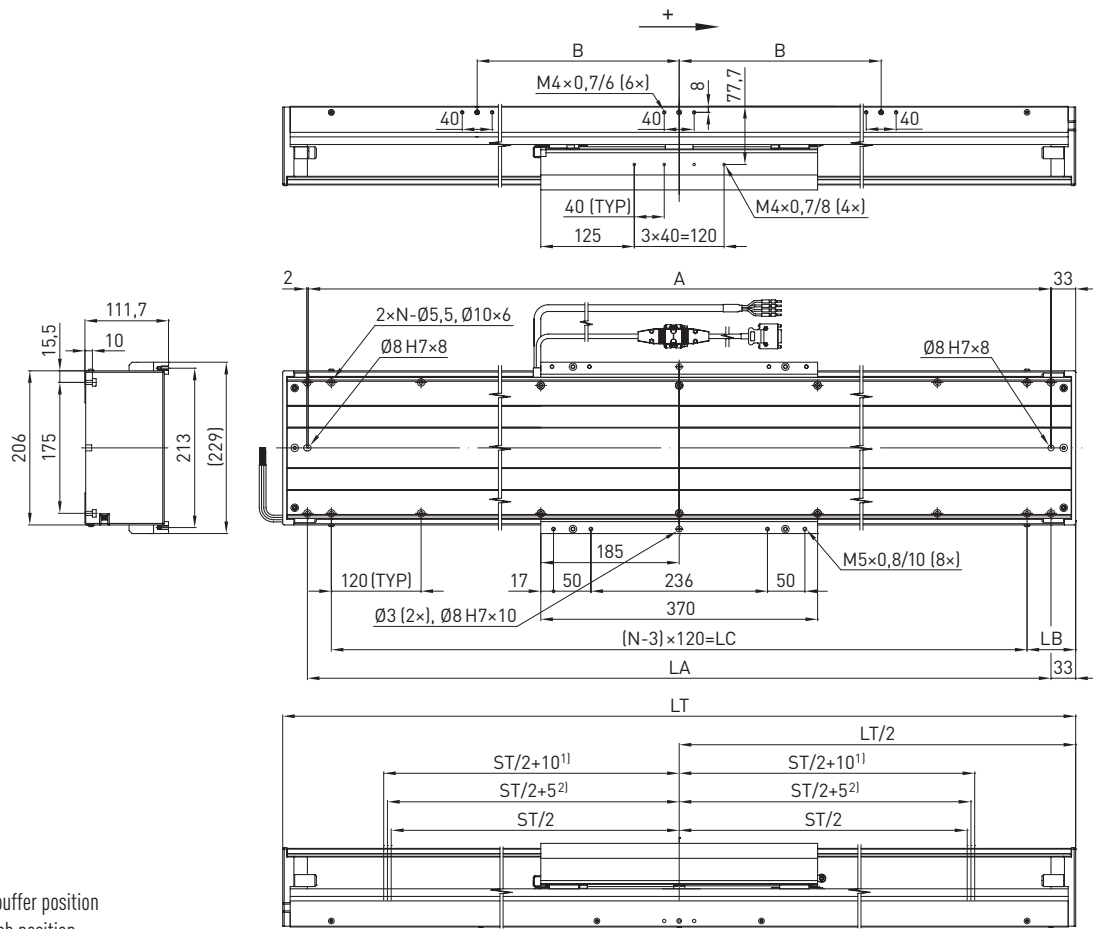

¹⁾ Stopping buffer position

²⁾ Limit switch position

All values in mm

Table 3.60 LMSSA-20S500, -20C200 dimensions, single forcer, stroke length 1,600 – 2,500 mm

Stroke length ST [mm]	1,600	1,700	1,800	1,900	2,000	2,100	2,200	2,300	2,400	2,500	
Total length LT [mm]	2,080	2,180	2,280	2,380	2,480	2,580	2,680	2,780	2,880	2,980	
N [mm]	19	19	21	21	21	23	25	25	25	27	
LA [mm]	2,014	2,114	2,214	2,314	2,414	2,514	2,614	2,714	2,814	2,914	
LB [mm]	80	130	60	110	160	90	20	70	120	50	
LC [mm]	1,920	1,920	2,160	2,160	2,160	2,400	2,640	2,640	2,640	2,880	
A [mm]	2,013	2,113	2,213	2,313	2,413	2,513	2,613	2,713	2,813	2,913	
B [mm]	600	840	840	840	840	840	1,080	1,080	1,080	1,080	
Stage weight [kg]	20S500	58.3	60.6	62.9	65.2	67.5	69.8	72.1	74.4	76.7	79.0
	20C200	70.6	73.7	76.8	79.9	83.1	86.2	89.3	92.4	95.6	98.7

LMSSA-20 dimensions, dual forcers

LMSSA-20S500, LMSSA-20C200, stroke length 1,140 – 2,040 mm

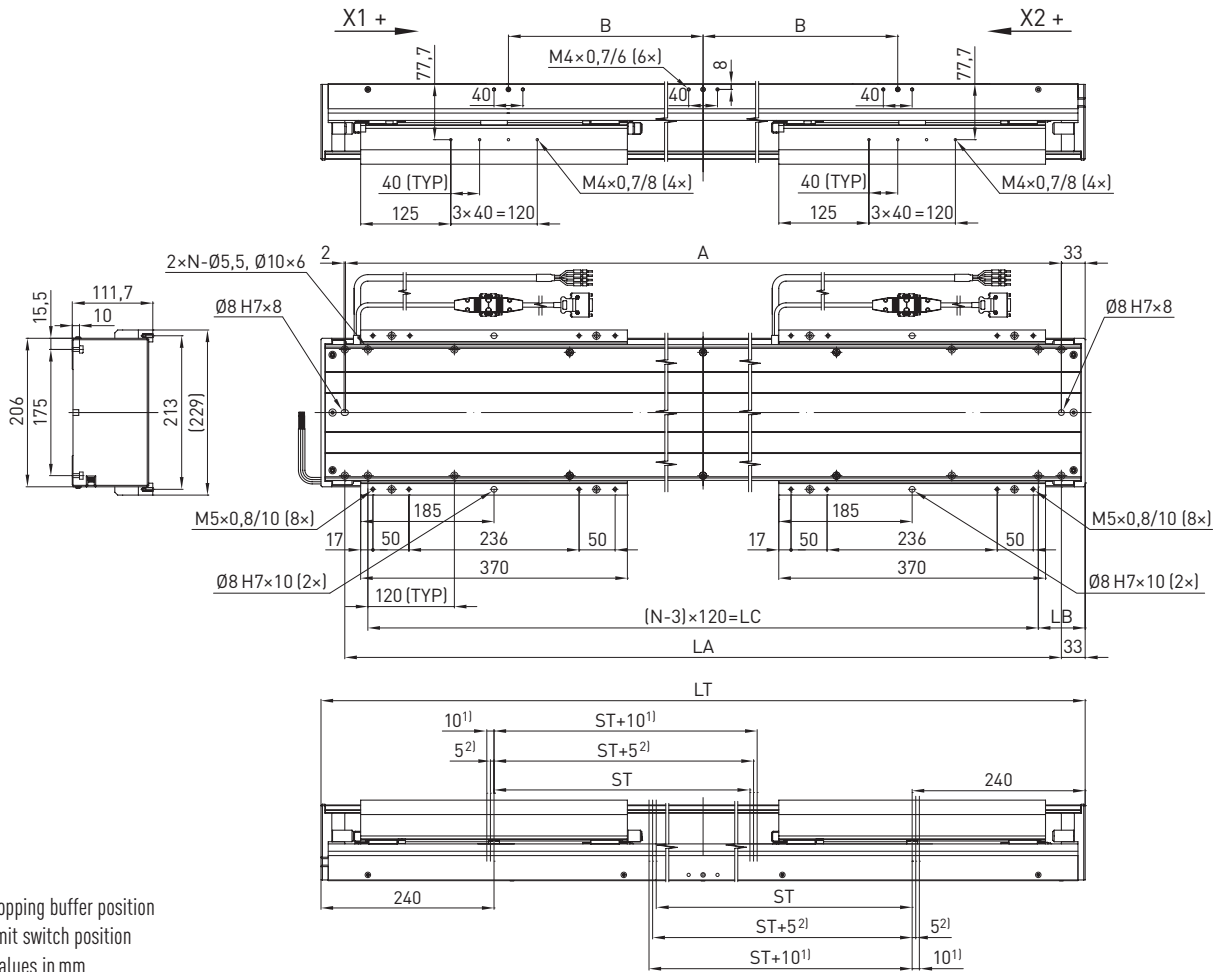

1) Stopping buffer position
2) Limit switch position
All values in mm

Table 3.61 LMSSA-20S500, -20C200 dimensions, dual forcers, stroke length 1,140 – 2,040 mm

Stroke length ST [mm]	1,140	1,190	1,240	1,290	1,340	1,440	1,540	1,640	1,740	1,840	1,940	2,040	
Total length LT [mm]	2,030	2,080	2,130	2,180	2,230	2,330	2,430	2,530	2,630	2,730	2,830	2,930	
N [mm]	19	19	19	19	19	21	21	23	23	25	25	25	
LA [mm]	1,964	2,014	2,064	2,114	2,164	2,264	2,364	2,464	2,564	2,664	2,764	2,864	
LB [mm]	55	80	105	130	155	85	135	65	115	45	95	145	
LC [mm]	1,920	1,920	1,920	1,920	1,920	2,160	2,160	2,400	2,400	2,640	2,640	2,640	
A [mm]	1,963	2,013	2,063	2,113	2,163	2,263	2,363	2,463	2,563	2,663	2,763	2,863	
B [mm]	600	600	600	840	840	840	840	840	840	1,080	1,080	1,080	
Stage weight [kg]	20S500	68.3	69.4	70.6	71.7	72.8	75.1	77.4	79.7	82.0	84.3	86.6	88.9
	20C200	77.5	79.1	80.7	82.2	83.8	86.9	90.1	93.2	96.3	99.4	102.6	105.7

Linear Motor Systems

Linear motor axis LMSSA

LMSSA-20 dimensions, single forcer

LMSSA-20S700, stroke length 200 – 1,500 mm

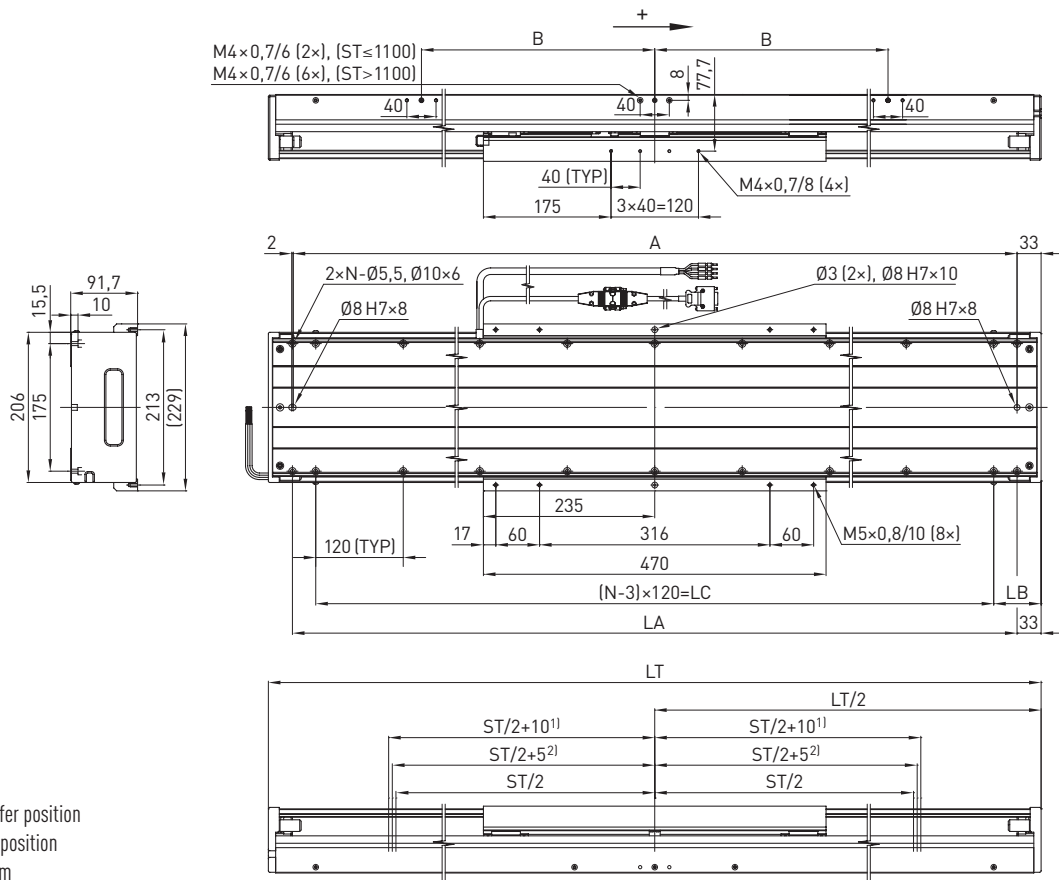

¹⁾ Stopping buffer position

²⁾ Limit switch position

All values in mm

Table 3.62 LMSSA-20S700 dimensions, single forcer, stroke length 200 – 800 mm

Stroke length ST [mm]	200	250	300	350	400	450	500	550	600	650	700	750	800
Total length LT [mm]	780	830	880	930	980	1,030	1,080	1,130	1,180	1,230	1,280	1,330	1,380
N [mm]	7	9	9	9	9	9	11	11	11	11	11	13	13
LA [mm]	714	764	814	864	914	964	1,014	1,064	1,114	1,164	1,214	1,264	1,314
LB [mm]	150	55	80	105	130	155	60	85	110	135	160	65	90
LC [mm]	480	720	720	720	720	720	960	960	960	960	960	1,200	1,200
A [mm]	713	763	813	863	913	963	1,013	1,063	1,113	1,163	1,213	1,263	1,313
B [mm]	—	—	—	—	—	—	—	—	—	—	—	—	—
Stage weight [kg]	27.4	28.5	29.7	30.8	32.0	33.1	34.3	35.4	36.6	37.7	38.9	40.0	41.2

Table 3.63 LMSSA-20S700 dimensions, single forcer, stroke length 850 – 1,500 mm

Stroke length ST [mm]	850	900	950	1,000	1,050	1,100	1,150	1,200	1,250	1,300	1,400	1,500
Total length LT [mm]	1,430	1,480	1,530	1,580	1,630	1,680	1,730	1,780	1,830	1,880	1,980	2,080
N [mm]	13	15	15	15	15	15	15	17	17	17	17	19
LA [mm]	1,364	1,414	1,464	1,514	1,564	1,614	1,664	1,714	1,764	1,814	1,914	2,014
LB [mm]	115	20	45	70	95	120	145	50	75	100	150	80
LC [mm]	1,200	1,440	1,440	1,440	1,440	1,440	1,440	1,680	1,680	1,680	1,680	1,920
A [mm]	1,363	1,413	1,463	1,513	1,563	1,613	1,663	1,713	1,763	1,813	1,913	2,013
B [mm]	—	—	—	—	—	—	600	600	600	600	600	600
Stage weight [kg]	42.3	43.5	44.6	45.8	46.9	48.1	49.2	50.4	51.5	52.7	55.0	60.3

LMSSA-20 dimensions, dual forcers

LMSSA-20S700, stroke length 240 – 890 mm

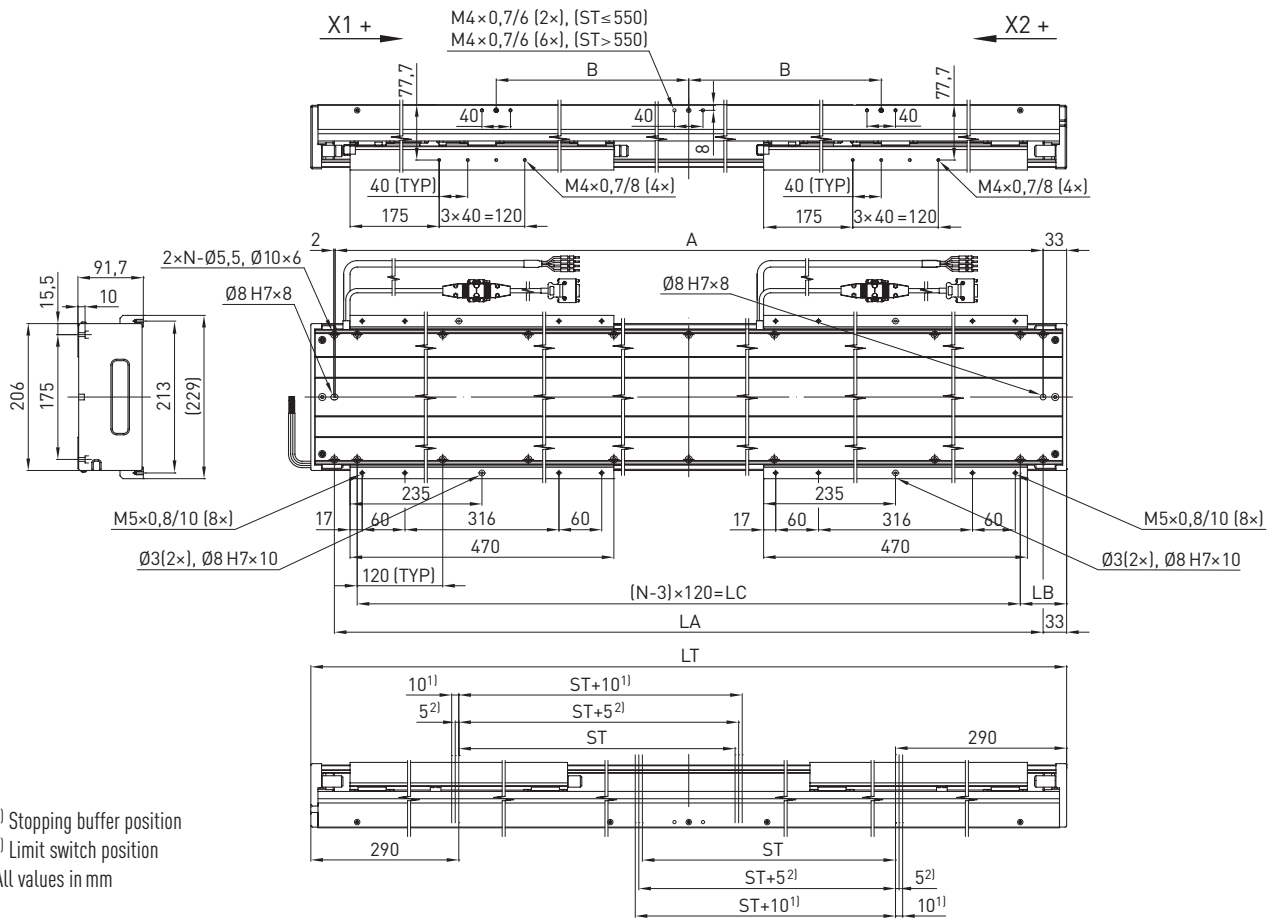

1) Stopping buffer position
2) Limit switch position
All values in mm

Table 3.64 LMSSA-20S700 dimensions, Dual Forcer, stroke length 240 – 890 mm

Stroke length ST [mm]	240	290	340	390	440	490	540	590	640	690	740	790	840	890
Total length LT [mm]	1,330	1,380	1,430	1,480	1,530	1,580	1,630	1,680	1,730	1,780	1,830	1,880	1,930	1,980
N [mm]	13	13	13	15	15	15	15	15	15	17	17	17	17	17
LA [mm]	1,264	1,314	1,364	1,414	1,464	1,514	1,564	1,614	1,664	1,714	1,764	1,814	1,864	1,914
LB [mm]	65	90	115	20	45	70	95	120	145	50	75	100	125	150
LC [mm]	1,200	1,200	1,200	1,440	1,440	1,440	1,440	1,440	1,440	1,680	1,680	1,680	1,680	1,680
A [mm]	1,263	1,313	1,363	1,413	1,463	1,513	1,563	1,613	1,663	1,713	1,763	1,813	1,863	1,913
B [mm]	—	—	—	—	—	—	—	—	600	600	600	600	600	600
Stage weight [kg]	50.5	51.7	52.8	54.0	55.1	56.3	57.4	58.6	59.7	60.9	62.0	63.2	64.3	65.5

Linear Motor Systems

Linear motor axis LMSSA

LMSSA-20 dimensions, single forcer

LMSSA-20S700, stroke length 1,600 – 2,400 mm

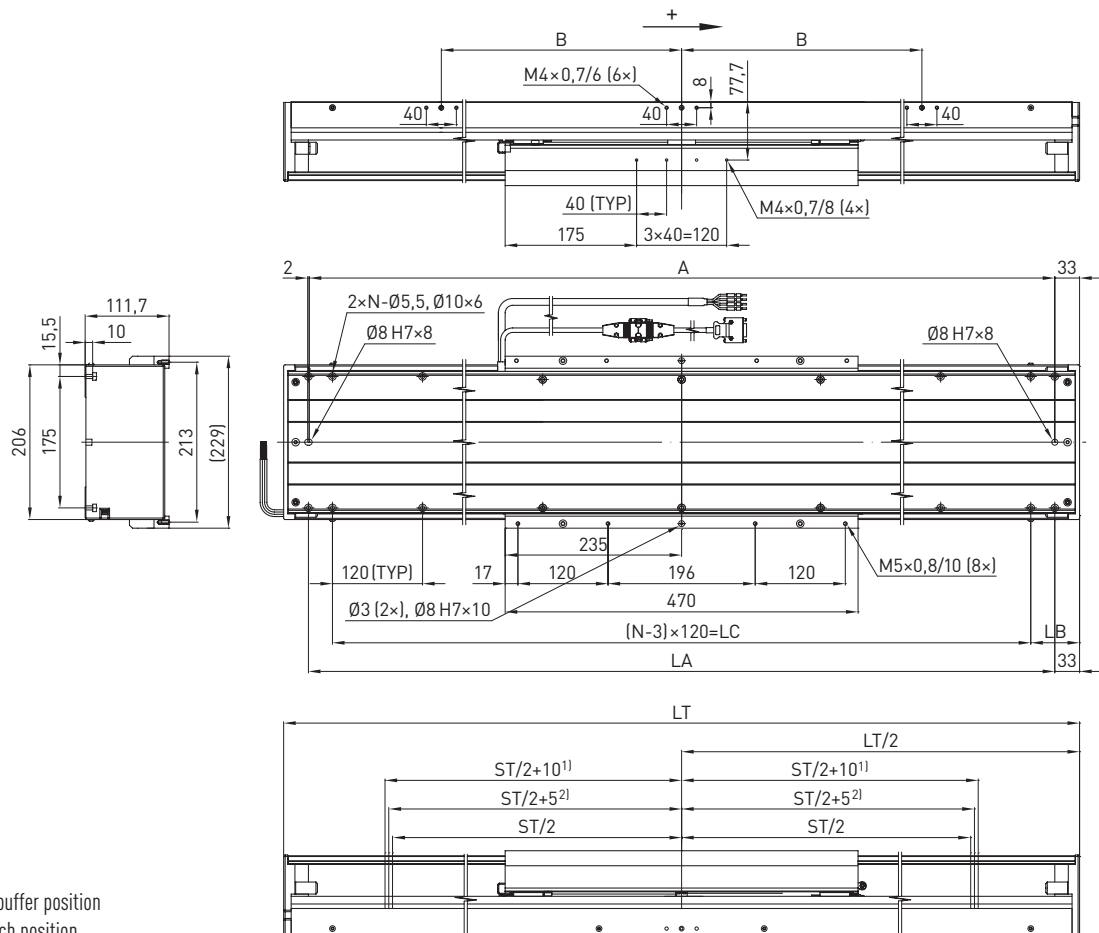

¹⁾ Stopping buffer position

²⁾ Limit switch position

All values in mm

Table 3.65 LMSSA-20S700 dimensions, single forcer, stroke length 1,600 – 2,400 mm

Stroke length ST [mm]	1,600	1,700	1,800	1,900	2,000	2,100	2,200	2,300	2,400
Total length LT [mm]	2,180	2,280	2,380	2,480	2,580	2,680	2,780	2,880	2,980
N [mm]	19	21	21	21	23	25	25	25	27
LA [mm]	2,114	2,214	2,314	2,414	2,514	2,614	2,714	2,814	2,914
LB [mm]	130	60	110	160	90	20	70	120	50
LC [mm]	1,920	2,160	2,160	2,160	2,400	2,640	2,640	2,640	2,880
A [mm]	2,113	2,213	2,313	2,413	2,513	2,613	2,713	2,813	2,913
B [mm]	840	840	840	840	840	1,080	1,080	1,080	1,080
Stage weight [kg]	62.6	64.9	67.2	69.5	71.8	74.1	76.4	78.7	81.0

LMSSA-20 dimensions, dual forcers

LMSSA-20S700, stroke length 940 – 1,840 mm

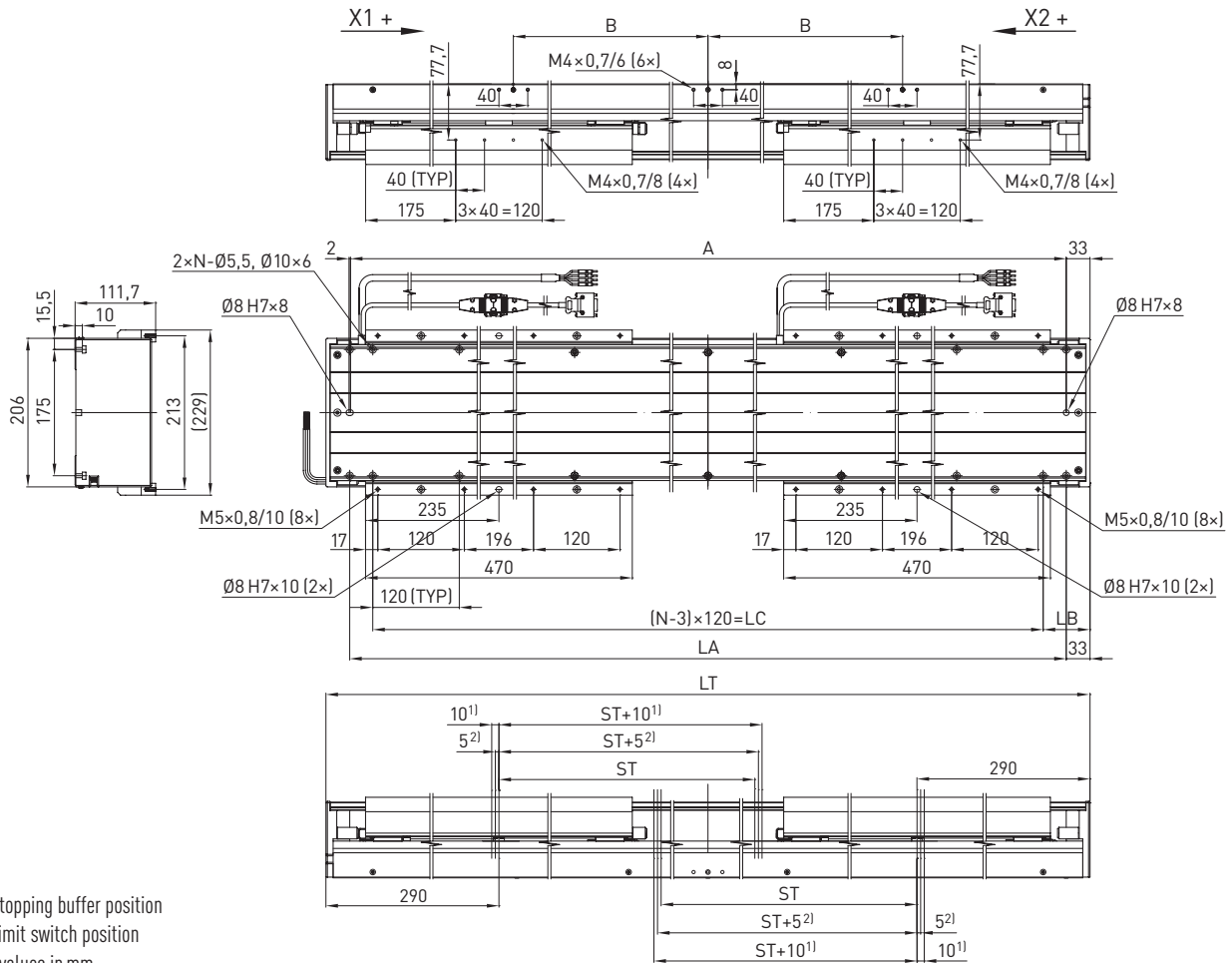

¹⁾ Stopping buffer position
²⁾ Limit switch position
All values in mm

Table 3.66 LMSSA-20S700 dimensions, dual forcers, stroke length 940 – 1,840 mm

Stroke length ST [mm]	940	990	1,040	1,090	1,140	1,190	1,240	1,290	1,340	1,440	1,540	1,640	1,740	1,840
Total length LT [mm]	2,030	2,080	2,130	2,180	2,230	2,280	2,330	2,380	2,430	2,530	2,630	2,730	2,830	2,930
N [mm]	19	19	19	19	19	21	21	21	21	23	23	25	25	25
LA [mm]	1,964	2,014	2,064	2,114	2,164	2,214	2,264	2,314	2,364	2,464	2,564	2,664	2,764	2,864
LB [mm]	55	80	105	130	155	60	85	110	135	65	115	45	95	145
LC [mm]	1,920	1,920	1,920	1,920	1,920	2,160	2,160	2,160	2,160	2,400	2,400	2,640	2,640	2,640
A [mm]	1,963	2,013	2,063	2,113	2,163	2,213	2,263	2,313	2,363	2,463	2,563	2,663	2,763	2,863
B [mm]	600	600	600	840	840	840	840	840	840	840	840	1,080	1,080	1,080
Stage weight [kg]	69.6	71.8	72.9	74.1	75.2	76.4	77.5	78.6	79.8	82.1	84.4	86.7	89.0	91.3

Linear Motor Systems

Linear motor axis LMX1A

4. Linear motor axis LMX1A

4.1 Properties of the LMX1A linear motor axes

LMX1A linear motor axes are equipped with an iron-core motor, which provides substantial continuous force. They can also be used in cross tables. The stroke length is measured via the optical or magnetic distance measuring systems incrementally or absolutely. The LMX1A linear motor axes have a very compact design and are available in overall lengths up to 4,000 mm.

- Max. acceleration 50 m/s²
- Max. speed 5 m/s
- Up to 4,000 mm long



4.2 Order code for LMX1A linear motor axes

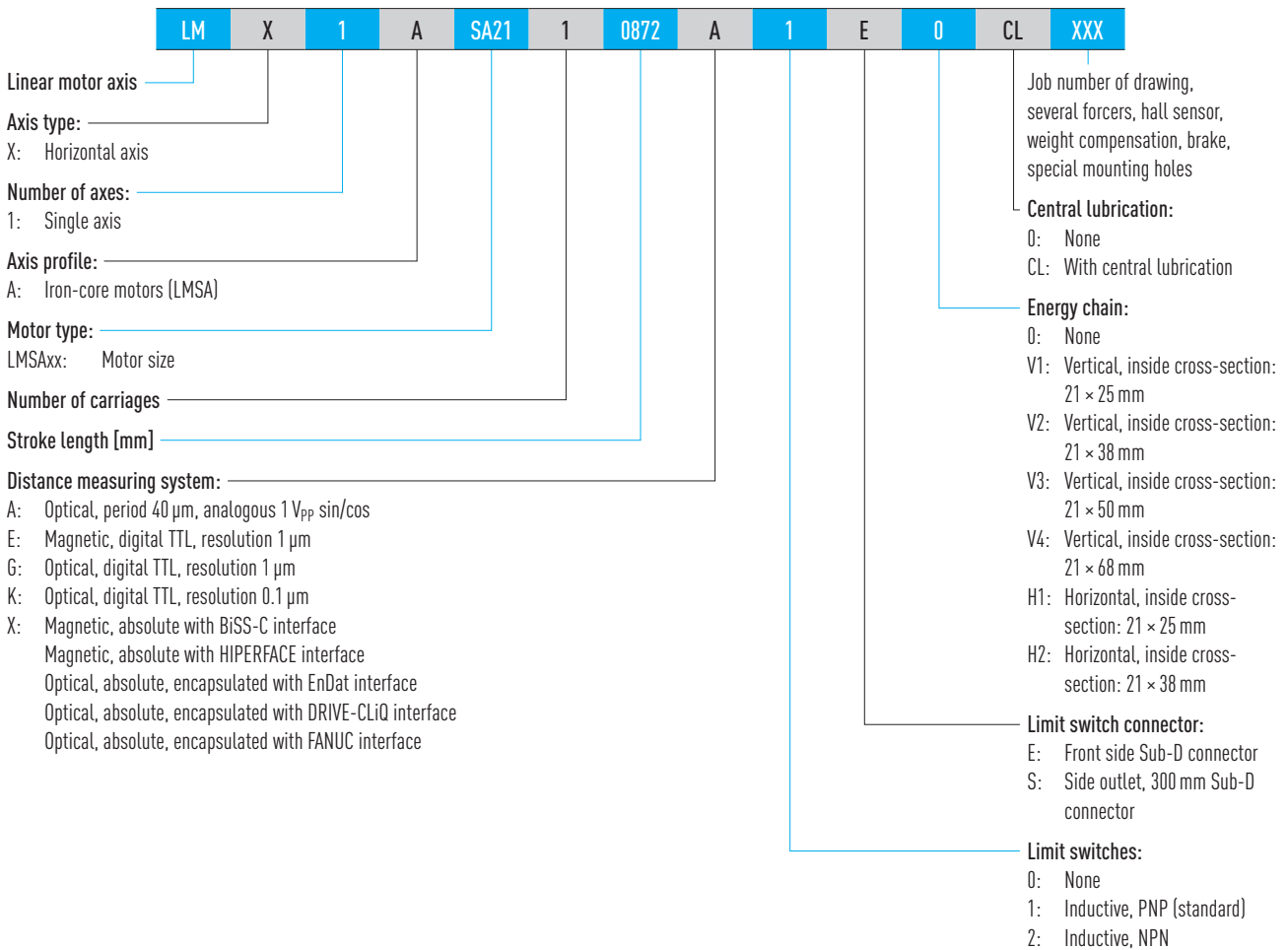

4.3 Energy supply for linear motor axes LMX1A

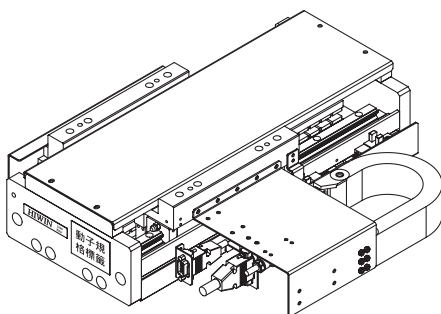

Energy supply horizontal

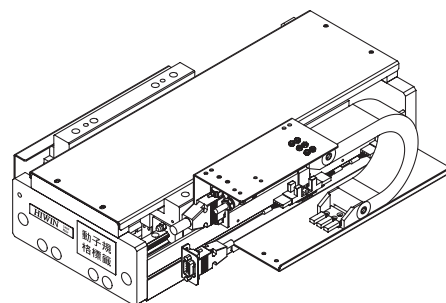

Energy supply vertical

4.4 Linear motor axis LMX1A specifications

4.4.1 Specifications LMX1A-SA11/SA12/SA13

Force as a function speed (DC bus voltage: 600 VDC)

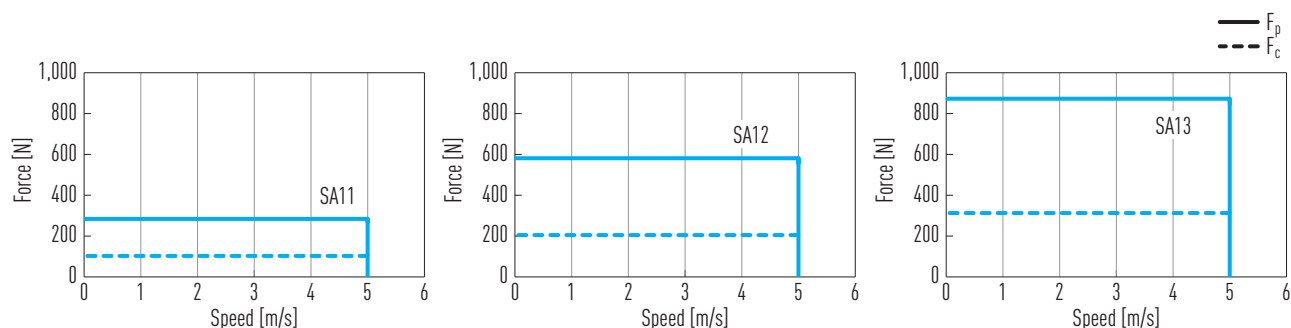

Acceleration as a function of load capacity (DC bus voltage: 600 VDC)

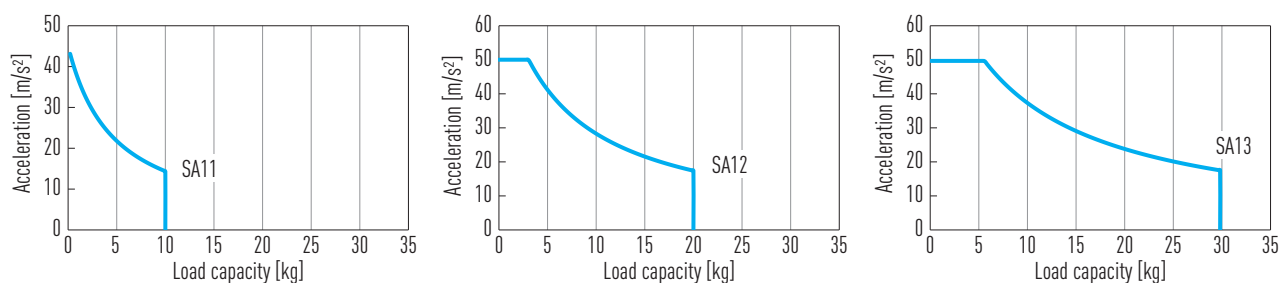

Table 4.1 Technical data LMX1A-SA11/SA12/SA13

	Symbol	Unit	LMX1A-SA11	LMX1A-SA12	LMX1A-SA13
Continuous force ¹⁾	F_c	N	103	205	308
Peek force ¹⁾	F_p	N	289	579	868
Stroke length		mm	100 – 4,000		
Resolution distance measuring system			Type E/G: 1 μ m; Type K: 0.1 μ m; Type A: 1 V_{SS}		
Repeatability		μ m	Type E/G: ± 1 ; Type K: ± 0.5 ; Type A: ± 1		
Accuracy		μ m	Type E/G: ± 2 ; Type K: ± 1 ; Type A: ± 2		
Horizontal straightness		μ m	10/500 mm		
Vertical straightness		μ m	20/500 mm		
Moved mass		kg	5	6	8
Typical load capacity		kg	10	20	30

¹⁾ F_c : 100 % duty cycle, at 120 °C winding temperature; F_p : 1 s

Electrical parameters of linear motors: see catalogue "Linear Motors and Distance Measuring Systems"

Linear Motor Systems

Linear motor axis LMX1A

4.4.2 LMX1A-SA11/SA12/SA13 dimensions

Table 4.2 LMX1A-SA11 dimensions (dimensional drawings see Page 63)

Stroke length	100	200	300	400	500	600	700	800	900	1,000
N	4	4	4	5	6	6	7	8	8	9
Total length LT [mm]	400	500	600	700	800	900	1,000	1,100	1,200	1,300
LA [mm]	25	25	65	75	25	75	50	25	75	50
LB [mm]	—	—	—	—	750	750	900	1,050	1,050	1,200
LC [mm]	100	100	100	150	—	—	—	—	—	—
LC with energy chain V1/V2 [mm] ¹⁾	65									
LC with energy chain V3/V4 [mm] ¹⁾	95									
LD [mm]	150	250	270	250	—	—	—	—	—	—

¹⁾ Dimension LC is determined by energy chain inside cross-section (see order code on Page 60)

Table 4.3 LMX1A-SA12 dimensions (dimensional drawings see Page 64)

Stroke length	100	200	300	400	500	600	700	800	900	1,000
N	4	4	4	6	6	7	8	8	9	10
Total length LT [mm]	500	600	700	800	900	1,000	1,100	1,200	1,300	1,400
LA [mm]	25	65	75	25	75	50	25	75	50	25
LB [mm]	—	—	—	750	750	900	1,050	1,050	1,200	1,350
LC [mm]	100	100	150	—	—	—	—	—	—	—
LC with energy chain V1/V2 [mm] ¹⁾	65									
LC with energy chain V3/V4 [mm] ¹⁾	95									
LD [mm]	250	270	250	—	—	—	—	—	—	—

¹⁾ Dimension LC is determined by energy chain inside cross-section (see order code on Page 60)

Table 4.4 LMX1A-SA13 dimensions (dimensional drawings see Page 65)

Stroke length	100	200	300	400	500	600	700	800	900	1,000
N	4	4	6	6	7	8	8	9	10	10
Total length LT [mm]	600	700	800	900	1,000	1,100	1,200	1,300	1,400	1,500
LA [mm]	65	75	25	75	50	25	75	50	25	75
LB [mm]	—	—	750	750	900	1,050	1,050	1,200	1,350	1,350
LC [mm]	100	150	—	—	—	—	—	—	—	—
LC with energy chain V1/V2 [mm] ¹⁾	65									
LC with energy chain V3/V4 [mm] ¹⁾	95									
LD [mm]	270	250	—	—	—	—	—	—	—	—

¹⁾ Dimension LC is determined by energy chain inside cross-section (see order code on Page 60)

Dimensional drawings LMX1A-SA11

Without energy supply

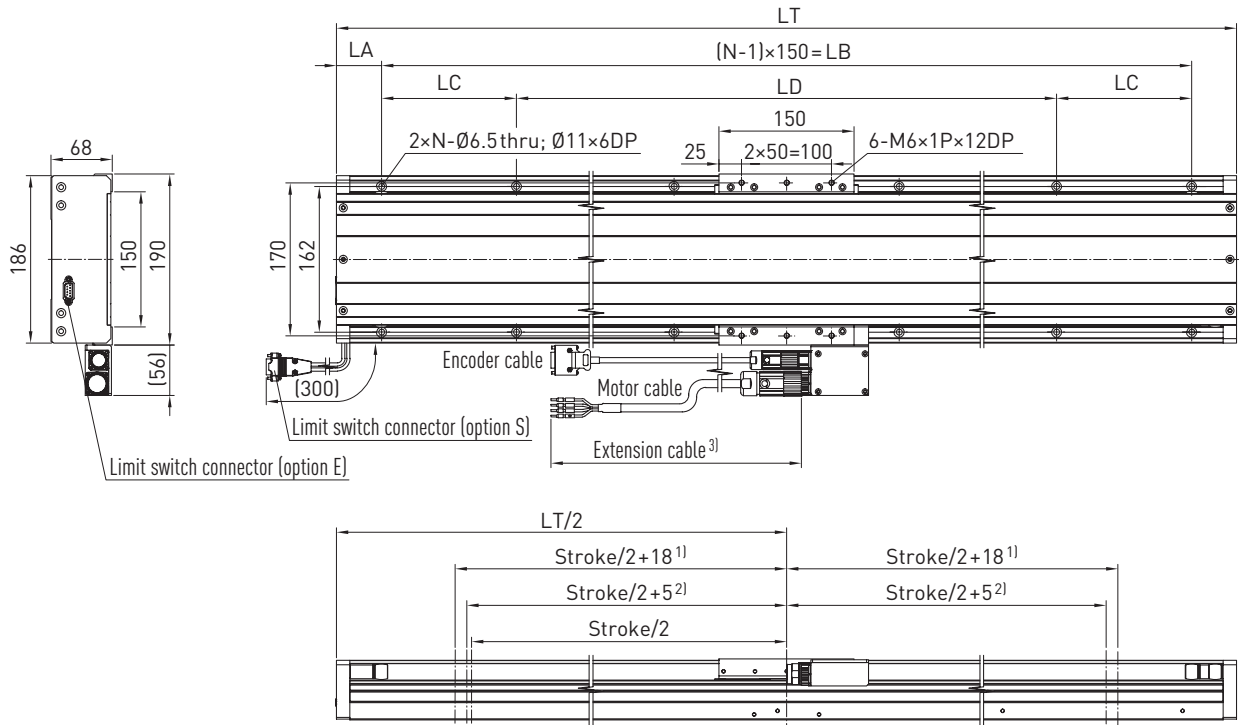

¹⁾ Stopping buffer position

²⁾ Limit switch position

Energy supply horizontal

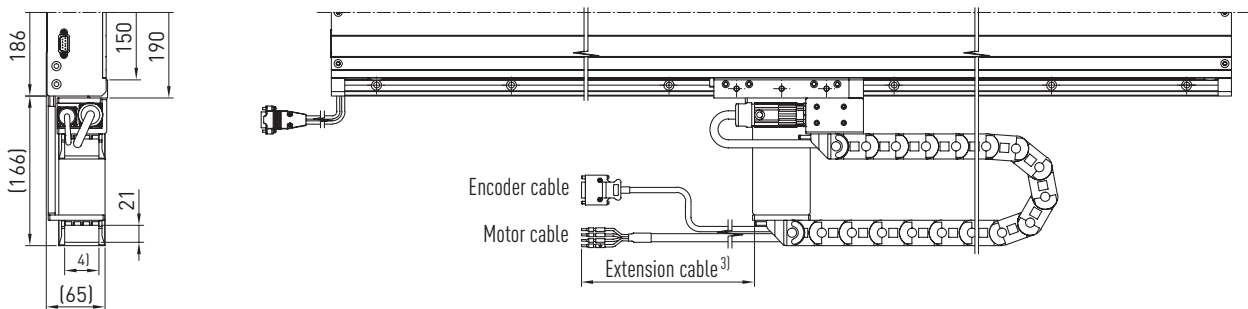

Energy supply vertical

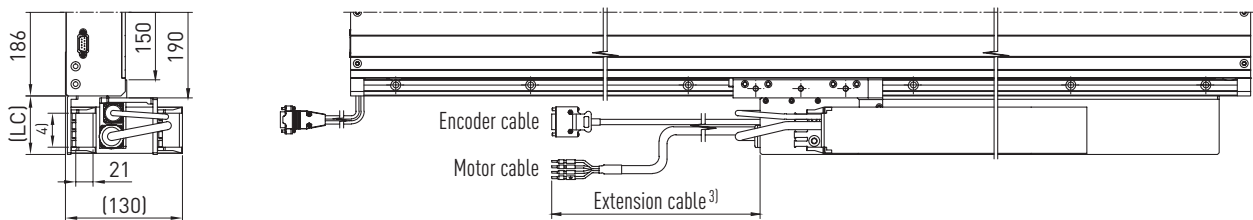

³⁾ Optional

⁴⁾ Inside width of energy chain: see order code on [Page 60](#)

All values in mm

Linear Motor Systems

Linear motor axis LMX1A

Dimensional drawings LMX1A-SA12

Without energy supply

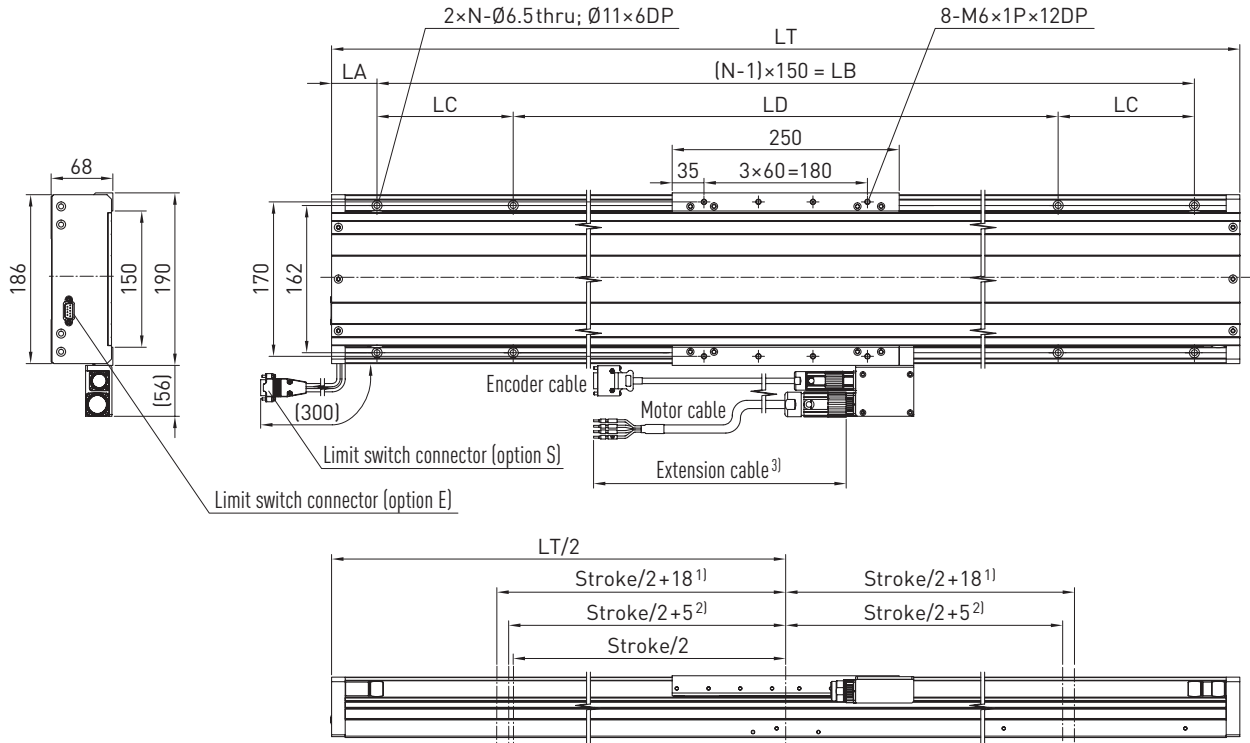

¹ Stopping buffer position

² Limit switch position

Energy supply horizontal

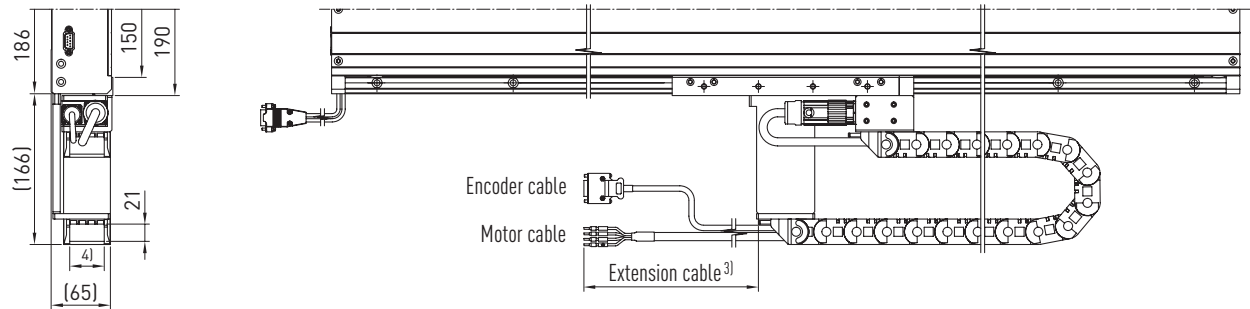

Energy supply vertical

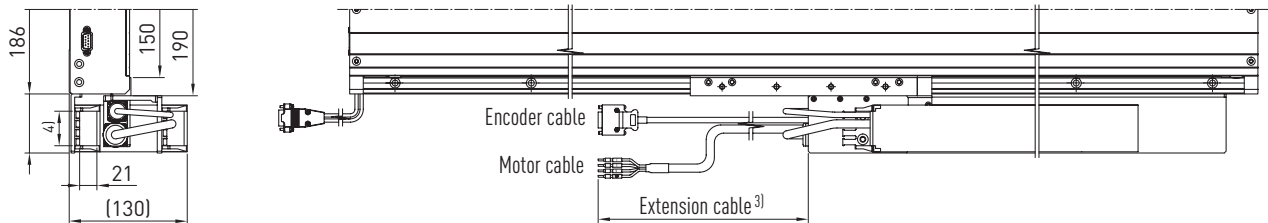

³ Optional

⁴ Inside width of energy chain: see order code on [Page 60](#)

All values in mm

Dimensional drawings LMX1A-SA13

Without energy supply

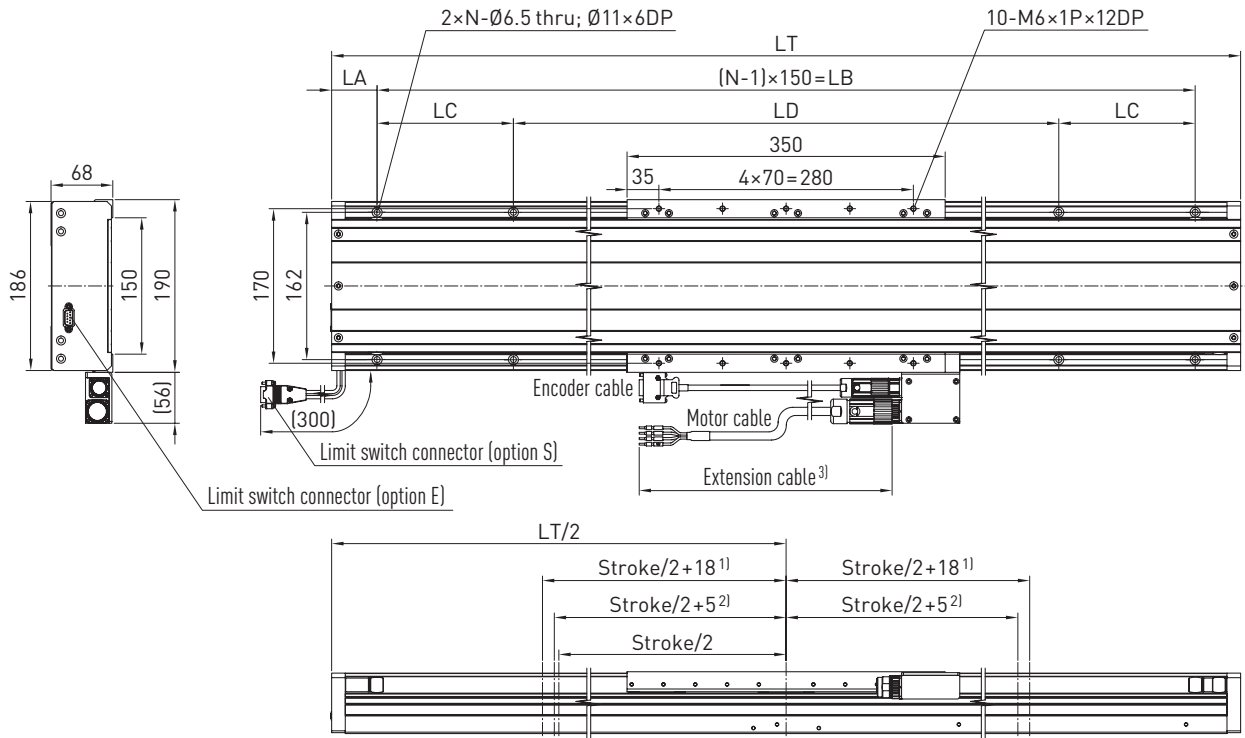

¹⁾ Stopping buffer position

²⁾ Limit switch position

Energy supply horizontal

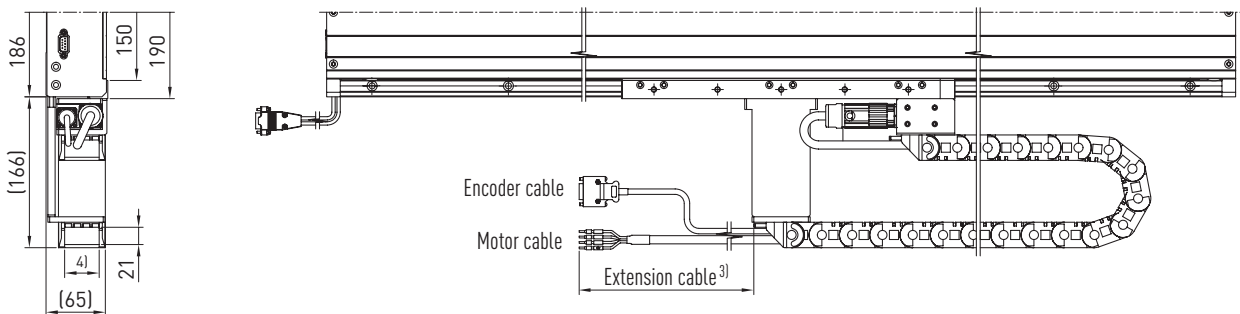

Energy supply vertical

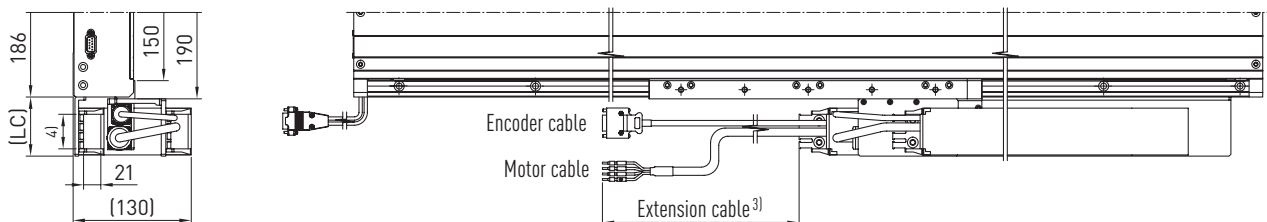

³⁾ Optional

⁴⁾ Inside width of energy chain: see order code on [Page 60](#)

All values in mm

Linear Motor Systems

Linear motor axis LMX1A

4.4.3 Specifications LMX1A-SA21/SA22/SA23

Force as a function speed (DC bus voltage: 600 VDC)

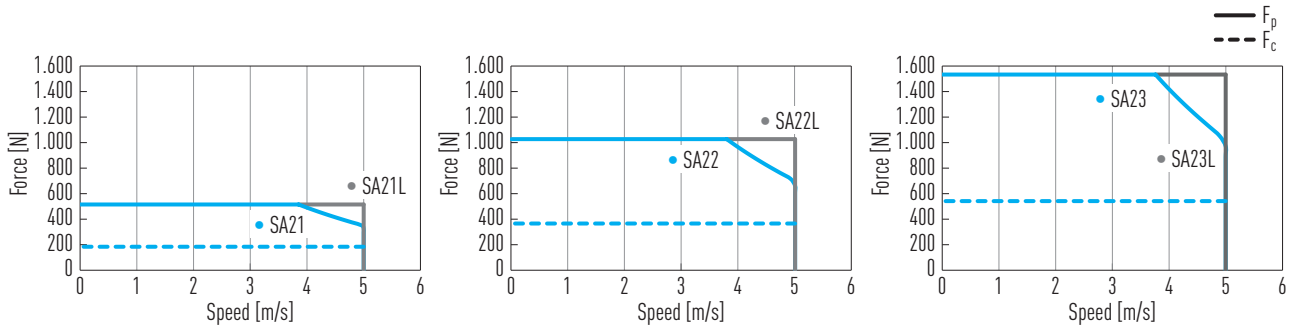

Acceleration as a function of load capacity (DC bus voltage: 600 VDC)

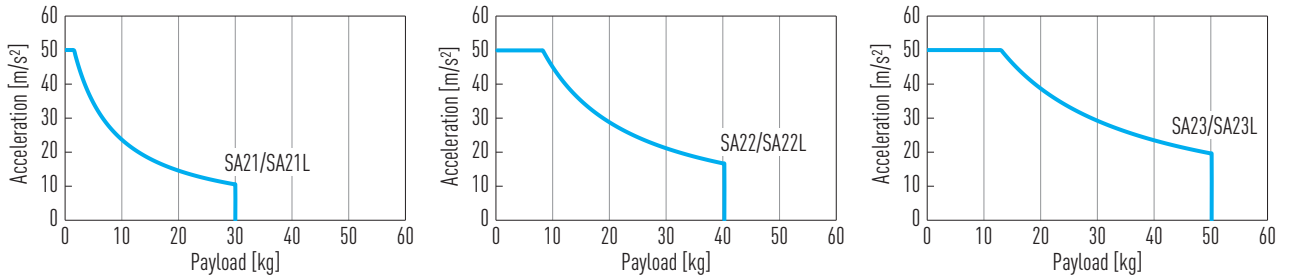

Table 4.5 Technical data LMX1A-SA21/SA22/SA23

	Symbol	Unit	LMX1A-SA21(L)	LMX1A-SA22(L)	LMX1A-SA23(L)
Continuous force ¹⁾	F_c	N	181	362	544
Peek force ¹⁾	F_p	N	512	1,023	1,535
Stroke length		mm	100 – 4,000		
Resolution distance measuring system			Type E/G: 1 μm ; Type K: 0.1 μm ; Type A: 1 V_{SS}		
Repeatability		μm	Type E/G: ± 1 ; Type K: ± 0.5 ; Type A: ± 1		
Accuracy		μm	Type E/G: ± 2 ; Type K: ± 1 ; Type A: ± 2		
Horizontal straightness		μm	10/500 mm		
Vertical straightness		μm	20/500 mm		
Moved mass		kg	6	8	11
Typical load capacity		kg	30	40	50

¹⁾ F_c : 100 % duty cycle, at 120 °C winding temperature; F_p : 1 s

Electrical parameters of linear motors: see catalogue "Linear Motors and Distance Measuring Systems"

4.4.4 LMX1A-SA21/SA22/SA23 dimensions

Table 4.6 LMX1A-SA21 dimensions (dimensional drawings see Page 68)

Stroke length	100	200	300	400	500	600	700	800	900	1,000
N	4	4	4	5	6	6	7	8	8	9
Total length LT [mm]	400	500	600	700	800	900	1,000	1,100	1,200	1,300
LA [mm]	25	25	65	75	25	75	50	25	75	50
LB [mm]	—	—	—	—	750	750	900	1,050	1,050	1,200
LC [mm]	100	100	100	150	—	—	—	—	—	—
LC with energy chain V1/V2 [mm] ¹⁾	65									
LC with energy chain V3/V4 [mm] ¹⁾	95									
LD [mm]	150	250	270	250	—	—	—	—	—	—

¹⁾ Dimension LC is determined by energy chain inside cross-section (see order code on Page 60)

Table 4.7 LMX1A-SA22 dimensions (dimensional drawings see Page 69)

Stroke length	100	200	300	400	500	600	700	800	900	1,000
N	4	4	4	6	6	7	8	8	9	10
Total length LT [mm]	500	600	700	800	900	1,000	1,100	1,200	1,300	1,400
LA [mm]	25	65	75	25	75	50	25	75	50	25
LB [mm]	—	—	—	750	750	900	1,050	1,050	1,200	1,350
LC [mm]	100	100	150	—	—	—	—	—	—	—
LC with energy chain V1/V2 [mm] ¹⁾	65									
LC with energy chain V3/V4 [mm] ¹⁾	95									
LD [mm]	250	270	250	—	—	—	—	—	—	—

¹⁾ Dimension LC is determined by energy chain inside cross-section (see order code on Page 60)

Table 4.8 LMX1A-SA23 dimensions (dimensional drawings see Page 70)

Stroke length	100	200	300	400	500	600	700	800	900	1,000
N	4	4	6	6	7	8	8	9	10	10
Total length LT [mm]	600	700	800	900	1,000	1,100	1,200	1,300	1,400	1,500
LA [mm]	65	75	25	75	50	25	75	50	25	75
LB [mm]	—	—	750	750	900	1,050	1,050	1,200	1,350	1,350
LC [mm]	100	150	—	—	—	—	—	—	—	—
LC with energy chain V1/V2 [mm] ¹⁾	65									
LC with energy chain V3/V4 [mm] ¹⁾	95									
LD [mm]	270	250	—	—	—	—	—	—	—	—

¹⁾ Dimension LC is determined by energy chain inside cross-section (see order code on Page 60)

Linear Motor Systems

Linear motor axis LMX1A

Dimensional drawings LMX1A-SA21

Without energy supply

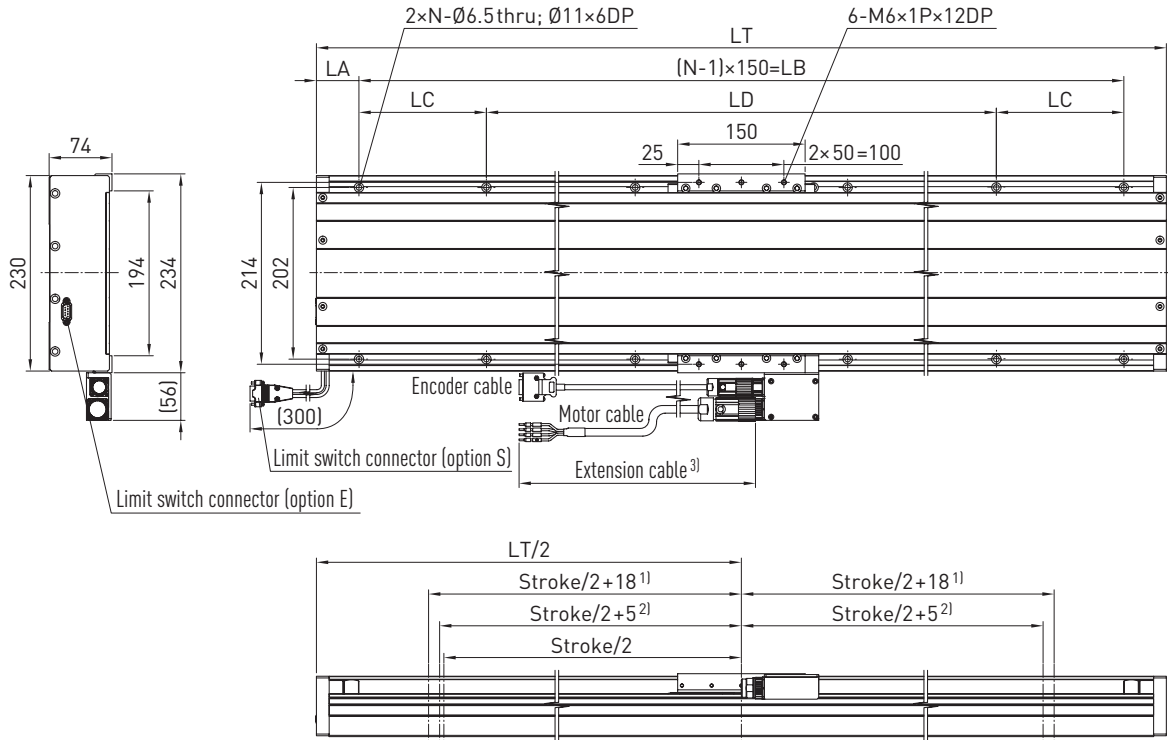

1) Stopping buffer position

2) Limit switch position

Energy supply horizontal

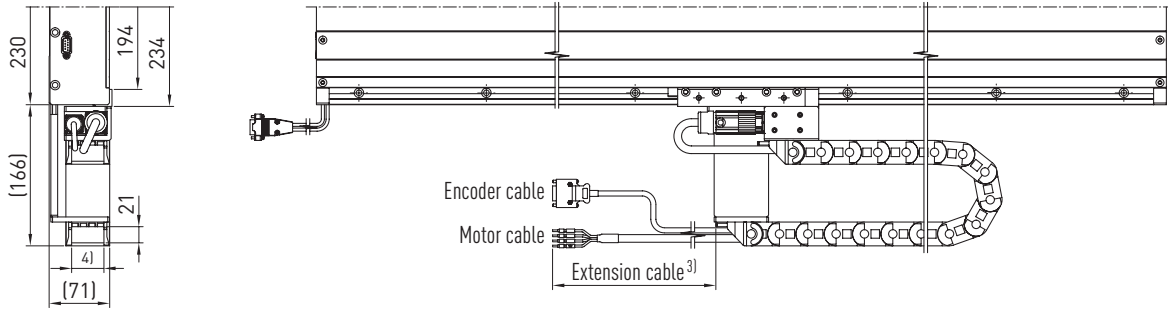

Energy supply vertical

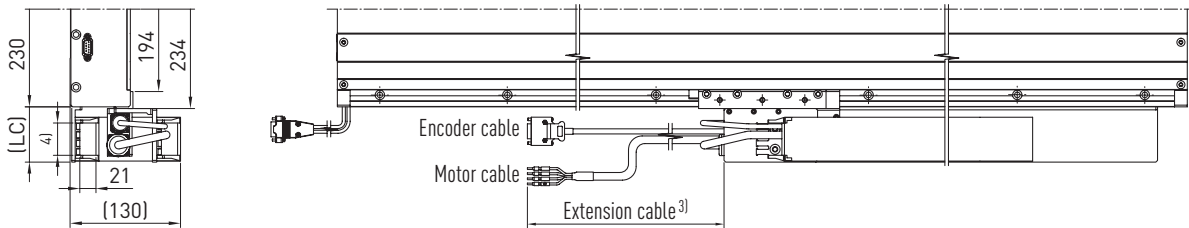

³) Optional

⁴) Inside width of energy chain: see order code on Page 60

All values in mm

Dimensional drawings LMX1A-SA22

Without energy supply

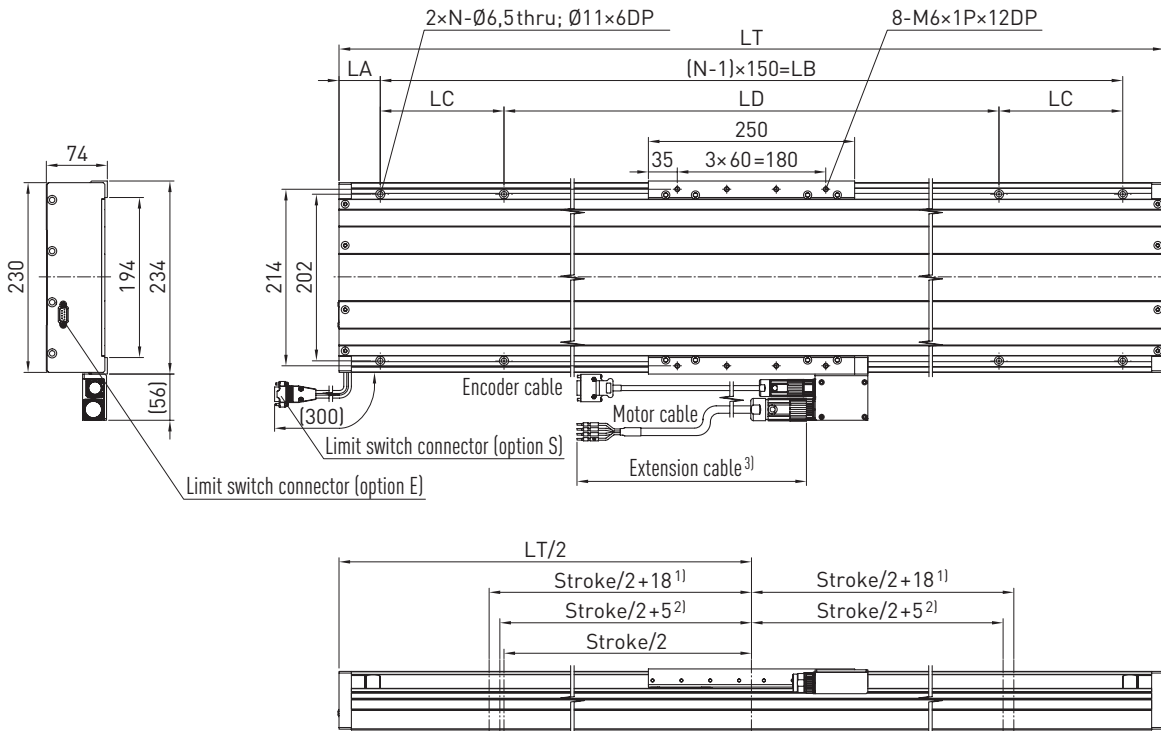

¹) Stopping buffer position

²) Limit switch position

Energy supply horizontal

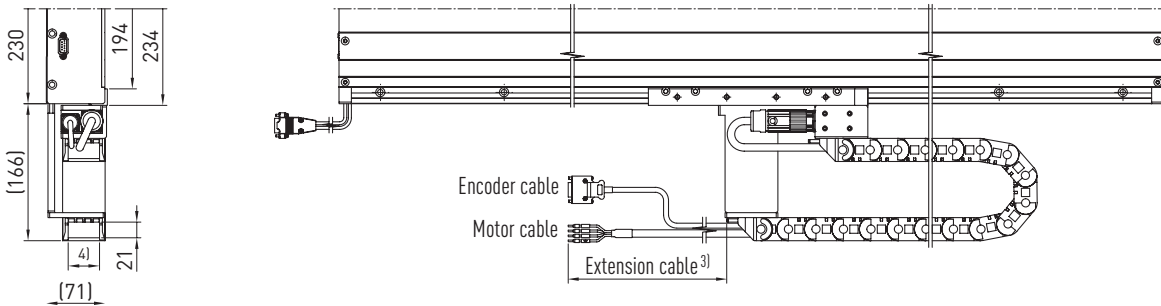

Energy supply vertical

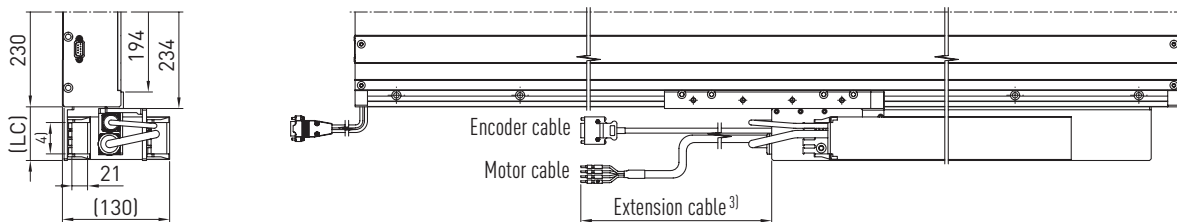

³) Optional

⁴) Inside width of energy chain: see order code on Page 60

All values in mm

Linear Motor Systems

Linear motor axis LMX1A

Dimensional drawings LMX1A-SA23

Without energy supply

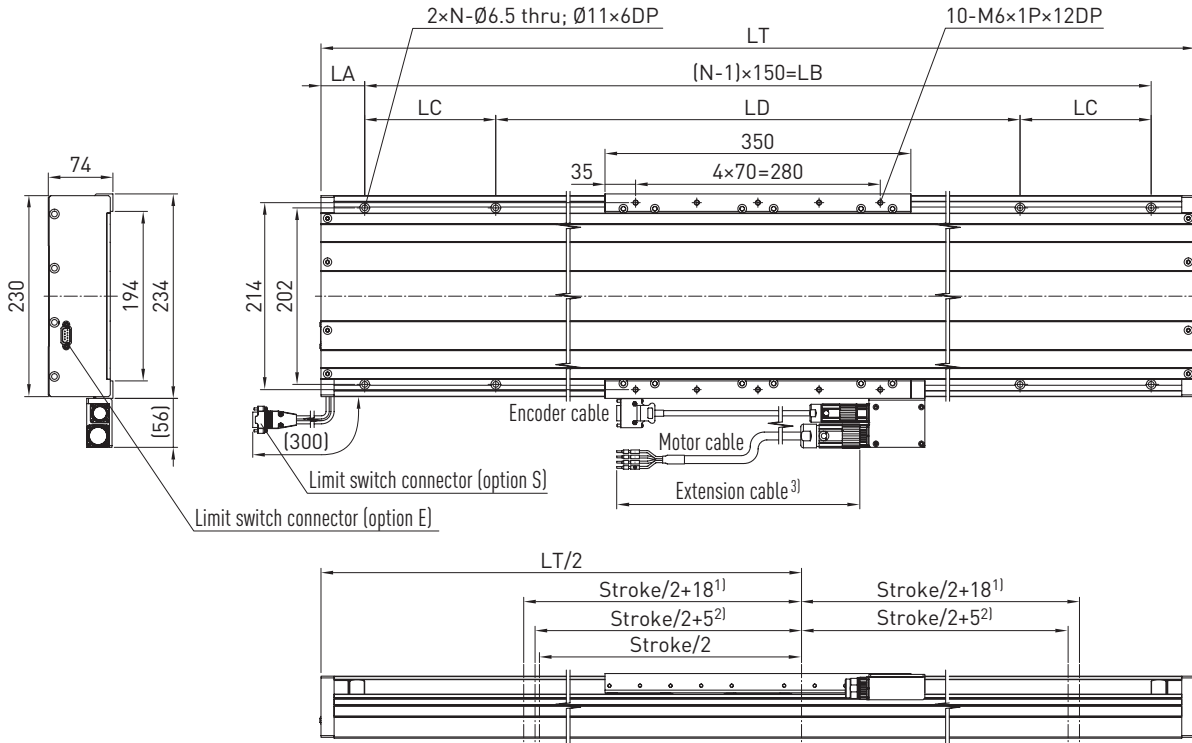

¹ Stopping buffer position

² Limit switch position

Energy supply horizontal

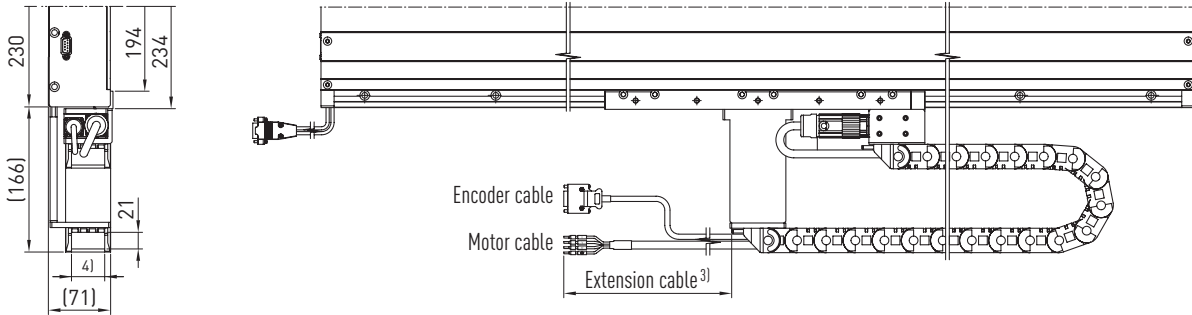

Energy supply vertical

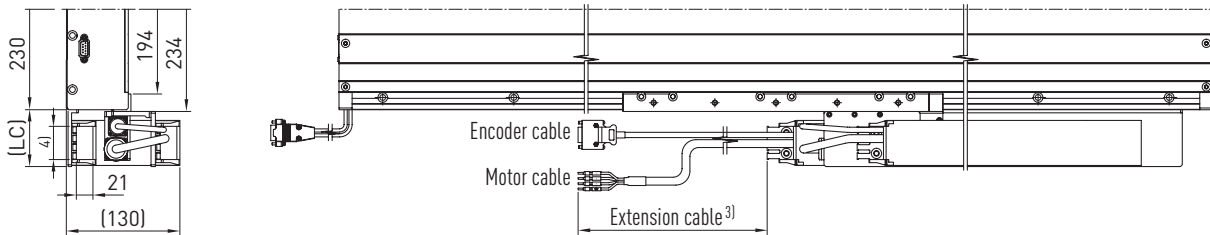

³ Optional

⁴ Inside width of energy chain: see order code on Page 60

All values in mm

4.4.5 Specifications LMX1A-SA31/SA32/SA33

Force as a function speed (DC bus voltage: 600 VDC)

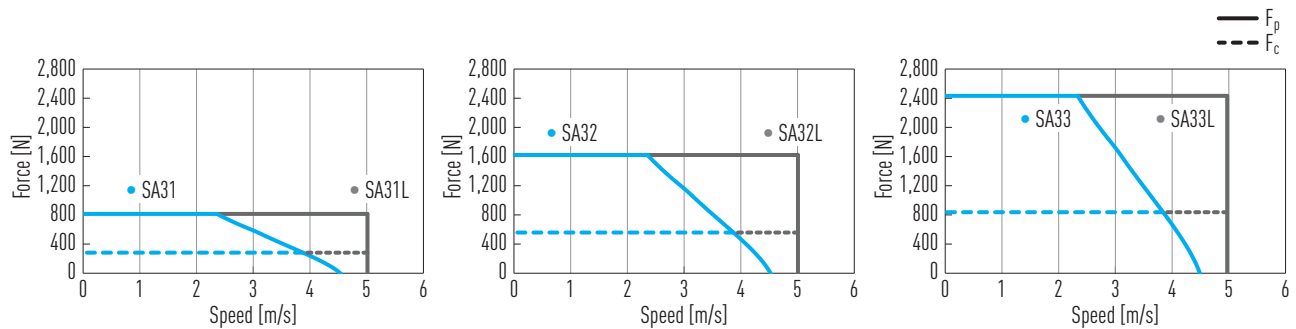

Acceleration as a function of load capacity (DC bus voltage: 600 VDC)

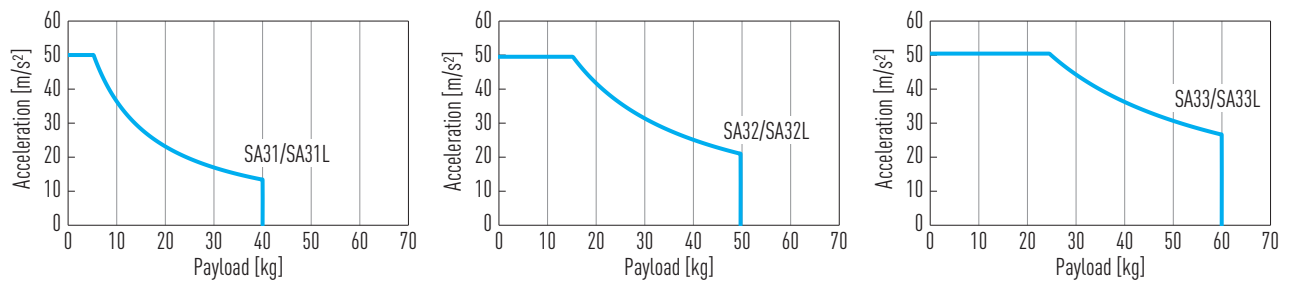

Table 4.9 Technical data LMX1A-SA31/SA32/SA33

	Symbol	Unit	LMX1A-SA31(L)	LMX1A-SA32(L)	LMX1A-SA33(L)
Continuous force ¹⁾	F_c	N	292	583	875
Peek force ¹⁾	F_p	N	823	1,646	2,469
Stroke length		mm	100 – 4,000		
Resolution distance measuring system			Type E/G: 1 μ m; Type K: 0.1 μ m; Type A: 1 V_{SS}		
Repeatability		μ m	Type E/G: ± 1 ; Type K: ± 0.5 ; Type A: ± 1		
Accuracy		μ m	Type E/G: ± 2 ; Type K: ± 1 ; Type A: ± 2		
Horizontal straightness		μ m	10/500 mm		
Vertical straightness		μ m	20/500 mm		
Moved mass		kg	7.5	10.5	14.5
Typical load capacity		kg	40	50	60

¹⁾ F_c : 100 % duty cycle, at 120 °C winding temperature; F_p : 1 s

Electrical parameters of linear motors: see catalogue "Linear Motors and Distance Measuring Systems"

Linear Motor Systems

Linear motor axis LMX1A

4.4.6 LMX1A-SA31/SA32/SA33 dimensions

Table 4.10 LMX1A-SA31 dimensions (dimensional drawings see Page 73)

Stroke length	100	200	300	400	500	600	700	800	900	1,000
N	4	4	4	5	6	6	7	8	8	9
Total length LT [mm]	400	500	600	700	800	900	1,000	1,100	1,200	1,300
LA [mm]	25	25	65	75	25	75	50	25	75	50
LB [mm]	—	—	—	—	750	750	900	1,050	1,050	1,200
LC [mm]	100	100	100	150	—	—	—	—	—	—
LC with energy chain V1/V2 [mm] ¹⁾	65									
LC with energy chain V3/V4 [mm] ¹⁾	95									
LD [mm]	150	250	270	250	—	—	—	—	—	—

¹⁾ Dimension LC is determined by energy chain inside cross-section (see order code on Page 60)

Table 4.11 LMX1A-SA32 dimensions (dimensional drawings see Page 74)

Stroke length	100	200	300	400	500	600	700	800	900	1,000
N	4	4	4	6	6	7	8	8	9	10
Total length LT [mm]	500	600	700	800	900	1,000	1,100	1,200	1,300	1,400
LA [mm]	25	65	75	25	75	50	25	75	50	25
LB [mm]	—	—	—	750	750	900	1,050	1,050	1,200	1,350
LC [mm]	100	100	150	—	—	—	—	—	—	—
LC with energy chain V1/V2 [mm] ¹⁾	65									
LC with energy chain V3/V4 [mm] ¹⁾	95									
LD [mm]	250	270	250	—	—	—	—	—	—	—

¹⁾ Dimension LC is determined by energy chain inside cross-section (see order code on Page 60)

Table 4.12 LMX1A-SA33 dimensions (dimensional drawings see Page 75)

Stroke length	100	200	300	400	500	600	700	800	900	1,000
N	4	4	6	6	7	8	8	9	10	10
Total length LT [mm]	600	700	800	900	1,000	1,100	1,200	1,300	1,400	1,500
LA [mm]	65	75	25	75	50	25	75	50	25	75
LB [mm]	—	—	750	750	900	1,050	1,050	1,200	1,350	1,350
LC [mm]	100	150	—	—	—	—	—	—	—	—
LC with energy chain V1/V2 [mm] ¹⁾	65									
LC with energy chain V3/V4 [mm] ¹⁾	95									
LD [mm]	270	250	—	—	—	—	—	—	—	—

¹⁾ Dimension LC is determined by energy chain inside cross-section (see order code on Page 60)

Dimensional drawings LMX1A-SA31

Without energy supply

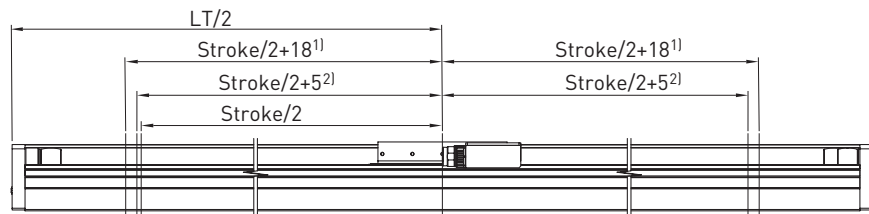
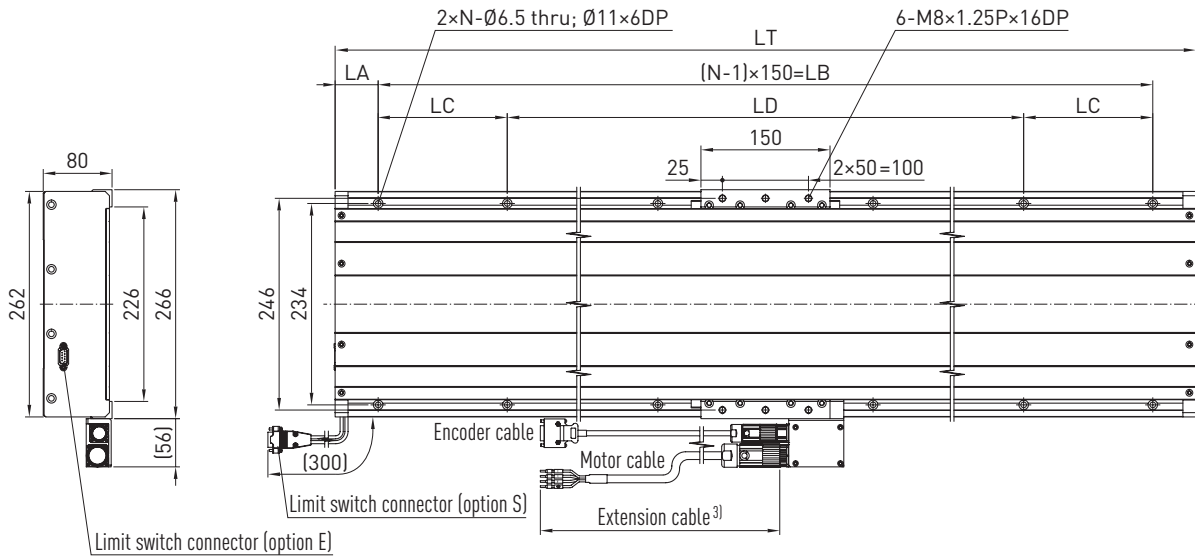

- ¹) Stopping buffer position
- ²) Limit switch position

Energy supply horizontal

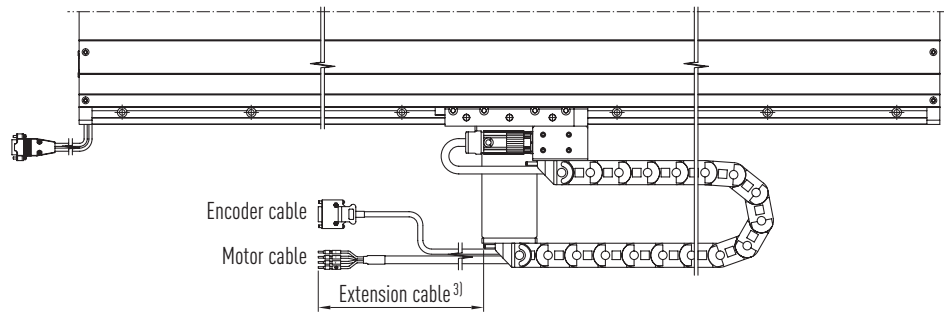
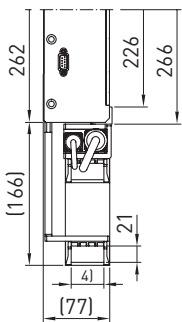

Energy supply vertical

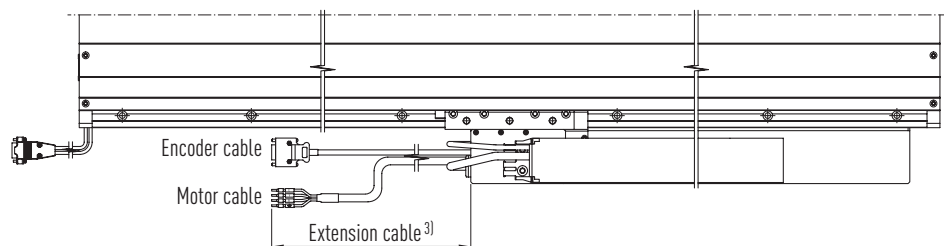
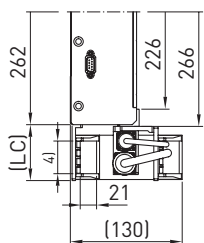

- ³) Optional
- ⁴) Inside width of energy chain: see order code on [Page 60](#)

All values in mm

Linear Motor Systems

Linear motor axis LMX1A

Dimensional drawings LMX1A-SA32

Without energy supply

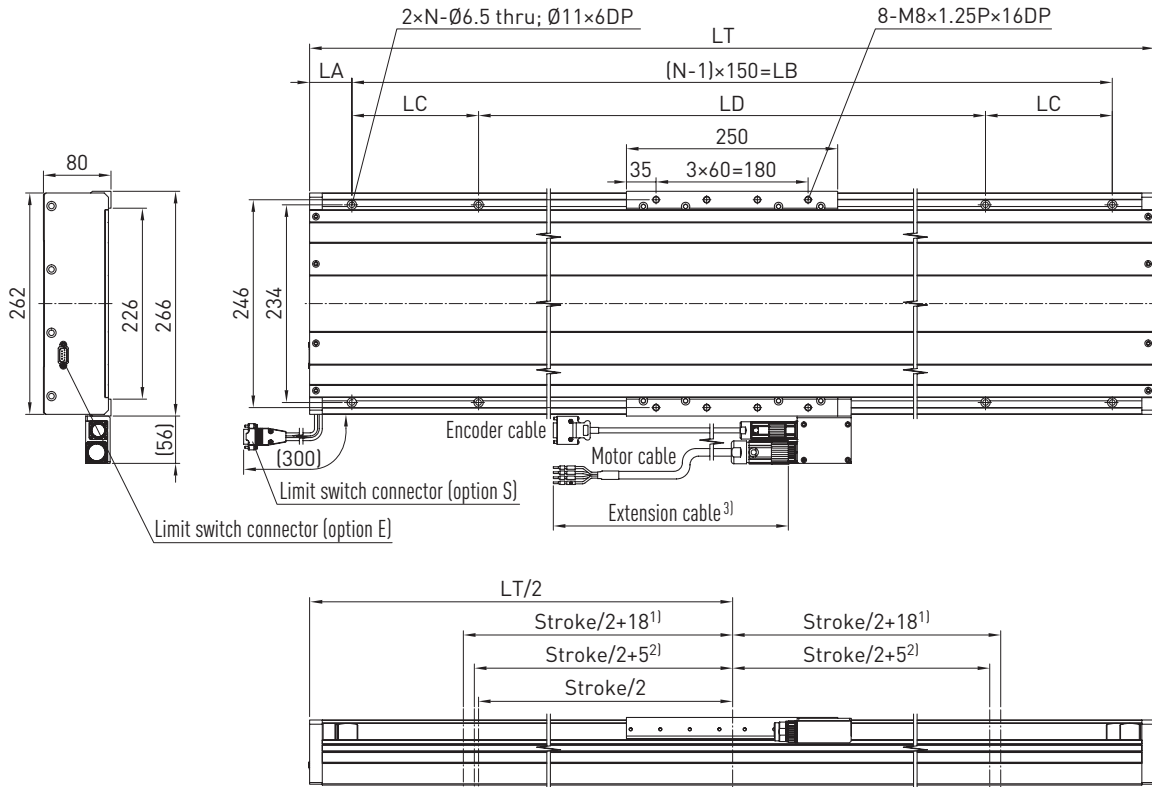

¹⁾ Stopping buffer position

²⁾ Limit switch position

Energy supply horizontal

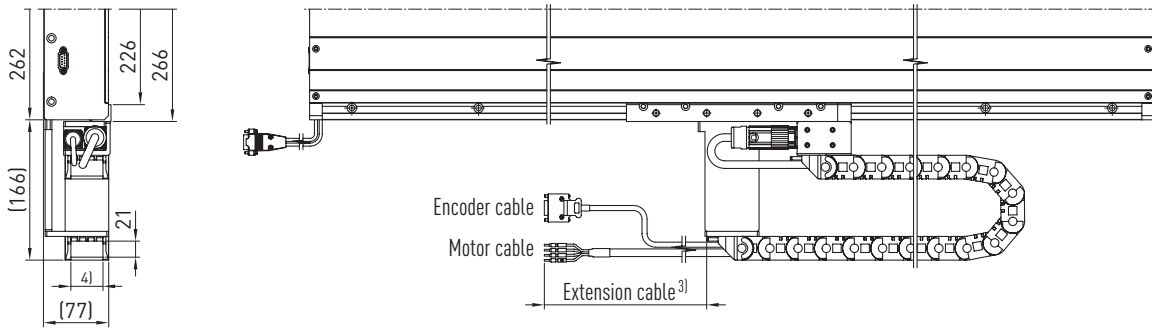

Energy supply vertical

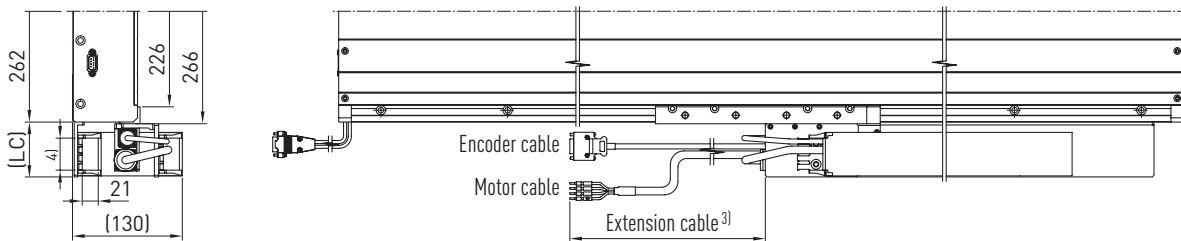

³⁾ Optional

⁴⁾ Inside width of energy chain: see order code on [Page 60](#)

All values in mm

Dimensional drawings LMX1A-SA33

Without energy supply

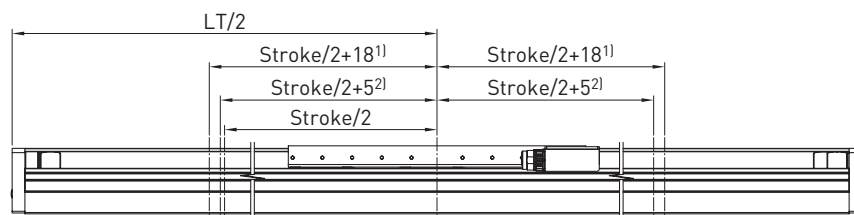
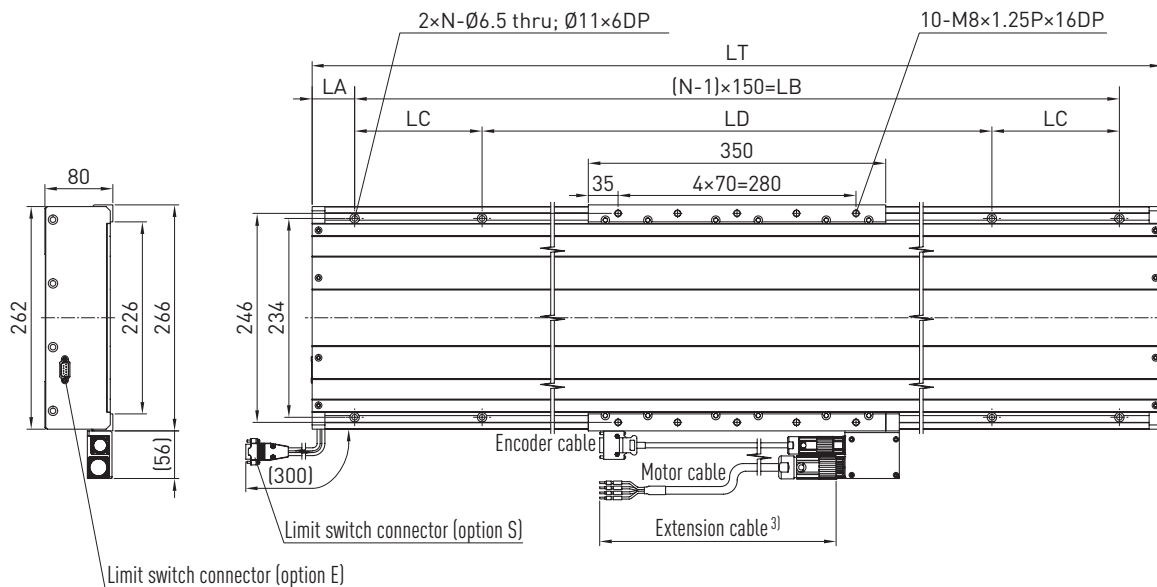

- 1) Stopping buffer position
- 2) Limit switch position

Energy supply horizontal

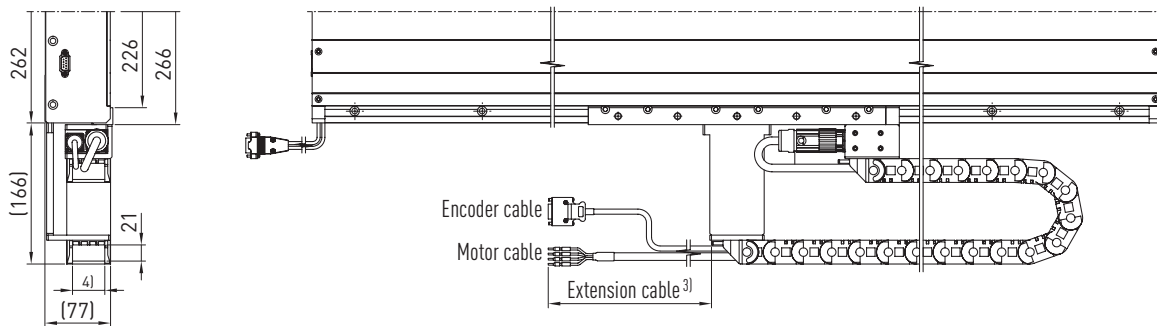

Energy supply vertical

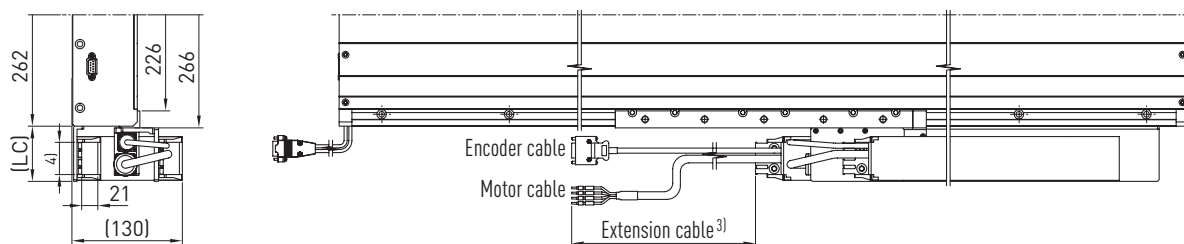

- 3) Optional
- 4) Inside width of energy chain: see order code on [Page 60](#)

All values in mm

Linear Motor Systems

Linear motor axis LMX1E

5. Linear motor axis LMX1E

5.1 Properties of the LMX1E linear motor axes

LMX1E linear motor axes are equipped with a coreless motor and are well suited for applications with a high degree of synchronous operational requirements. They can also be used in cross tables. They are distinguished by their very flat design. The stroke length is measured incrementally or absolutely via optical encoders. The LMX1E linear motor axes have very high dynamics and are available in overall lengths up to 4,000 mm.

- Max. acceleration 100 m/s²
- Max. speed 5 m/s
- Up to 4,000 mm long



5.2 Order code for LMX1E linear motor axes

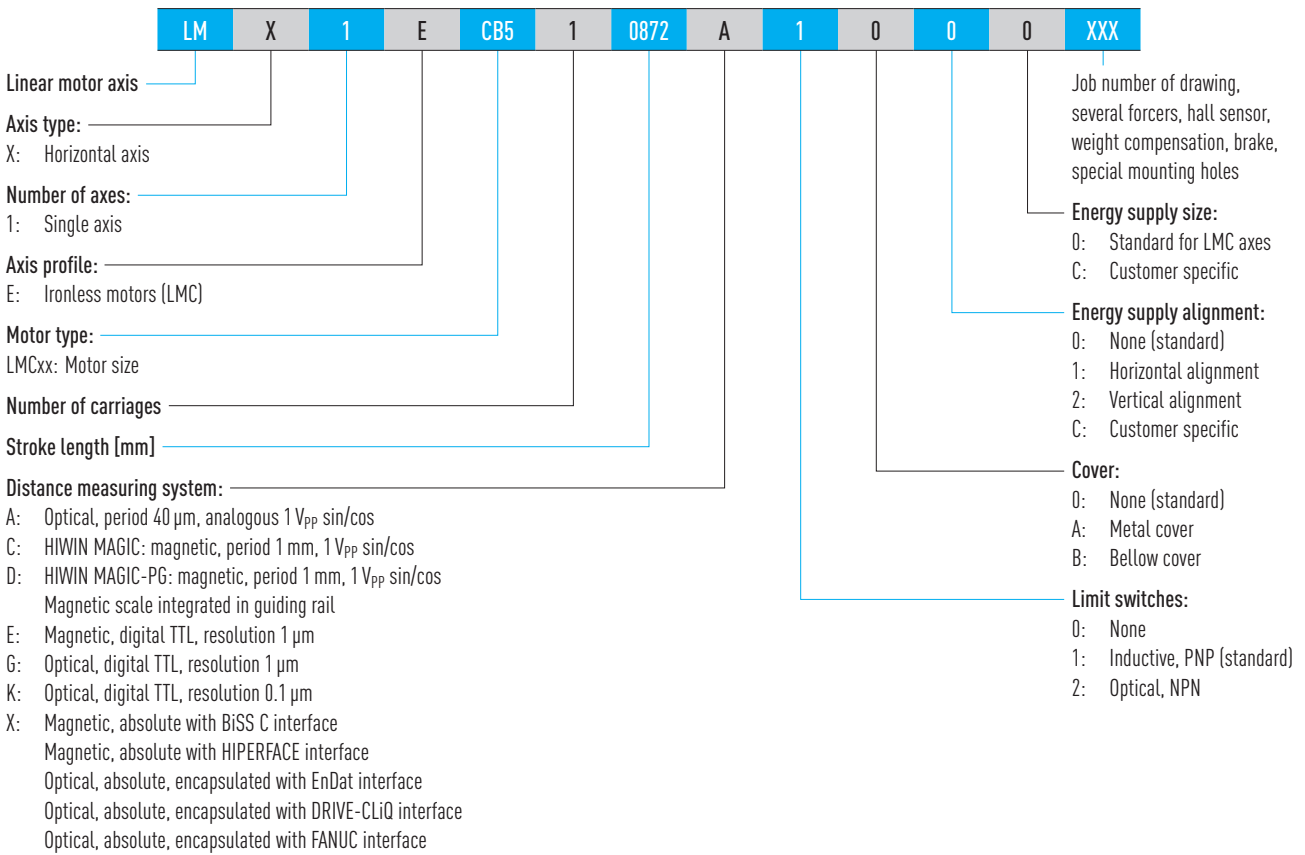

5.3 Energy supply for linear motor axes LMX1A

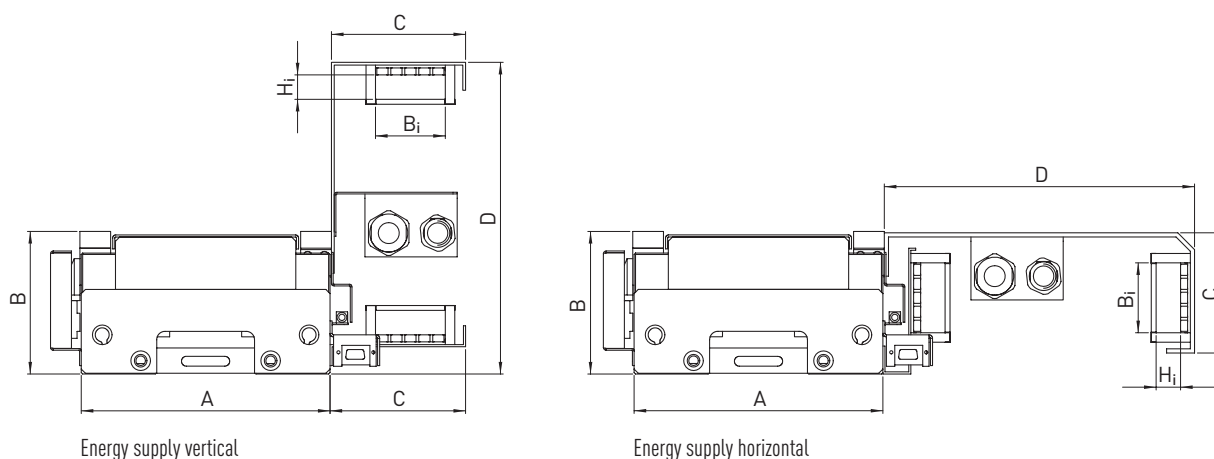

Table 5.1 Dimensions of energy supply

Energy supply alignment	C [mm]	D [mm]	Internal dimensions B _i × H _i [mm]
Vertical	97	170	50 × 21
Horizontal	79	170	50 × 21

5.4 Linear motor axis LMX1E specifications

Table 5.2 Technical data of LMX1E linear motor axes

Description (order code) xxxx = travel distance [mm]	Motor type	F _c [N]	F _p [N]	Weight of carriage [kg]	Length of carriage [mm]	v _{max} [m/s]	a _{max} [m/s ²]	Dimension A [mm]	Dimension B [mm]
LMX1E-CB5-1-xxxx-C100	LMCB5	91	364	2.3	180	5	100	178	80
LMX1E-CB6-1-xxxx-C100	LMCB6	109	436	3.3	210	5	100	178	80
LMX1E-CB7-1-xxxx-C100	LMCB7	128	512	3.8	240	5	100	178	80
LMX1E-CB8-1-xxxx-C100	LMCB8	145	580	4.5	280	5	100	178	80
LMX1E-CB5-1-xxxx-C1A0	LMCB5	91	364	2.5	180	5	100	178	95/105 ¹⁾
LMX1E-CB6-1-xxxx-C1A0	LMCB6	109	436	3.5	210	5	100	178	95/105 ¹⁾
LMX1E-CB7-1-xxxx-C1A0	LMCB7	128	512	4.0	240	5	100	178	95/105 ¹⁾
LMX1E-CB8-1-xxxx-C1A0	LMCB8	145	580	4.7	280	5	100	178	95/105 ¹⁾

F_c = Continuous power, 100 % duty cycle, at 100 °C winding temperature

F_p = Peak force (1 s)

Electrical parameters for linear motors see catalogue "Linear Motors and Distance Measuring Systems"

¹⁾ See dimensional tables Page 82 till Page 85

Linear Motor Systems

Linear motor axis LMX1E

5.4.1 LMX1E linear motor axes without cover

Dimensions and weights of the LMX1E-CB5 linear motor axis without cover

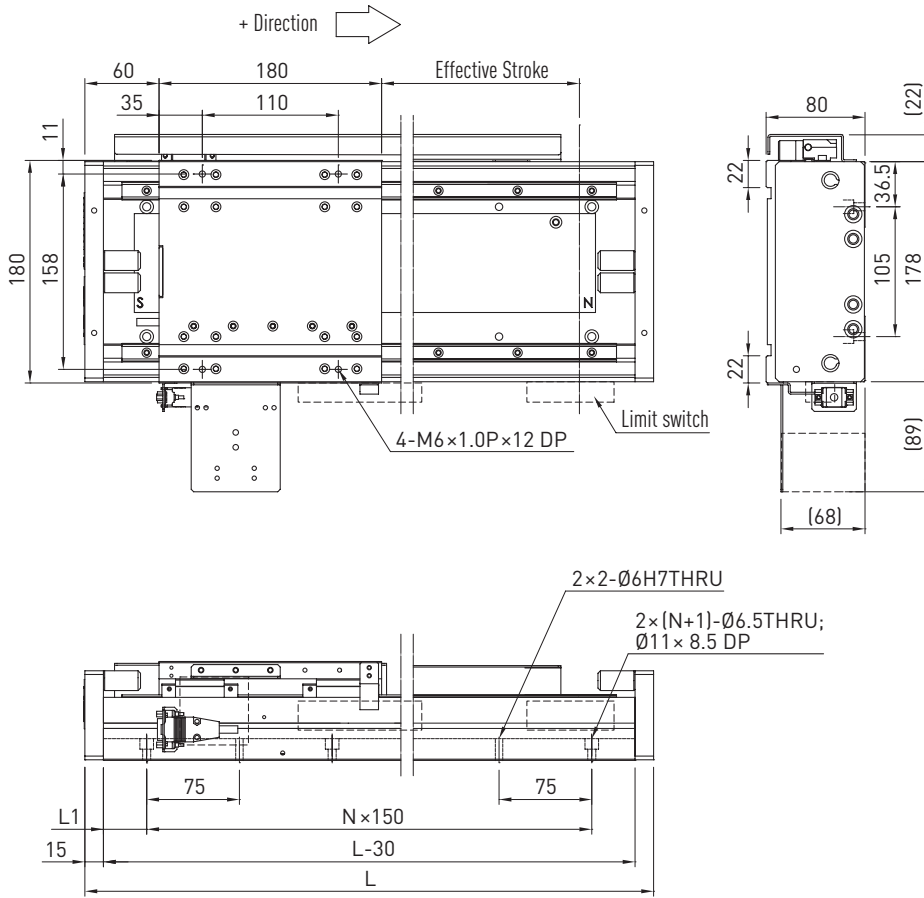

All values in mm

Table 5.3 Dimensions and weights of LMX1E-CB5 without cover

Stroke length [mm]	100	200	300	400	500	600	700	800	900	1,000	1,100	1,200
Total length L [mm]	400	500	600	700	800	900	1,000	1,100	1,200	1,300	1,400	1,500
L1 [mm]	35	85	60	35	85	60	35	85	60	35	85	60
N	1 ¹⁾	2	3	4	4	5	6	6	7	8	8	9
Weight [kg]	18	22	26	30	34	38	42	46	50	54	58	62

¹⁾ When stroke length = 100 mm the mounting hole distance increases from 150 to 300 mm

Dimensions and weights of the LMX1E-CB6 linear motor axis without cover

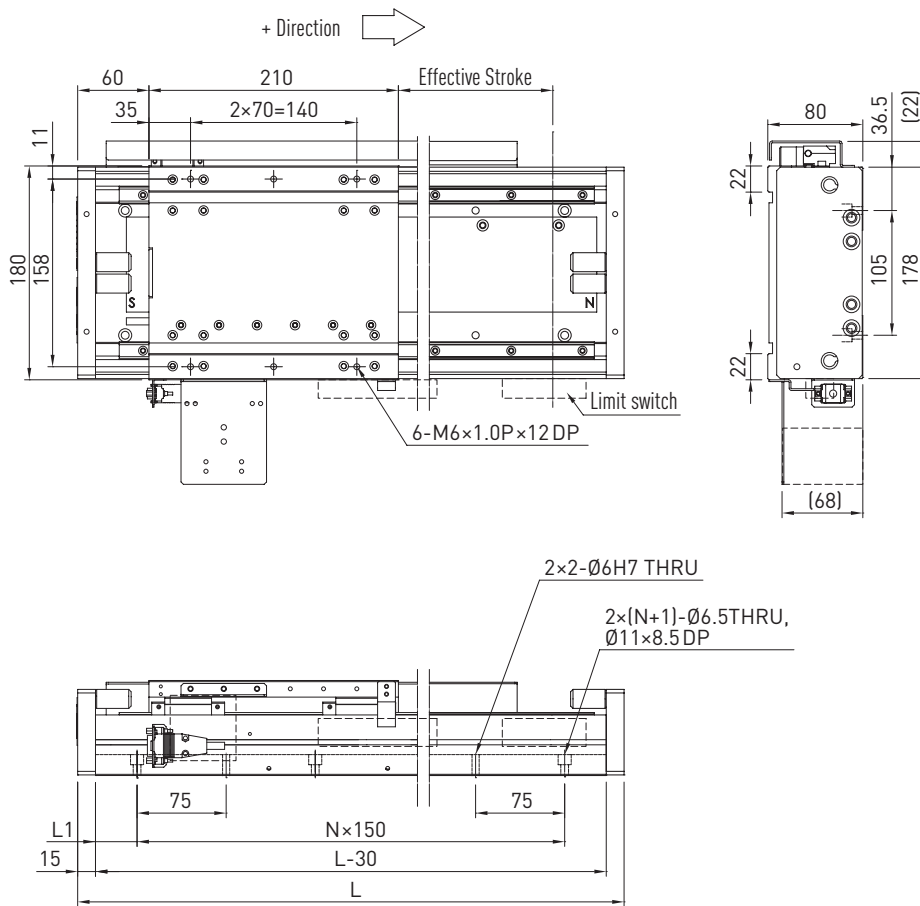

All values in mm

Table 5.4 Dimensions and weights of LMX1E-CB6 without cover

Stroke length [mm]	100	200	300	400	500	600	700	800	900	1,000	1,100	1,200
Total length L [mm]	430	530	630	730	830	930	1,030	1,130	1,230	1,330	1,430	1,530
L1 [mm]	50	25	75	50	25	75	50	25	75	50	25	75
N	1 ¹⁾	3	3	4	5	5	6	7	7	8	9	9
Weight [kg]	19	23	27	31	35	39	43	47	51	55	59	63

¹⁾ When stroke length = 100 mm the mounting hole distance increases from 150 to 300 mm

Linear Motor Systems

Linear motor axis LMX1E

Dimensions and weights of the LMX1E-CB7 linear motor axis without cover

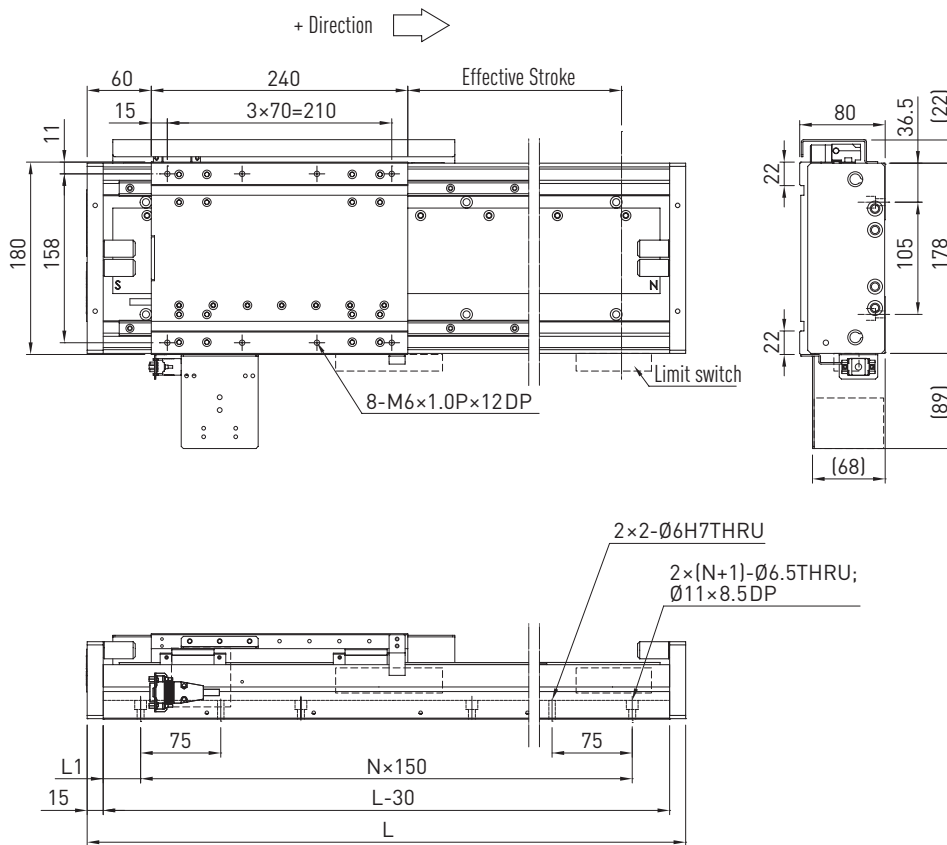

All values in mm

Table 5.5 Dimensions and weights of LMX1E-CB7 without cover

Stroke length [mm]	100	200	300	400	500	600	700	800	900	1,000	1,100	1,200
Total length L [mm]	460	560	660	760	860	960	1,060	1,160	1,260	1,360	1,460	1,560
L1 [mm]	65	40	90	65	40	90	65	40	90	65	40	90
N	1 ¹⁾	3	3	4	5	5	6	7	7	8	9	9
Weight [kg]	20	24	28	32	36	40	44	48	52	56	60	64

¹⁾ When stroke length = 100 mm the mounting hole distance increases from 150 to 300 mm

Dimensions and weights of the LMX1E-CB8 linear motor axis without cover

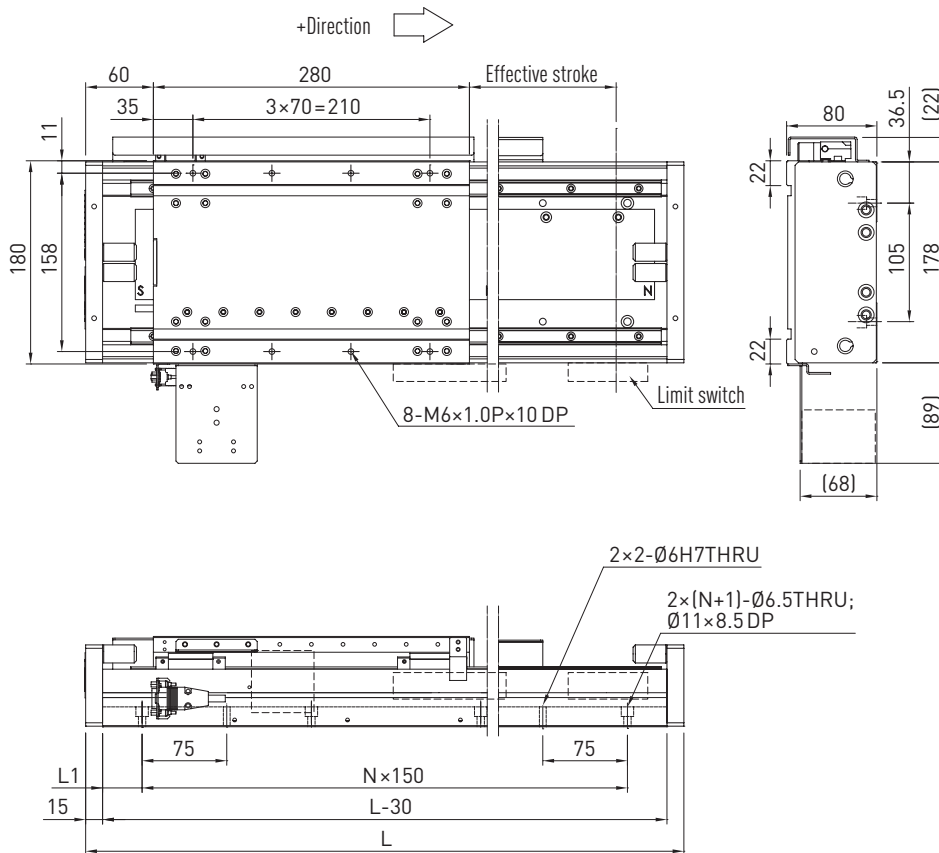

All values in mm

Table 5.6 Dimensions and weights of LMX1E-CB8 without cover

Stroke length [mm]	100	200	300	400	500	600	700	800	900	1,000	1,100	1,200
Total length L [mm]	500	600	700	800	900	1,000	1,100	1,200	1,300	1,400	1,500	1,600
L1 [mm]	85	60	35	85	60	35	85	60	35	85	60	35
N	1 ¹⁾	3	4	4	5	6	6	7	8	8	9	10
Weight [kg]	21	25	29	33	37	41	45	49	53	57	61	65

¹⁾ When stroke length = 100 mm the mounting hole distance increases from 150 to 300 mm

Linear Motor Systems

Linear motor axis LMX1E

5.4.2 LMX1E linear motor axes with cover

Dimensions and weights of the LMX1E-CB5 linear motor axis with cover

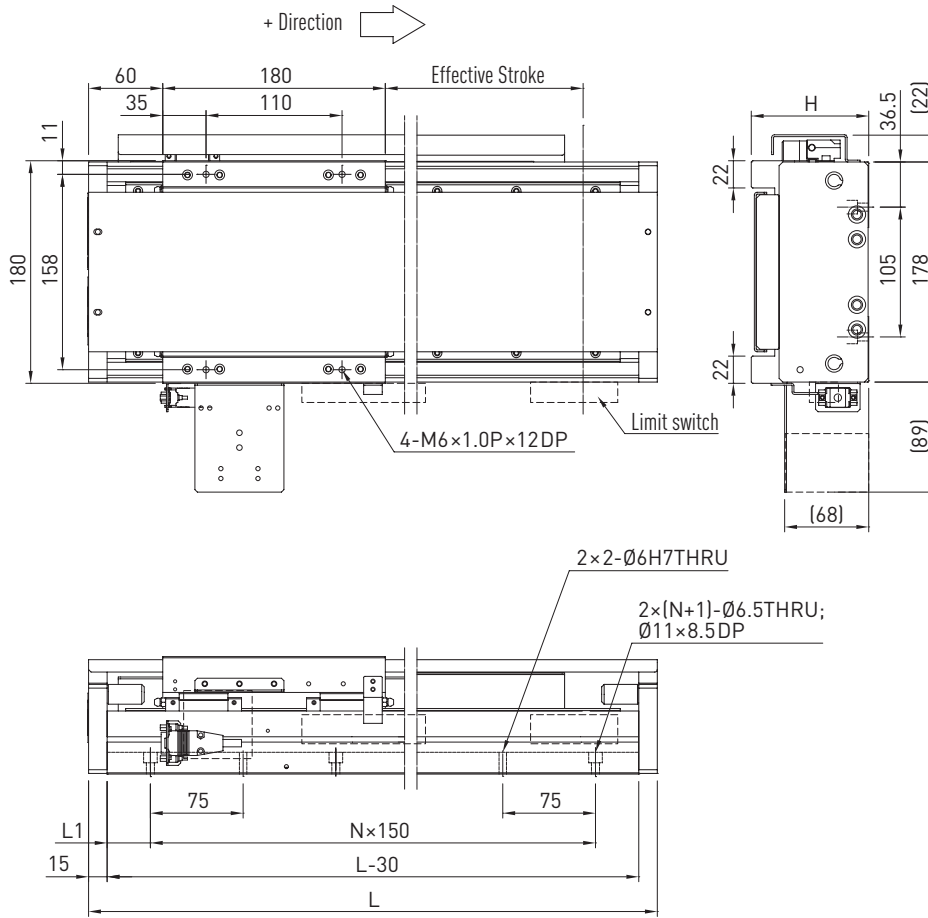

All values in mm

Table 5.7 Dimensions and weights of LMX1E-CB5 with cover

Stroke length [mm]	100	200	300	400	500	600	700	800	900	1,000	1,100	1,200
Total length L [mm]	400	500	600	700	800	900	1,000	1,100	1,200	1,300	1,400	1,500
L1 [mm]	35	85	60	35	85	60	35	85	60	35	85	60
N	1 ¹⁾	2	3	4	4	5	6	6	7	8	8	9
Weight [kg]	19	23	27	31	35	39	43	47	51	55	59	63
H [mm]	95	95	95	95	95	95	95	95	95	95	105	105

¹⁾ When stroke length = 100 mm the mounting hole distance increases from 150 to 300 mm

Dimensions and weights of the LMX1E-CB6 linear motor axis with cover

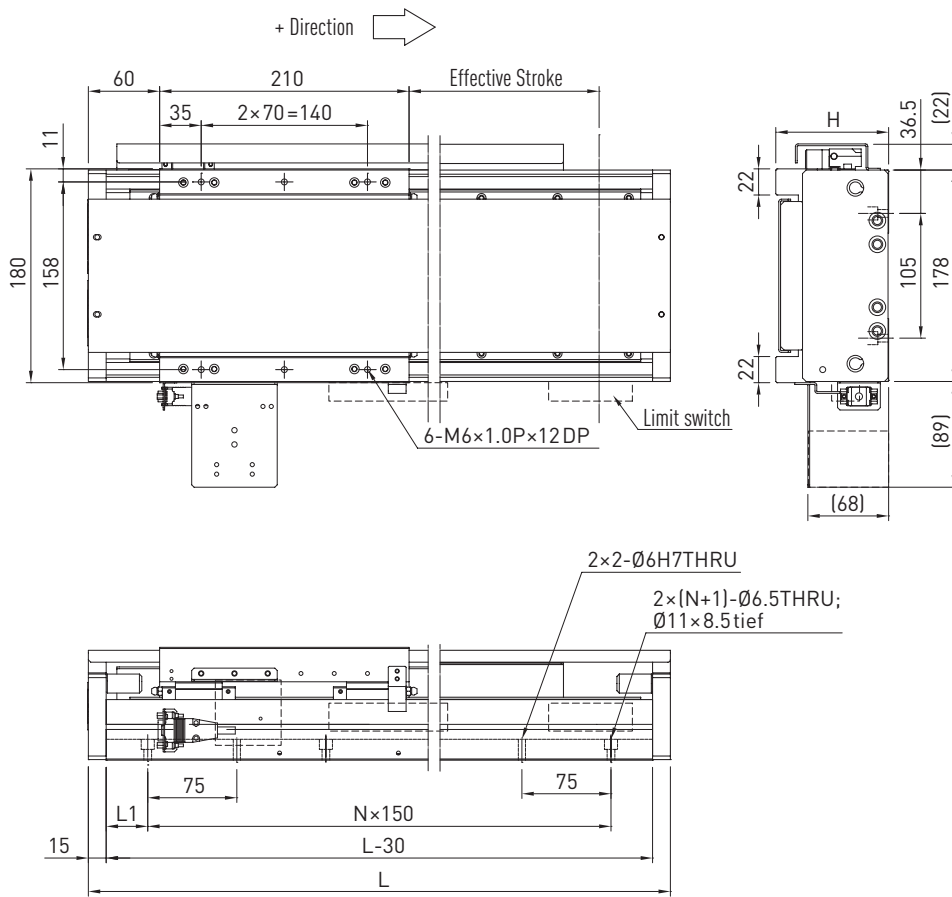

All values in mm

Table 5.8 Dimensions and weights of LMX1E-CB6 with cover

Stroke length [mm]	100	200	300	400	500	600	700	800	900	1,000	1,100	1,200
Total length L [mm]	430	530	630	730	830	930	1,030	1,130	1,230	1,330	1,430	1,530
L1 [mm]	50	25	75	50	25	75	50	25	75	50	25	75
N	1 ¹⁾	3	3	4	5	5	6	7	7	8	9	9
Weight [kg]	20	24	28	32	36	40	44	48	52	56	60	64
H [mm]	95	95	95	95	95	95	95	95	95	95	105	105

¹⁾ When stroke length = 100 mm the mounting hole distance increases from 150 to 300 mm

Linear Motor Systems

Linear motor axis LMX1E

Dimensions and weights of the LMX1E-CB7 linear motor axis with cover

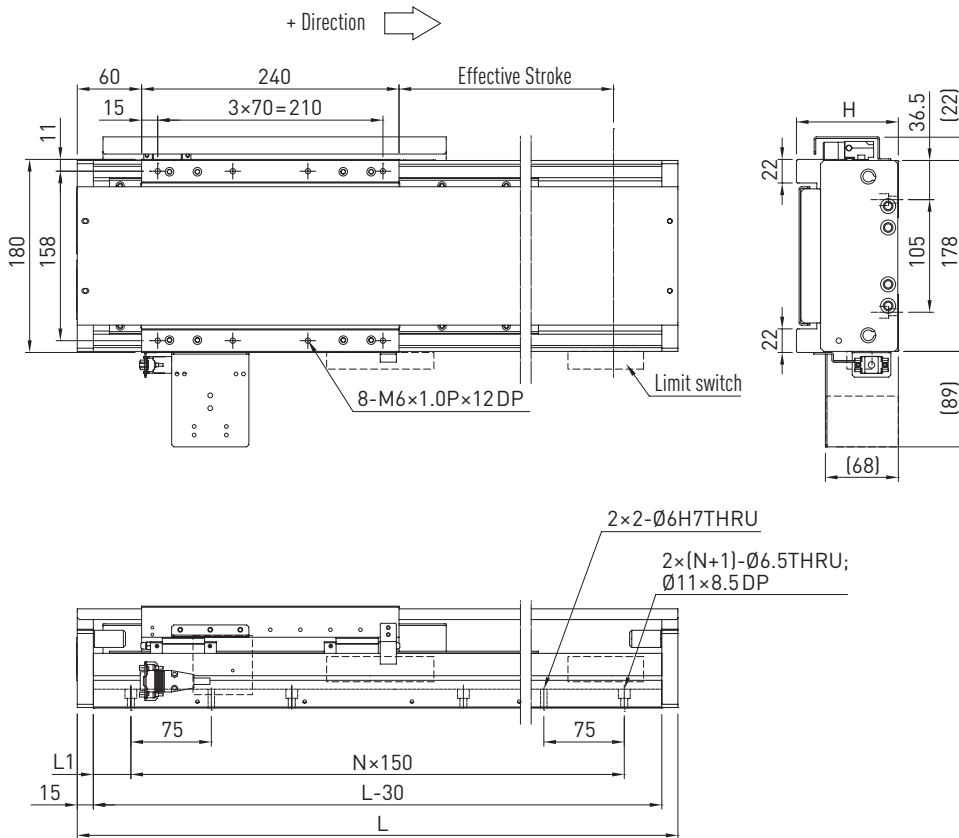

All values in mm

Table 5.9 Dimensions and weights of LMX1E-CB7 with cover

Stroke length [mm]	100	200	300	400	500	600	700	800	900	1,000	1,100	1,200
Total length L [mm]	460	560	660	760	860	960	1,060	1,160	1,260	1,360	1,460	1,560
L1 [mm]	65	40	90	65	40	90	65	40	90	65	40	90
N	1 ¹⁾	3	3	4	5	5	6	7	7	8	9	9
Weight [kg]	21	25	29	33	37	41	45	49	53	57	61	65
H [mm]	95	95	95	95	95	95	95	95	95	95	105	105

¹⁾ When stroke length = 100 mm the mounting hole distance increases from 150 to 300 mm

Dimensions and weights of the LMX1E-CB8 linear motor axis with cover

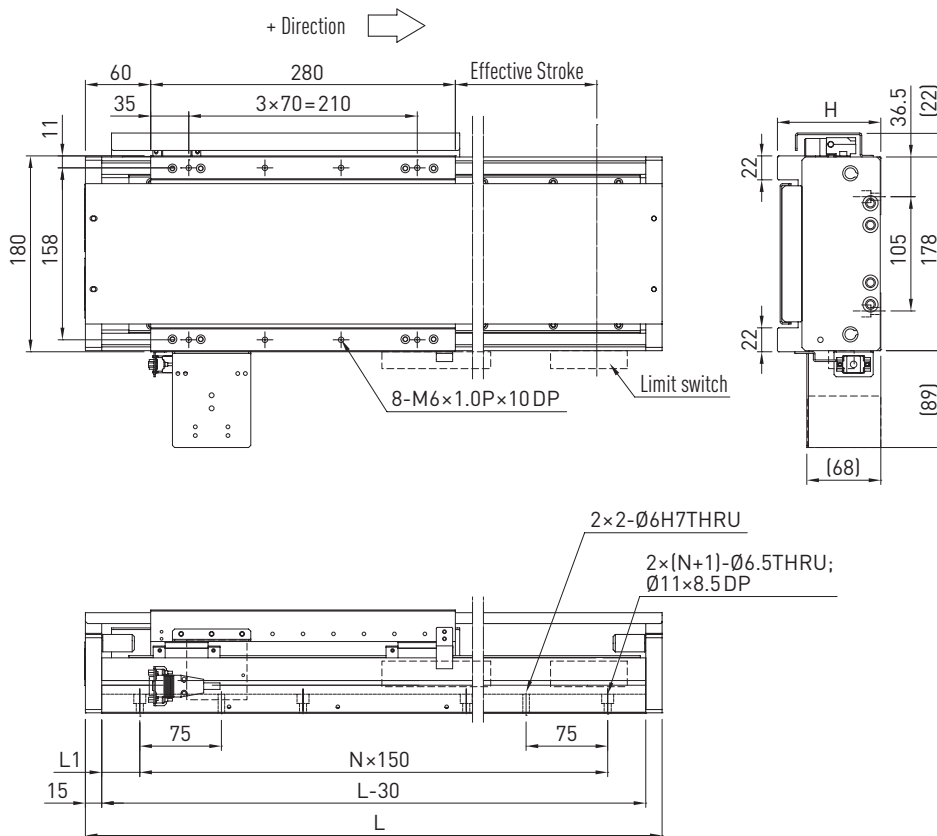

All values in mm

Table 5.10 Dimensions and weights of LMX1E-CB8 with cover

Stroke length [mm]	100	200	300	400	500	600	700	800	900	1,000	1,100	1,200
Total length L [mm]	500	600	700	800	900	1,000	1,100	1,200	1,300	1,400	1,500	1,600
L1 [mm]	85	60	35	85	60	35	85	60	35	85	60	35
N	1 ¹⁾	3	4	4	5	6	6	7	8	8	9	10
Weight [kg]	22	26	30	34	38	42	46	50	54	58	62	66
H [mm]	95	95	95	95	95	95	95	95	95	95	105	105

¹⁾ When stroke length = 100 mm the mounting hole distance increases from 150 to 300 mm

Linear Motor Systems

High-speed linear motor axis LMV

6. High-speed linear motor axis LMV

6.1 Properties of the LMV linear motor axes

The new generation of small- to medium-load LMV linear motor axes was developed specifically for “more compact, lighter, and highly dynamic” solutions. The considerably reduced moving masses and the new linear motors from the LMSA series gave rise to a highly dynamic positioning axis that can bring its advantages to bear for both horizontal and vertical applications. Unlike other linear motor axes, the HIWIN linear motor axis LMV is characterised by maximised mechanical stability in a compact, weight-optimised design.

The QE series linear guideways featuring tried-and-tested SynchMotion™ technology have been optimised for high synchronism, speed, and acceleration; minimum noise emissions; and very long relubrication intervals. The extremely compact and virtually wear-free weight compensation operates with a magnetic constant force spring or pneumatic cylinder for the best dynamic properties in vertical applications.



Advantages of the LMV vertical axis

- Highly dynamic positioning axis, for vertical and horizontal applications
- Repeatability 0.005 mm with absolute distance measuring system
- Compact, zero-play setup
- Minimised cycle times
- Maximised mechanical rigidity
- Protected against dust
- Maximum process reliability and service life thanks to wear-free drive

6.2 Order code for LMV linear motor axes

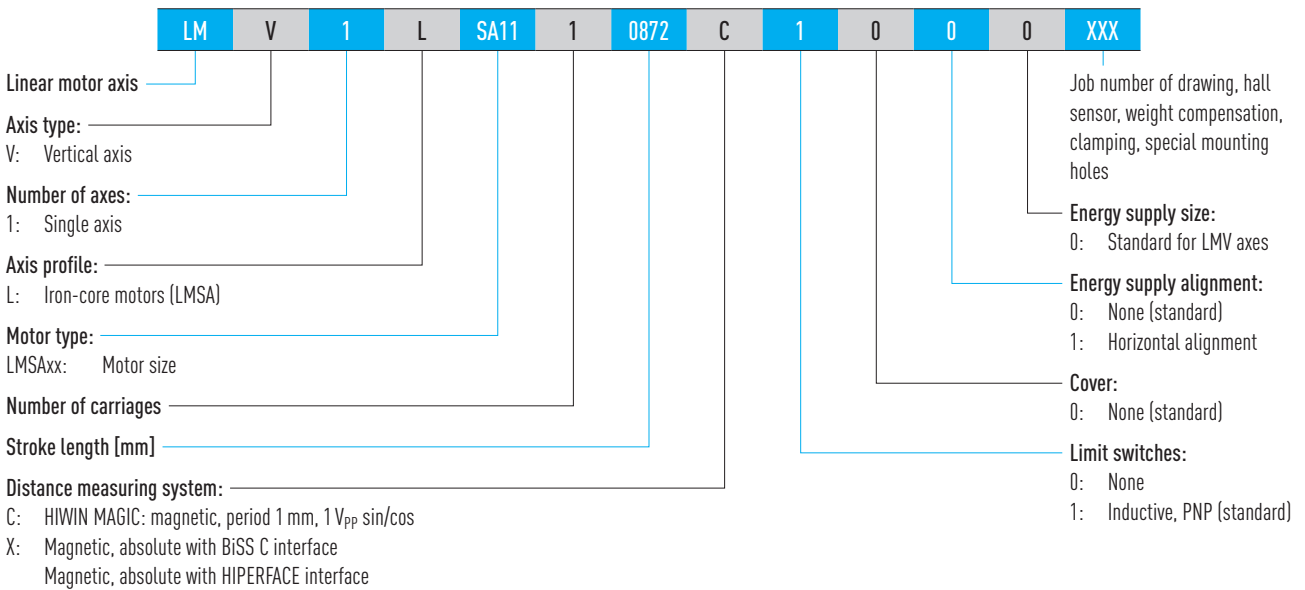

6.3 Linear motor axis LMV specifications

Stroke length [mm]	50	180	300
Max. acceleration [m/s ²]	50		
Max. velocity [m/s]	2.5		
Max. payload [kg]	3	30 ¹⁾	
Motor	LMSA11		
Continuous force [N]	103		
Peak force [N]	289		
Repeatability [mm]	0.005 ²⁾		
Profile rail	QE15		
Distance measuring system	Absolute magnetic BiSS C; absolute magnetic HIPERFACE; incremental magnetic		
Clamping (optional)	Yes		
Weight compensation (optional)	Constant force spring	Constant force spring, pneumatic cylinder	
Energy chain (optional)	Yes		

¹⁾ With pneumatic weight compensation

²⁾ With absolute distance measuring system

Dimensions of the linear motor axis LMV

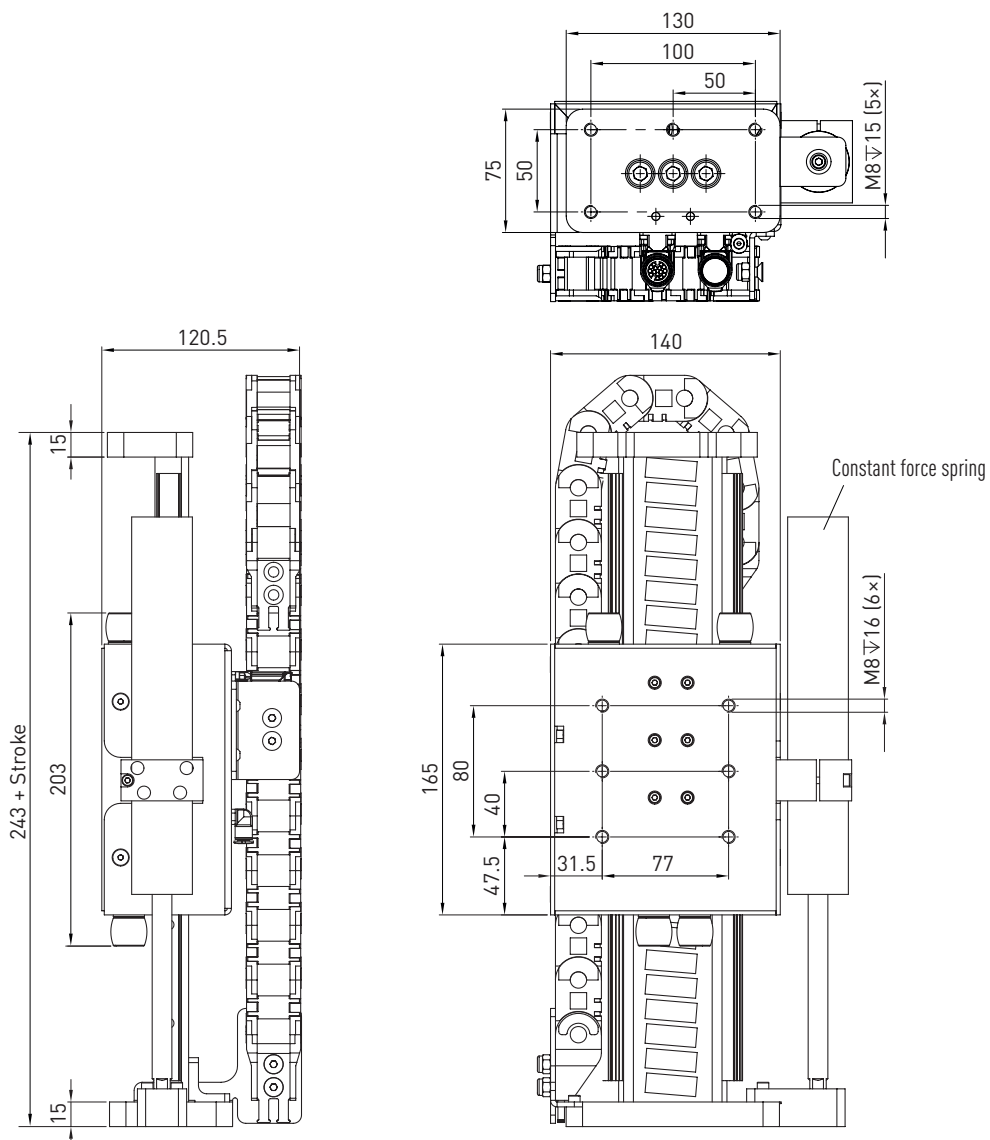

All values in mm

7.3.1 LMX2E-CB5-CB8 cross table without cover

Dimensions and weights of the LMX2E-CB5-CB8 cross table without cover

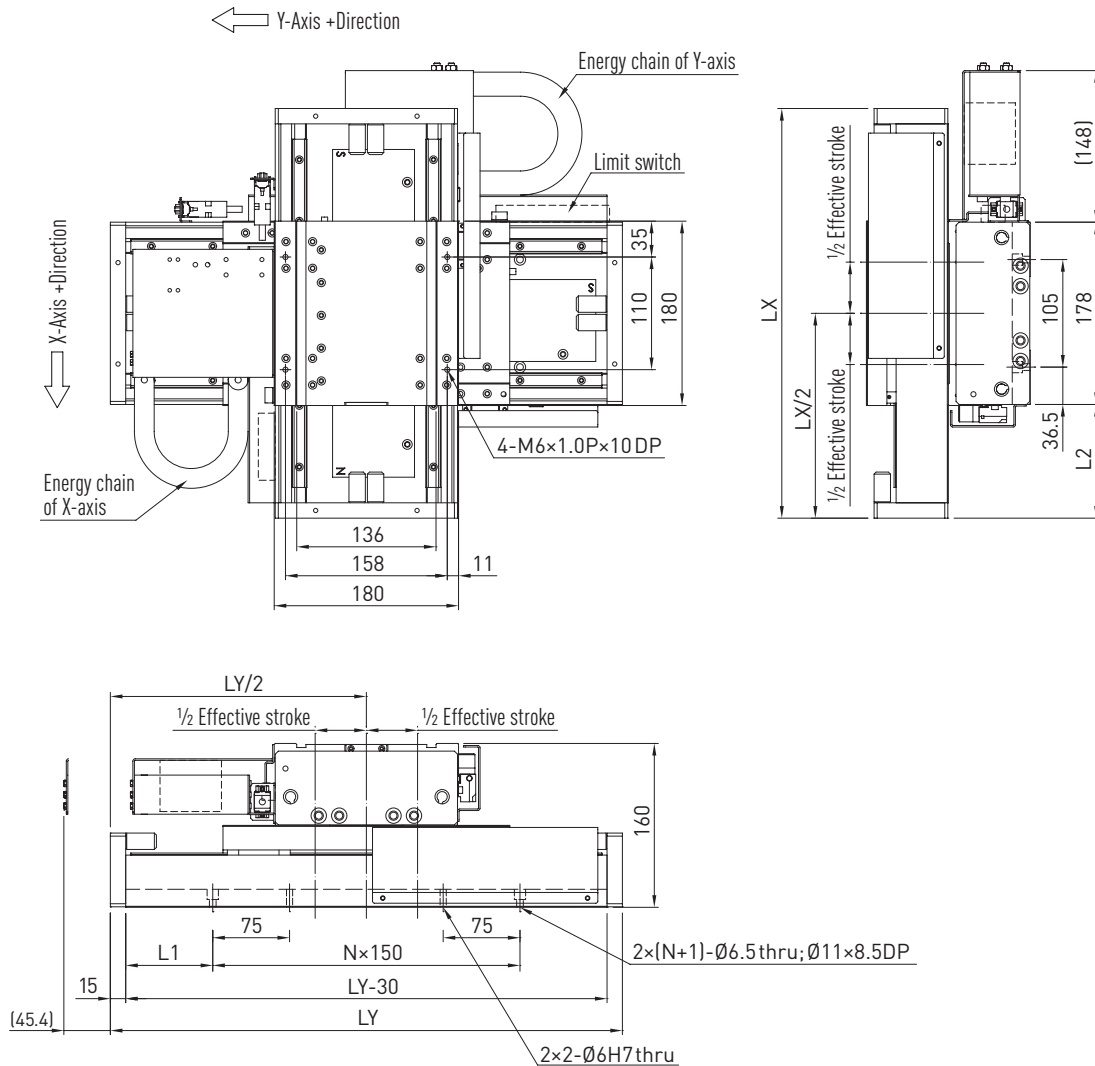

All values in mm

Table 7.2 Dimensions and weights of LMX2E-CB5-CB8 without cover

Stroke length [mm]		Total length [mm]		L1 [mm]	L2 [mm]	N	Weight of carriage axis X [kg]	Weight of carriage axis Y [kg]	Total weight cross table [kg]
Axis X	Axis Y	LX	LY						
100	100	400	500	85	111	1 ¹⁾	2.5	20	44
100	200	400	600	60	111	3	2.5	20	46
200	200	500	600	60	161	3	2.5	22	48
100	300	400	700	35	111	4	2.5	20	48
200	300	500	700	35	161	4	2.5	22	50
300	300	600	700	35	211	4	2.5	24	52
100	400	400	800	85	111	4	2.5	20	50
200	400	500	800	85	161	4	2.5	22	52
300	400	600	800	85	211	4	2.5	24	54

¹⁾ When stroke length = 100 mm the mounting hole distance increases from 150 to 300 mm

Linear Motor Systems

Cross table LMX2E

7.3.2 LMX2E-CB5-CB8 cross table with cover

Dimensions and weights of the LMX2E-CB5-CB8 cross table with cover

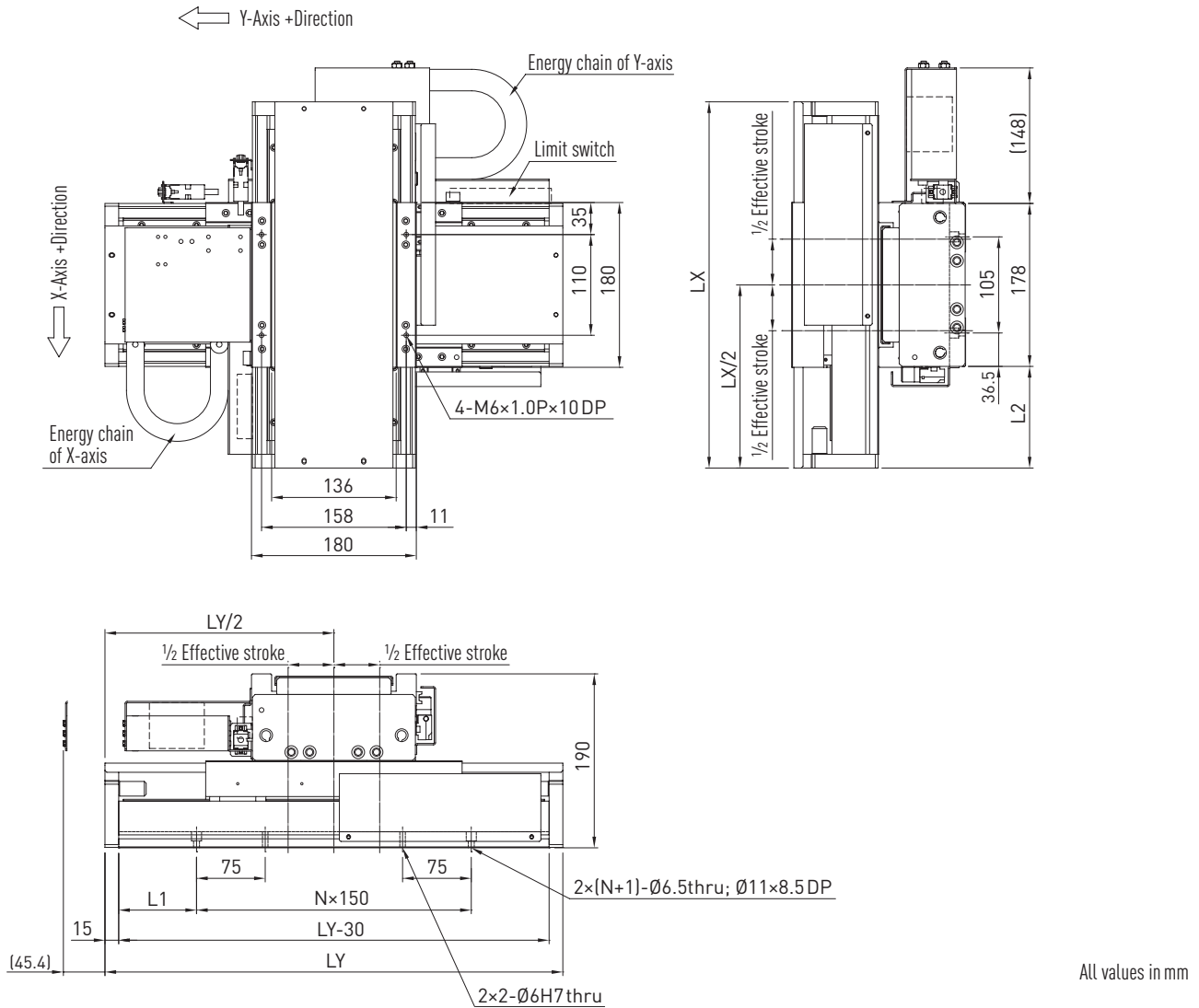

Table 7.3 Dimensions and weights of LMX2E-CB5-CB8 with cover

Stroke length [mm]		Total length [mm]		L1 [mm]	L2 [mm]	N	Weight of carriage axis X [kg]	Weight of carriage axis Y [kg]	Total weight cross table [kg]
Axis X	Axis Y	LX	LY						
100	100	400	500	85	111	1 ¹⁾	2.5	20	44
100	200	400	600	60	111	3	2.5	20	46
200	200	500	600	60	161	3	2.5	22	48
100	300	400	700	35	111	4	2.5	20	48
200	300	500	700	35	161	4	2.5	22	50
300	300	600	700	35	211	4	2.5	24	52
100	400	400	800	85	111	4	2.5	20	50
200	400	500	800	85	161	4	2.5	22	52
300	400	600	800	85	211	4	2.5	24	54

¹⁾ When stroke length = 100 mm the mounting hole distance increases from 150 to 300 mm

8. Gantry system LMG2A-C

8.1 Properties of the LMG2A-C gantry systems

The standardized gantry systems of the LMG2A series are systems with one-sided step bearings. The LMG2A-C type has coreless linear motors.

- Equipped with coreless linear motors
- Slight inertia and fast acceleration
- No cogging
- Stiff aluminium bridge

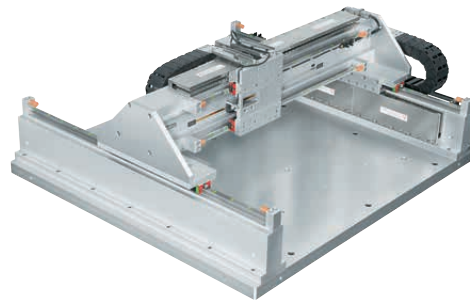

8.2 Order code for LMG2A-C gantry systems

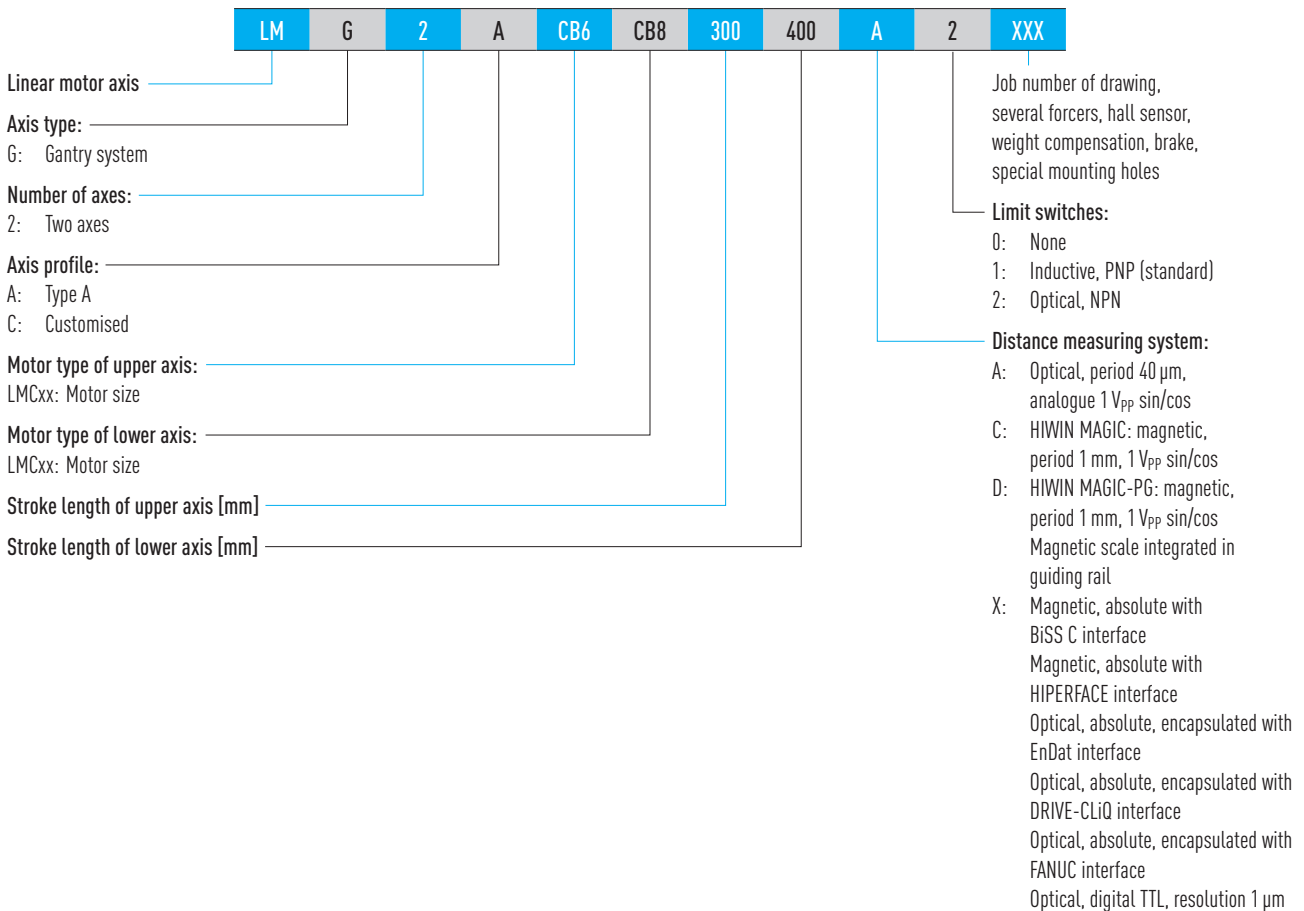

8.3 Gantry system LMG2A-C specifications

Name (article number) xxxx = stroke length [mm]	Orthogonality [arc-sec]	Repeatability [mm]	V _{max} [m/s]	a _{max} [m/s ²]	Motor type	F _c [N]	F _p [N]	Weight of carriage [kg]
LMG2A-CB6 CC8-xxxx-xxxx-A1	± 10	± 0.002/0.004	5	100	Upper axis: LMCB6	109	436	3.0
					Lower axis: LMCC8	145	580	Weight upper axis + 3.5

F_c = Continuous power, 100 % operating time (ED), at 100 °C winding temperature

F_p = Peak force (1 s)

Electrical parameters for linear motors: see catalogue "Linear Motors and Distance Measuring Systems"

Linear Motor Systems

Gantry system LMG2A-C

Dimensions and weights of the LMG2A-CB6 CC8 gantry system

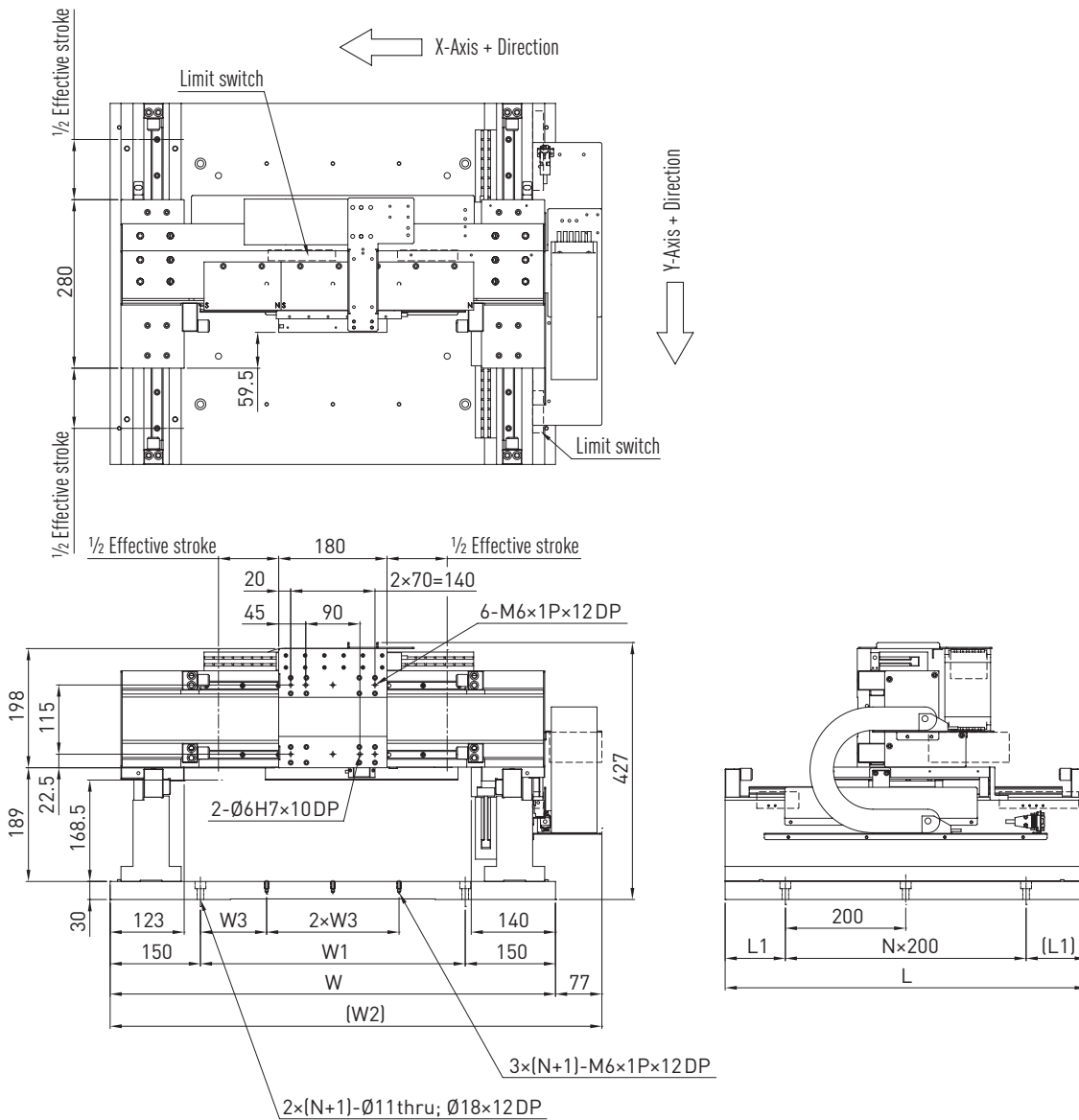

All values in mm

Table 8.2 Dimensions and weights of LMG2A-CB6 CC8 (axis X top)

Stroke length [mm]	W [mm]	W1 [mm]	W2 [mm]	W3 [mm]	Weight of carriage [kg]	Total weight axis X [kg]
200	740	440	817	110	5	25
300	840	540	917	135	5	29
400	940	640	1,017	160	5	33
500	1,040	740	1,117	185	5	37
600	1,140	840	1,217	210	5	41

Table 8.3 Dimensions and weights of LMG2A-CB6 CC8 (axis X below)

Stroke length [mm]	N	L [mm]	L1 [mm]	Weight of carriage [kg]
200	2	600	100	Total weight axis X + 6
300	3	700	50	Total weight axis X + 6
400	3	800	100	Total weight axis X + 6
500	4	900	50	Total weight axis X + 6
600	4	1,000	100	Total weight axis X + 6

9. Customized positioning systems

The standardized positioning stages shown in this catalogue are designed to handle many different kinds of positioning tasks. For positioning tasks that cannot be solved using standard stages, application engineers are available to work out an optimized solution.

A few customized solutions are shown on the next four pages.

9.1 Examples

Economic installation and inspection

XY gantry systems make many applications extremely economical. Setup of the gantry from standard components.

- Standard axis of the LMX1L series
- Repeatability $\pm 2 \mu\text{m}$
- Supplied with machine bed



Micro shapes and macro shapes

Milling and microstructures with cutting tools and lasers are application areas in which gantry systems can deliver a number of benefits. They are also an excellent buy for your money.

- Coreless LMC motors
- Repeatability $\pm 2 \mu\text{m}$
- Tried and tested technology with high output

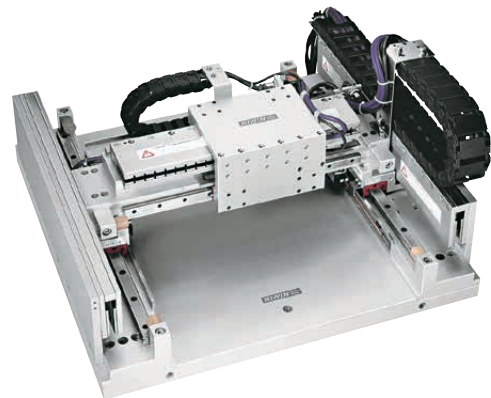

Wafer quality control at the highest level

High precision X-Y Stages with air-cushions are the prerequisites for surface monitoring, which even find the smallest errors, for example, in wafer production for the electronics and chip industries.

- Flatness $\pm 2 \mu\text{m}$
- Repeatability $\pm 0.5 \mu\text{m}$
- Accuracy $\pm 2 \mu\text{m}$
- Resolution 5 nm

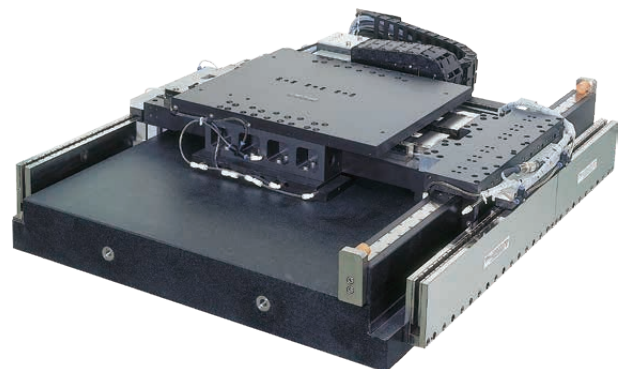

Linear Motor Systems

Customized positioning systems

Microsystem technology and wafer processing

Absolute precision and suitability for clean room conditions are the prerequisites for every drive in microsystem technology and wafer processing. Linear motor X-Y Stages are ideal for these tasks.

- Stroke 200 × 200 mm, optional 300 × 300 mm
- Flatness ± 4 µm across the complete stroke
- Repeatability ± 1 µm across both axes
- Accuracy ± 4 µm across both axes
- Clean room suitability class 100, optional class 10
- Optionally suitable for vacuums up to 10⁻³ mbar

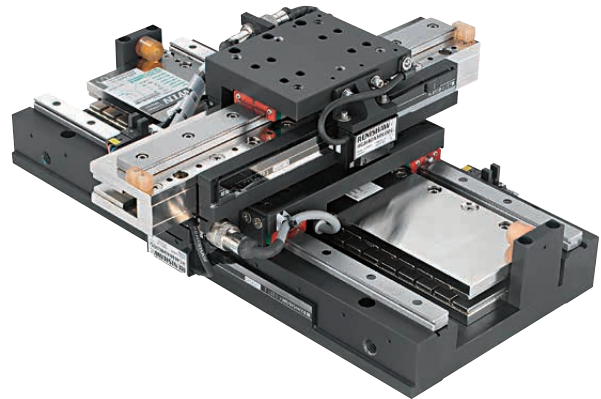

Overview for laser scanners

High degree of synchronization and extended operating lives are a must for optical inspection systems such as laser scanners. Linear motors with air bearings fulfil these requirements.

- No friction thanks to air bearings
- No cogging thanks to coreless linear motors
- Stroke length up to 1,500 mm

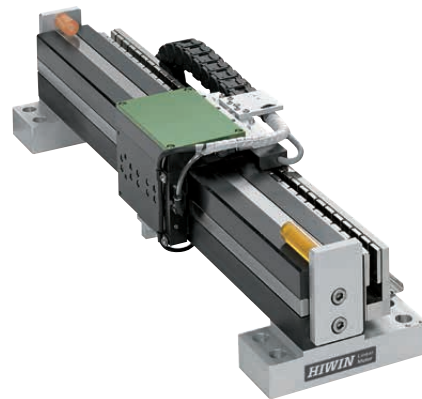

Photovoltaic-panel assembly

High dynamic positioning of silicium cells for 24 hours each day.

- Linear motors also in vertical axes enable a long durability
- Vertical axes with adjustable mass compensation and clamping element for emergency-stop

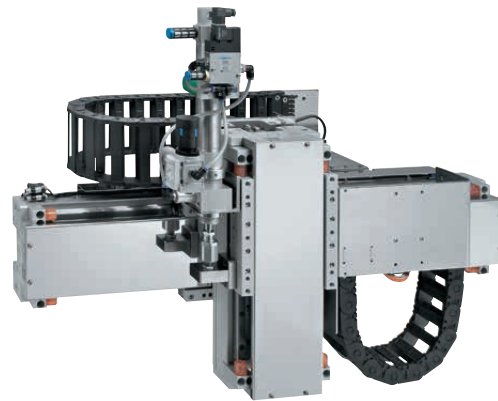

X-ray-inspection of printed circuit boards

Delivery of the whole linear-motor-system consisting of Linear motor axis, drives, cables for an inline inspection machine.

- System with coreless LMC components
- Stroke 550 × 550 mm
- Repeatability ± 1 µm
- High dynamism in spite of 100 kg mass to move

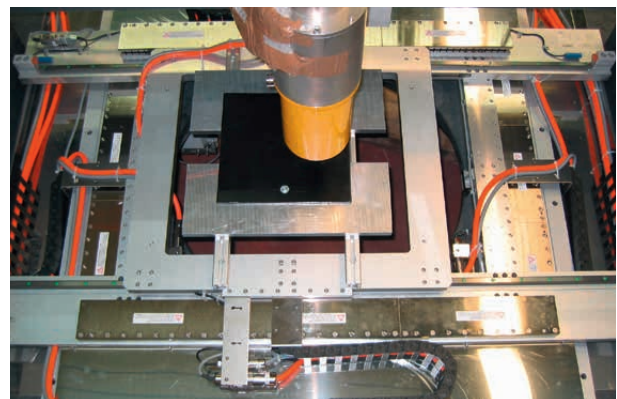

Automatic assembly

Dynamic Assembly of circuit boards in fully automated assembly lines.

- Gantry system with LMS components and KK stage (axis Z)
- Stroke $650 \times 660 \times 135$ mm. Options include longer travel distances along the lower axis
- Acceleration 20 m/s^2
- Flatness $\pm 20 \mu\text{m}$
- Rectangularity 0.01°
- Interferometrical survey of the axis
- Delivery ready assembled in the base frame



Moveable Saw

Linear motor axis enables the cutting during the transport of bars.

- Customised LM system with LMS47D
- Cycle time approx. 1.3 s (mass: 55 kg, stroke length: 1.5 m)
- Speed 3 m/s
- Acceleration 22 m/s^2



Film transport

Film transport Compact and flat linear motor axis with high power density integrated in the production line.

- Two parallel LMC axes
- Stroke length 300 mm
- All components assembled on a customised base frame 600×500 mm

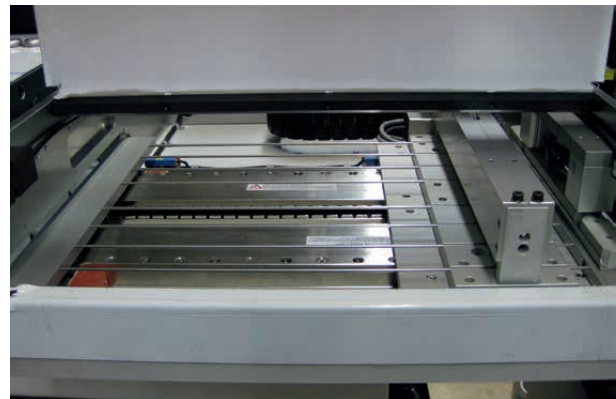

Laser trimming with maximum precision

Optimal results make a high demand on evenness and rectangularity on a large stroke. The metal particles of the laser machining necessitate the bellow cover.

- Cross table with bellow cover
- Stroke 700×750 mm
- Repeatability $\pm 2 \mu\text{m}$
- Flatness $\pm 0.01/300$ mm
- Rectangularity ± 5 arc-sec

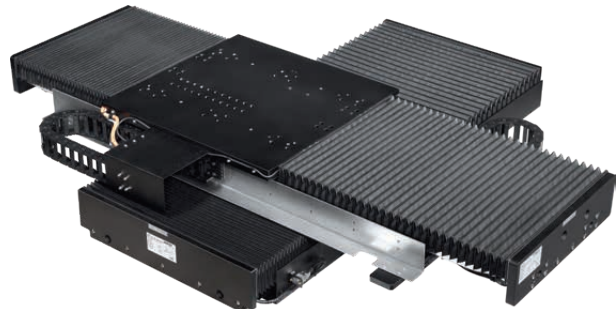

Linear Motor Systems

Customized positioning systems

Dispenser

Highest requirements on the flatness.

- Stroke of cross table: $150 \times 250 \times 60$ mm
- High rigidity of the lower axis due to the steel frame
- Upper axis stiffened by aluminium profile
- Creation of a calibration chart to compensate the deviation of the flatness
- Flatness $\pm 10/300$ mm
- Repeatability $5 \mu\text{m}$

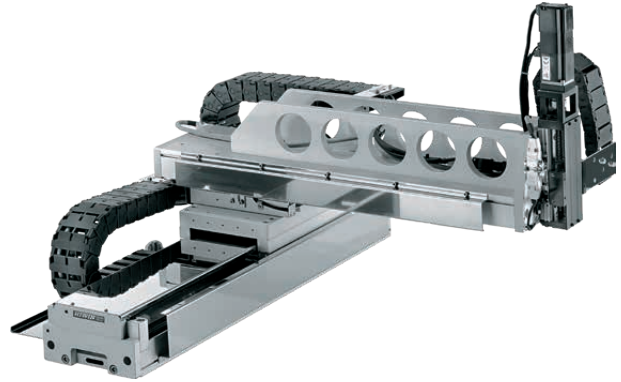

Laser scripting

High accuracy due the use of glass scales.

- Customised LMC linear motor system
- Stroke 400×110 mm
- Lower axis positions the workpiece. Upper axis operates the laser
- Repeatability $\pm 1 \mu\text{m}$
- Rectangularity $8 \mu\text{m}$
- Flatness $\pm 5 \mu\text{m}$

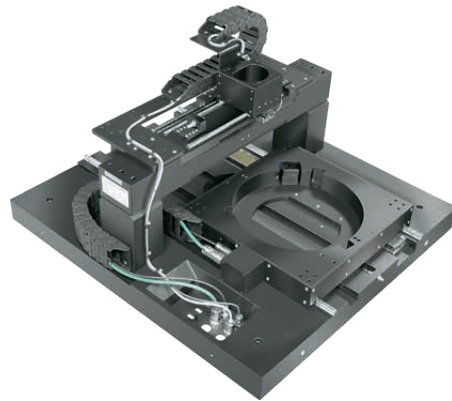

Laser exposure

Excellent results enabled due to the very smooth motion of the coreless linear motor axis.

- 4 forcers on each axis
- High degree of synchronization due to the use of special linear guideways
- Optimised adaptation of the axis profile to the existing machine frame



We live motion.

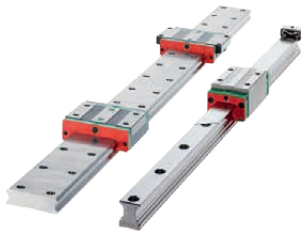

Linear Guideways



Ballscrews



Linear Axes

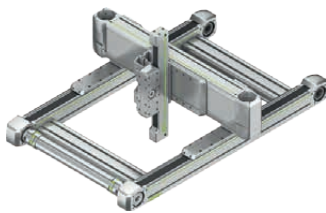

Linear Axis Systems



Torque Motors



Robots

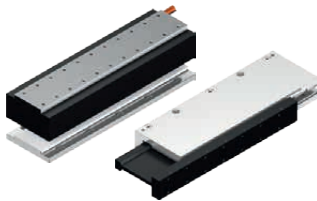

Linear Motors



Rotary Tables



Drives & Servo Motors

Germany

HIWIN GmbH
Brücklesbünd 1
D-77654 Offenburg
Phone +49 (0) 7 81 9 32 78 - 0
Fax +49 (0) 7 81 9 32 78 - 90
info@hiwin.de
www.hiwin.de

Taiwan

Headquarters
HIWIN Technologies Corp.
No. 7, Jingke Road
Taichung Precision Machinery Park
Taichung 40852, Taiwan
Phone +886-4-2359-4510
Fax +886-4-2359-4420
business@hiwin.tw
www.hiwin.tw

Taiwan

Headquarters
HIWIN Mikrosystem Corp.
No. 6, Jingke Central Road
Taichung Precision Machinery Park
Taichung 40852, Taiwan
Phone +886-4-2355-0110
Fax +886-4-2355-0123
business@hiwinmikro.tw
www.hiwinmikro.tw

France

HIWIN GmbH
4, Impasse Joffre
F-67202 Wolfisheim
Phone +33 (0) 3 88 28 84 80
contact@hiwin.fr
www.hiwin.fr

Italy

HIWIN Srl
Via Pitagora 4
I-20861 Brugherio (MB)
Phone +39 039 287 61 68
Fax +39 039 287 43 73
info@hiwin.it
www.hiwin.it

Poland

HIWIN GmbH
ul. Puławska 405a
PL-02-801 Warszawa
Phone +48 22 544 07 07
Fax +48 22 544 07 08
info@hiwin.pl
www.hiwin.pl

Switzerland

HIWIN Schweiz GmbH
Eichwiesstrasse 20
CH-8645 Jona
Phone +41 (0) 55 225 00 25
Fax +41 (0) 55 225 00 20
info@hiwin.ch
www.hiwin.ch

Slovakia

HIWIN s.r.o., o.z.z.o.
Mládežnícka 2101
SK-01701 Považská Bystrica
Phone +421 424 43 47 77
Fax +421 424 26 23 06
info@hiwin.sk
www.hiwin.sk

Czech Republic

HIWIN s.r.o.
Medkova 888/11
CZ-62700 Brno
Phone +42 05 48 528 238
Fax +42 05 48 220 223
info@hiwin.cz
www.hiwin.cz

Netherlands

HIWIN GmbH
info@hiwin.nl
www.hiwin.nl

Austria

HIWIN GmbH
info@hiwin.at
www.hiwin.at

Romania

HIWIN GmbH
info@hiwin.ro
www.hiwin.ro

Slovenia

HIWIN GmbH
info@hiwin.si
www.hiwin.si

Hungary

HIWIN GmbH
info@hiwin.hu
www.hiwin.hu

Denmark

HIWIN GmbH
info@hiwin.dk
www.hiwin.dk

China

HIWIN Corp.
www.hiwin.cn

Japan

HIWIN Corp.
info@hiwin.co.jp
www.hiwin.co.jp

USA

HIWIN Corp.
info@hiwin.com
www.hiwin.com

Korea

HIWIN Corp.
www.hiwin.kr

Singapore

HIWIN Corp.
www.hiwin.sg