

## X-Y LM SHIELD Thermic-welded Cover with Laminations

- **X-Y LM Shield:** composed of 4 thermic-welded bellows and screened with stainless steel laminations.
- It is the solution that is a low-cost, robust and lightweight combination for separating the working area from the motor compartment.
- **X-Y LM Shield** reaches speeds of up to 120 m/min and acceleration up to 1g.

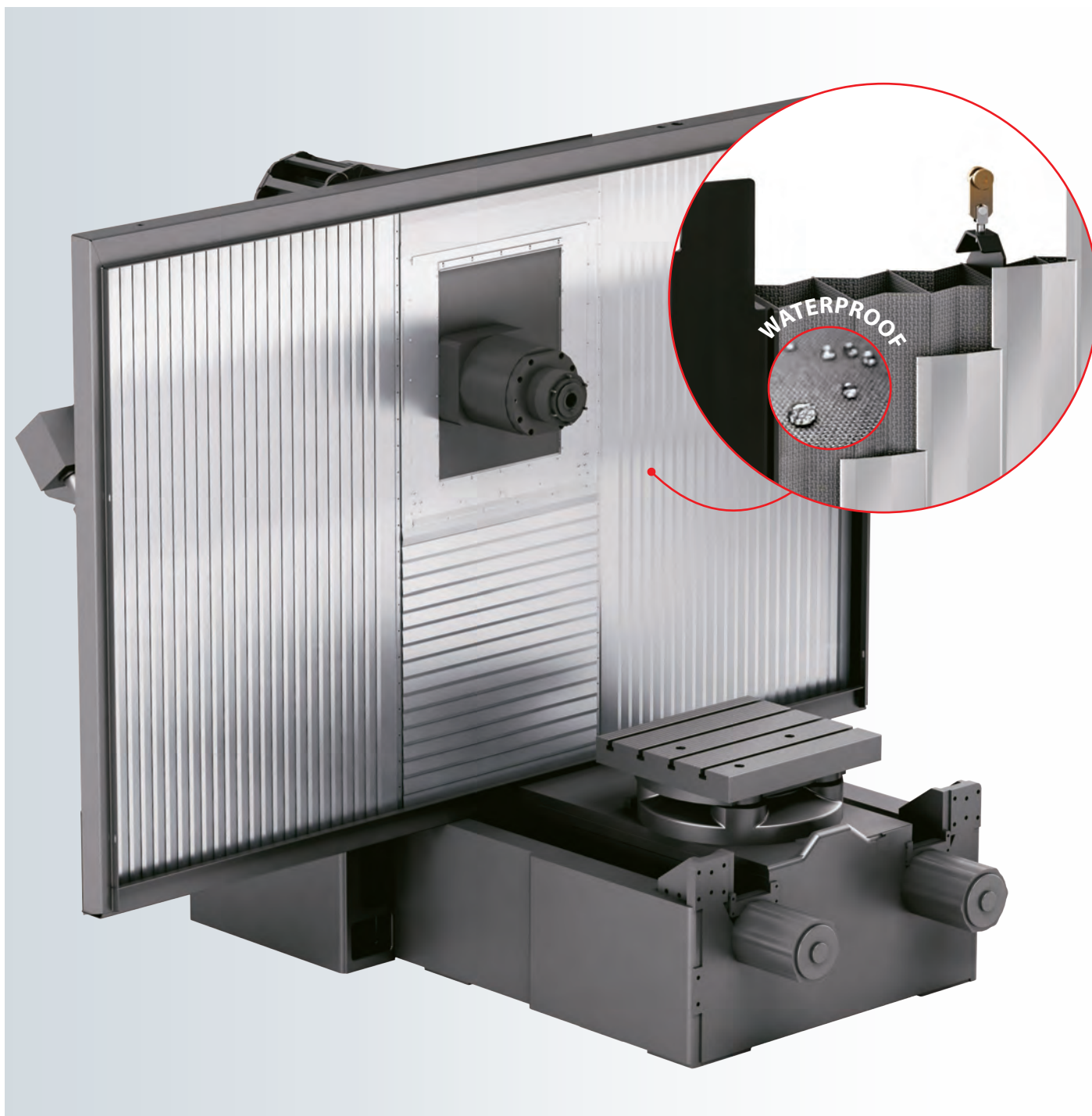

Reproduction of this page is strictly prohibited.



## X-Y LM SHIELD Thermic-welded Cover with Laminations

- **X-Y LM Shield:** This system guarantees double protection as the laminations shield the bellow from hot and sharp shavings while the bellow enfolds and defends the guides from liquids getting under the laminations.
- Widely used on horizontal and vertical, small to large working centres.



Reproduction of this page is strictly prohibited.

### Application example



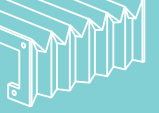

**X-Y LM SHIELD** Thermic-welded Cover with Laminations



**Packing for the shipment**



*Reproduction of this page is strictly prohibited.*

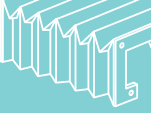

## GIANT SHIELD A gigantic protective wall

**NEW**

- **GIANT SHIELD**, a gigantic protective wall characterised by its dimensions beyond normal standards, which is suited for huge machine tools where large parts are machined.

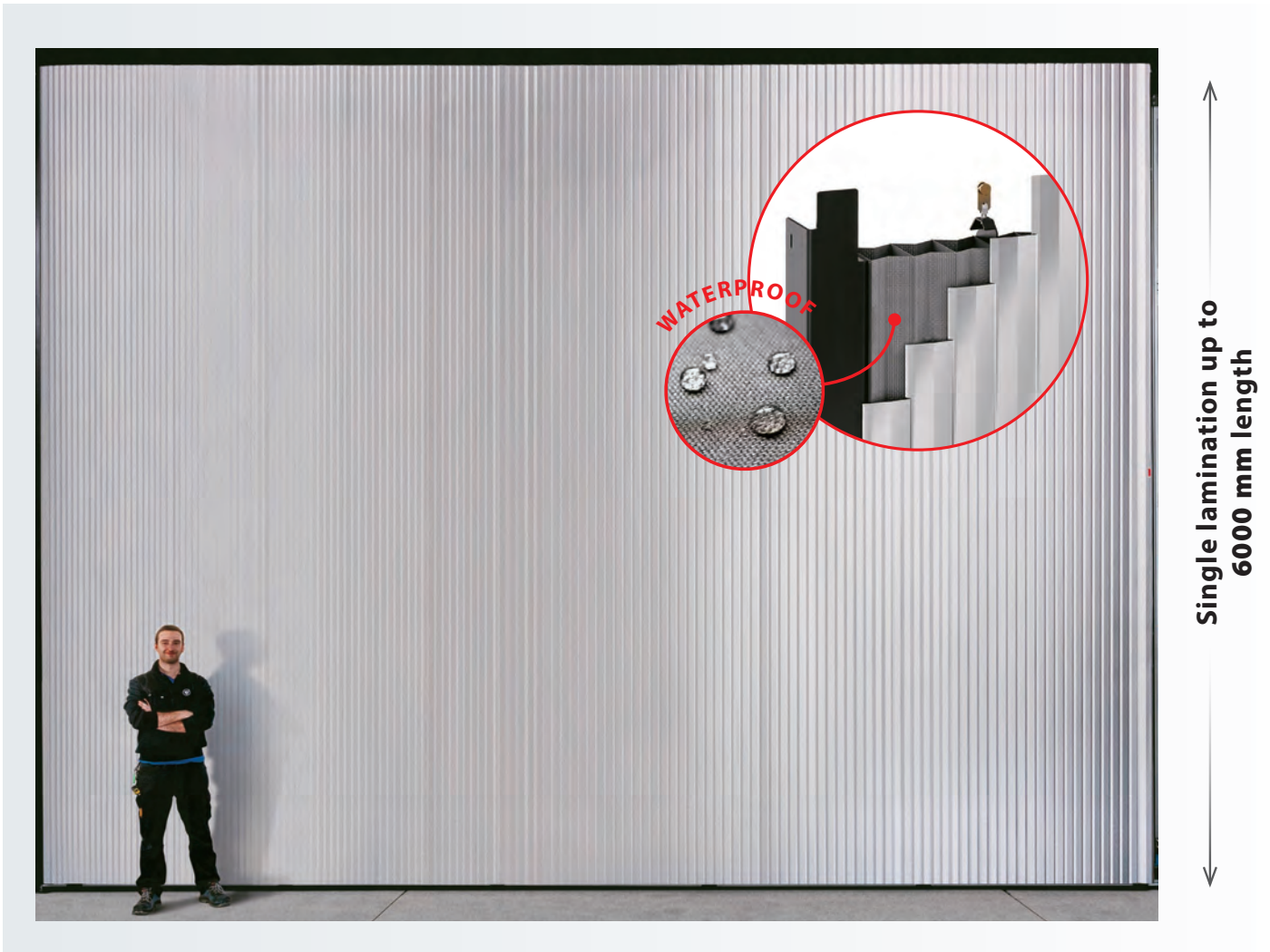

- The 0,3 mm thick laminations represent the rigid part of the cover, a protective barrier against incandescent chips escaping during the machining of work pieces. **GIANT SHIELD** can be built up to a height of 6000 mm. The special properties of its laminations allow for a dynamic movement with elasticity, rigidity and ease. The bellow behind the laminations is thermally welded along its entire height and made of special fabric, all of which prevents the coolant from permeating. The steel laminations on their own would not have been able to guarantee such impermeability. **GIANT SHIELD** follows each transverse movement of the machine head.

