

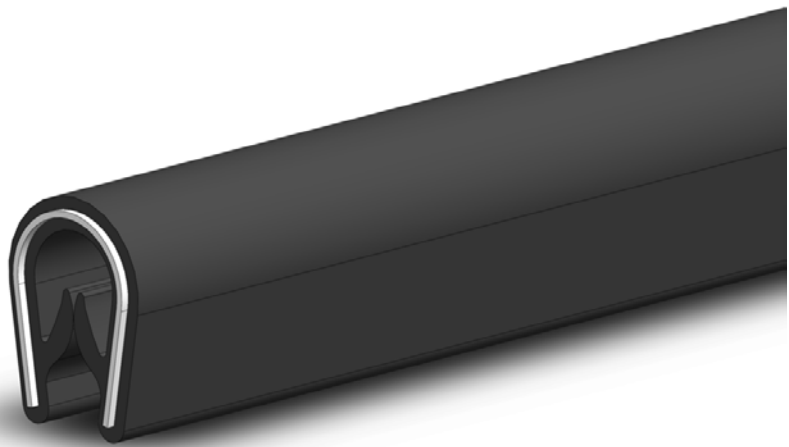

Edge protection profiles



DESIGNED
FOR ENGINEERING



DESIGNED
FOR ENGINEERING

Edge protection profiles and edge protection seal profiles

General notes

Introduction

Edge protection profiles are installed on the front edge of metal sheets and plates. They protect surfaces from damage by sharp edges. Meanwhile, edge protection seal profiles feature a seal profile in order to provide additional sealing for doors, covers and hatches.

Uses and applications

With the use of edge protection when handling equipment and machine parts made of sheet metal profiles, the risk of cuts or abrasions is reduced to a minimum. In the process, in these applications the profiles provide a visual "decorative effect." Other application possibilities include cable and tube laying, where openings and edges of divider plates need to be bypassed. This provides reliable protection from flaking or worn-down cables and tubes.

In general, using edge protection profiles can reduce the need for further treatment such as burring and chamfering of cut or laser-cut metal sheets.

Edge protection seal profiles provide the same benefits as edge protection profiles. However they are recommended for use in cases where doors, covers and hatches require additional sealing in order to prevent the emission of dust, warm air or noise; for example, or in order to prevent water spray from entering.

Structure

Edge protection profiles consist of an extruded clamping profile which forms the base of the structure and is used on the edge of sheet metal in order to affix the edge protection profile.

In order to increase the clamping force, the clamping profile is strengthened through a reinforcement, preventing the profile from detaching itself after assembly.

The clamp insert is available as a steel clamping band or as a steel wire polyester clamping band. Steel clamping bands have a higher clamping effect, while steel wire clamping bands allow a smaller assembly radius, also enabling a more even alignment of the edges.

The seal profile is affixed to the top or the side of the clamping profile and is significantly "softer". It can be made from the basic material of the clamping profile but it can also be made from particular materials for specific applications. In order to attain optimum sealing, the seal profile needs to be prestressed and/or formed to enable it to adapt precisely to the countersurface.

The sealing lips in the interior of the clamping profile ensure the sealing of the edge protection seal profile with the edge of the sheet.

Assembly

Side cutters and scissors that are suitable for cutting the metal clamping insert can be used to align the profiles. Any end parts of the clamp insert that protrude from the cutting area should be removed in order to prevent injuries. The profile ends and cants can be subsequently sealed and/or glued as required.

The mounting of the profiles to the edges is secured via the clamp insert. Glue or other adhesives are not usually required.

Profiles can generally be assembled by applying pressure by hand. If necessary, the profile can additionally be secured by lightly applying a soft-face hammer.

Edge protection profiles

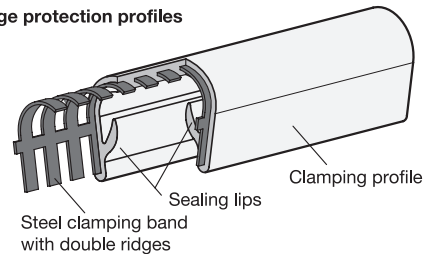

Edge protection seal profiles

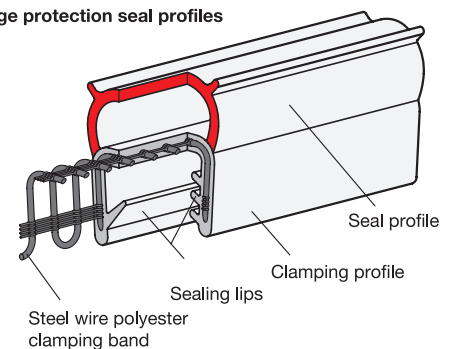

Edge protection profiles and edge protection seal profiles

Technical information

Minimum placement radii

In order to ensure a consistent seal for the profile and to prevent the profile from detaching, placement should not be set below the minimum radii. This also makes the profile assembly easier.

The radii are listed on the corresponding standard sheets and should be used as a guideline. Depending on the direction of application, a distinction is made between cut or curved radii, in other words, interior or exterior seal profiles.

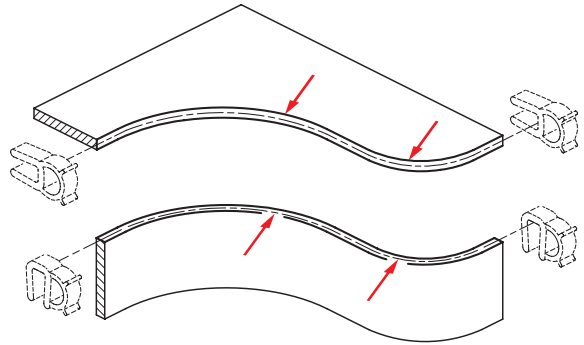

Shaping

Ideally, edge protection seal profiles should maintain a deformation x of approximately 30 - 50% of the maximum value in order to ensure a reliable sealing.

Deformation of over 50% can impair seal tightness and reduce the resilience of the sealing material due to plastic deformation.

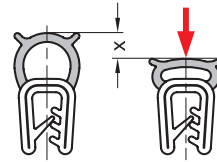

Basic materials, characteristics

Profiles can be made from various basic materials depending on the application. The table to the right summarizes the general characteristics to facilitate the choice.

Due to the multitude of chemicals, solvents etc. exact specifications are not possible, as basic materials that are fundamentally unstable can be durable in combination with specific materials and vice versa. Concentration, temperature and exposure time also play a crucial role. The customer is advised to test resistance when combining respective materials in contact with one another.

* + resistant, o conditionally resistant, – non-resistant

Characteristics	PVC	NBR	EPDM
Operational temperature min.	-40 °C	- 30 °C	- 40 °C
Operational temperature max.	+70 °C	+100 °C	+100 °C
Abrasion resistance / Wear resistance	+	+	+
Deformation resistance	o	+	+
Resistant to: *			
• UV light / weather exposure	+	-	+
• Chemicals	+	-	+
• Oil, greases	o	+	-
• Fuels	o	+	-
• Acids	+	o	+
• Alkalines	o	+	+
• Solvents	o	o	o
• Alcohol	o	o	+

UL certification (Seal profiles as EPDM)

UL (Underwriters Laboratories) is an independent global company operating in safety science, similar to TÜV in Germany. Their testing is required as a priority in the US-American market.

Edge protection seal profiles GN 2180 (see page 4) made of EPDM have a "UL-recognized component" mark. This states that the profiles can be used as components in finished products which are also intended for UL-certified use.

For customers and companies, the need for these types of certification is becoming increasingly important, as it guarantees high quality, reliable processing, and long durability, as well as reliable product safety.



Edge protection seal profiles

Material NBR / EPDM (UL-certified)

SPECIFICATION

Types

- Type **A**: Upper seal profile
- Type **D**: Side seal profile

Clamping profile / Sealing profile

Ethylene propylene diene rubber **EPDM**

- black
- Clamping profile hardness 65 ±5 Shore A
- Sealing profile hardness 25 ±5 Shore A
- temperature resistant -40 °C to 100 °C

Acrylonitrile butadiene rubber **NBR**

(only for sizes $h_1 = 20.5$ and 13)

- black
- Clamping profile hardness 60 ±5 Shore A
- Sealing profile hardness 25 ±5 Shore A
- temperature resistant -30 °C to 100 °C

Clamp insert

Steel wire polyester clamping band



INFORMATION

Edge protection seal profiles GN 2180 can be used to seal doors, covers and hatches. The profiles are pressed by hand onto the front of metal sheets and plates. The embedded clamp insert prevents detachment. Glue or other adhesives are not required.

When assembled, the profile should deform slightly according to w_2 . This ensures an optimal seal. Adherence to the guideline placement radii ($r_1... r_4$) is recommended in order to ensure a tight profile seal and to make assembly easier.

The NBR profiles are recommended for use in cases where contact with fuels, oils or coolants can occur.

EPDM profiles are certified according to UL 50 and UL 94-HB and are therefore approved for the US-American and the Canadian market.

TECHNICAL INFORMATION

- Technical information for edge protection profiles (see page 3)
- Elastomer characteristics (see page A32)

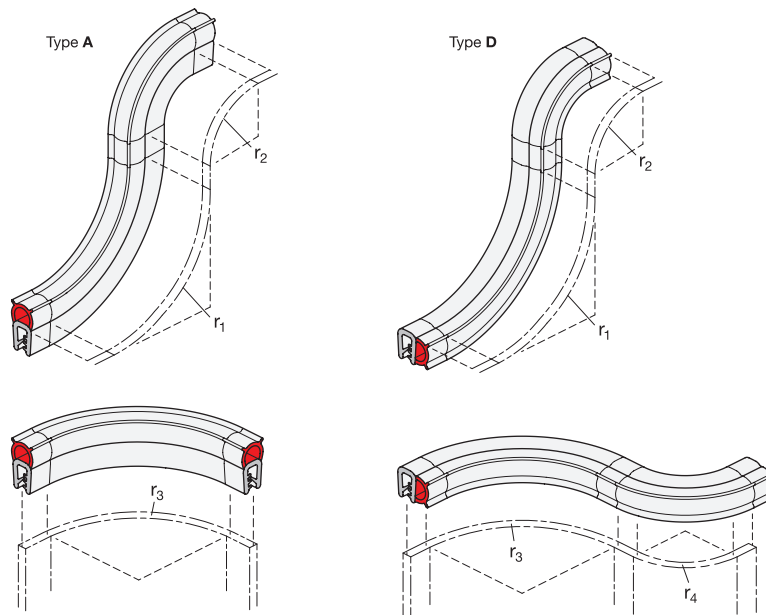

Type A

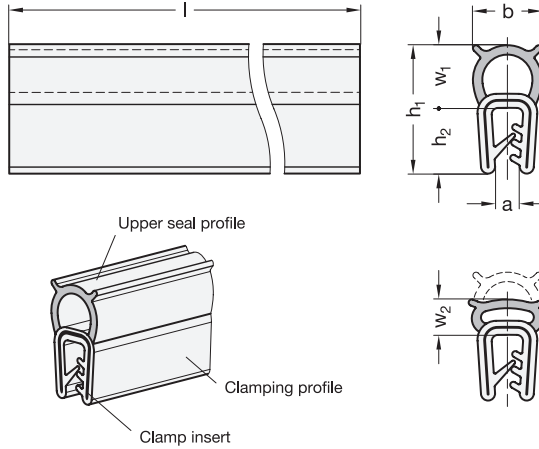

Type D

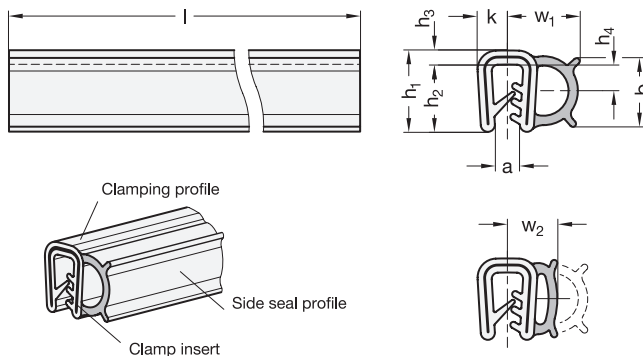

GN 2180

Description	h1	Cutting length l in m	a	b	h2	h3	h4	k	r1	r2	r3	r4	w1	w2 up to 50% permissible deformation	⚖
GN 2180-EPDM-15,5-A-20	15.5	20	0.8 - 2.5	8.5	9	-	-	-	80	50	20	-	6.5	5	2800
GN 2180-EPDM-15,5-A-50	15.5	50	0.8 - 2.5	8.5	9	-	-	-	80	50	20	-	6.5	5	5600
GN 2180-EPDM-20,5-A-20	20.5	20	1 - 3.5	11	10.5	-	-	-	90	50	30	-	10	7	2800
GN 2180-EPDM-20,5-A-50	20.5	50	1 - 3.5	11	10.5	-	-	-	90	50	30	-	10	7	7130
GN 2180-EPDM-11,5-D-20	11.5	20	0.8 - 2.5	8.75	9	2.5	3.75	4	30	40	80	40	8.5	6.75	2500
GN 2180-EPDM-11,5-D-50	11.5	50	0.8 - 2.5	8.75	9	2.5	3.75	4	30	40	80	40	8.5	6.75	5600
GN 2180-EPDM-13-D-20	13	20	1 - 3.5	11	10.75	2.25	4.5	4.75	40	50	100	80	11.25	8.75	2800
GN 2180-EPDM-13-D-50	13	50	1 - 3.5	11	10.75	2.25	4.5	4.75	40	50	100	80	11.25	8.75	7500
GN 2180-NBR-20,5-A-20	20.5	20	1 - 3.5	11	10.5	-	-	-	90	50	30	-	10	7	3000
GN 2180-NBR-20,5-A-50	20.5	50	1 - 3.5	11	10.5	-	-	-	90	50	30	-	10	7	7500
GN 2180-NBR-13-D-20	13	20	1 - 3.5	11	10.75	2.25	4.5	4.75	40	50	100	80	11.25	8.75	3000
GN 2180-NBR-13-D-50	13	50	1 - 3.5	11	10.75	2.25	4.5	4.75	40	50	100	80	11.25	8.75	7000

Edge protection seal profile corners

Material NBR / EPDM (UL-certified)

SPECIFICATION

Types

- Type **A**: Upper seal profile
- Type **D**: Side seal profile

Clamping profile / Sealing profile

Ethylene propylene diene rubber **EPDM**

- black
- Clamping profile hardness 65 ±5 Shore A
- Sealing profile hardness 25 ±5 Shore A
- temperature resistant -40 °C to 100 °C

Acrylonitrile butadiene rubber **NBR**

- black
- Clamping profile hardness 60 ±5 Shore A
- Sealing profile hardness 25 ±5 Shore A
- temperature resistant -30 °C to 100 °C

Clamp insert

Steel wire polyester clamping band

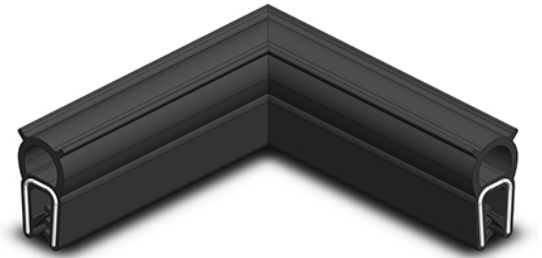

INFORMATION

With edge protection seal profiles corners GN 2181, right-angle sealing paths can be quickly and easily implemented without a minimum laying radius or manual "free-cutting" of the profile. The corner joint is sealed and firmly attached thanks to vulcanization.

The leg length l can be shortened or extended with the corresponding section of GN 2180 (see page 4). Installed "compressed" with an excess dimension of about 1% of the total length, the joints are tightly fitting and do not require adhesive.

During operation, the profile must experience deformation to dimension w_2 in order to ensure an optimal sealing effect. The profiles made of NBR are intended for uses in contact with oils, fuels or lubricants. The EPDM versions are made of UL 50 and UL 94-HB certified edge protector sealing profiles.

TECHNICAL INFORMATION

- Technical information for edge protection profiles (see page 3)
- Elastomer characteristics (see page A32)

ON REQUEST

- Edge protection seal profile segments, vulcanized, e.g. in U or Z shape
- Edge protection seal profile frame, vulcanized, closed, e.g. in round or square shape

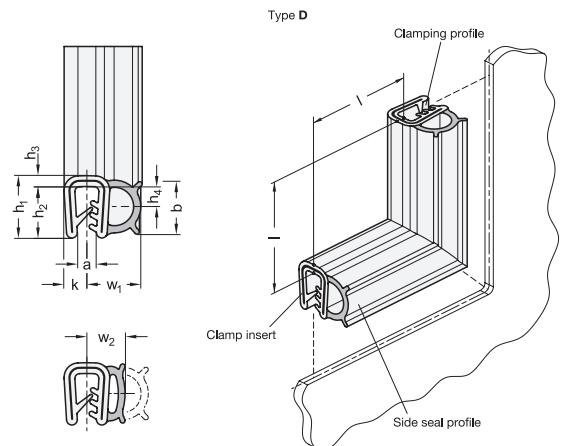
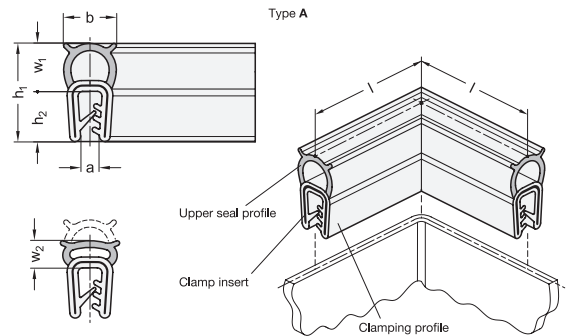

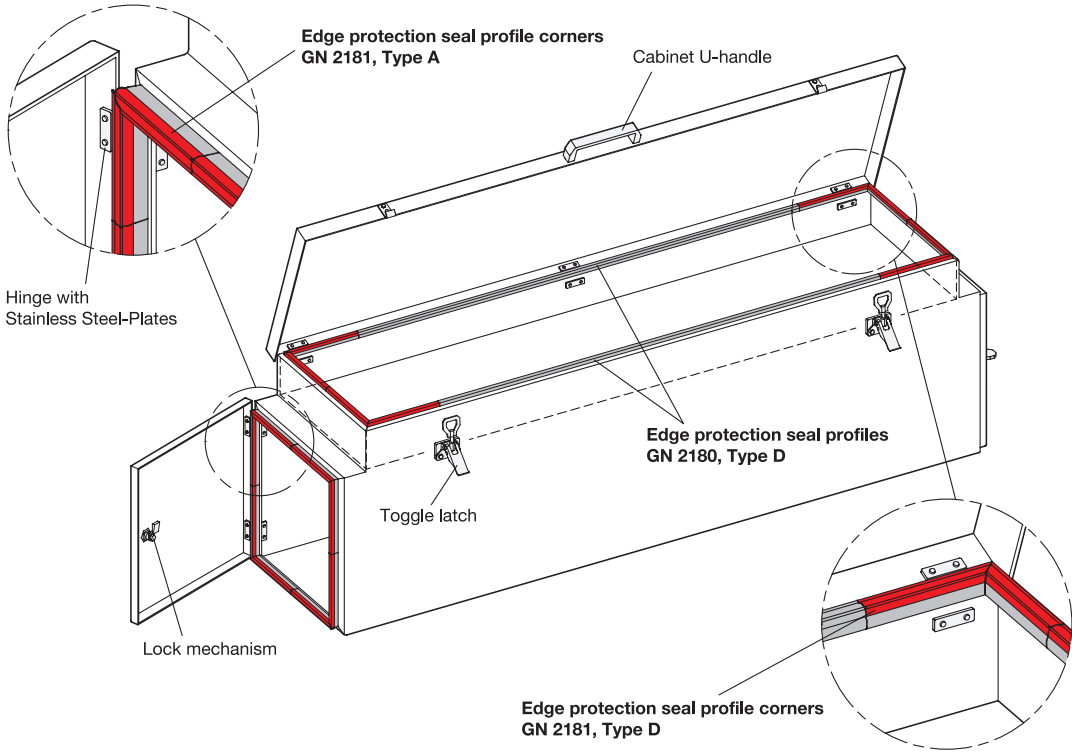

GN 2181

Description	h1	length l	a	b	h2	h3	h4	k	w1	w2 up to 50% permissible deformation	⚖
GN 2181-EPDM-13-D-160	13	160 ±2	1 - 3.5	11	10.75	2.25	4.5	4.75	11.25	8.75	45
GN 2181-EPDM-13-D-250	13	250 ±2.5	1 - 3.5	11	10.75	2.25	4.5	4.75	11.25	8.75	70
GN 2181-EPDM-13-D-400	13	400 ±3.2	1 - 3.5	11	10.75	2.25	4.5	4.75	11.25	8.75	112
GN 2181-EPDM-13-D-630	13	630 ±4	1 - 3.5	11	10.75	2.25	4.5	4.75	11.25	8.75	180
GN 2181-EPDM-20.5-A-160	20.5	160 ±2	1 - 3.5	11	10.5	-	-	-	10	7	44
GN 2181-EPDM-20.5-A-250	20.5	250 ±2.5	1 - 3.5	11	10.5	-	-	-	10	7	70
GN 2181-EPDM-20.5-A-400	20.5	400 ±3.2	1 - 3.5	11	10.5	-	-	-	10	7	110
GN 2181-EPDM-20.5-A-630	20.5	630 ±4	1 - 3.5	11	10.5	-	-	-	10	7	171
GN 2181-NBR-13-D-160	13	160 ±2	1 - 3.5	11	10.75	2.25	4.5	4.75	11.25	8.75	45
GN 2181-NBR-13-D-250	13	250 ±2.5	1 - 3.5	11	10.75	2.25	4.5	4.75	11.25	8.75	70
GN 2181-NBR-13-D-400	13	400 ±3.2	1 - 3.5	11	10.75	2.25	4.5	4.75	11.25	8.75	110
GN 2181-NBR-13-D-630	13	630 ±4	1 - 3.5	11	10.75	2.25	4.5	4.75	11.25	8.75	180
GN 2181-NBR-20.5-A-160	20.5	160 ±2	1 - 3.5	11	10.5	-	-	-	10	7	45
GN 2181-NBR-20.5-A-250	20.5	250 ±2.5	1 - 3.5	11	10.5	-	-	-	10	7	70
GN 2181-NBR-20.5-A-400	20.5	400 ±3.2	1 - 3.5	11	10.5	-	-	-	10	7	110
GN 2181-NBR-20.5-A-630	20.5	630 ±4	1 - 3.5	11	10.5	-	-	-	10	7	175

Edge protection seal profiles

Material combination PVC / EPDM

SPECIFICATION

Types

- Type **A**: Upper seal profile
- Type **D**: Side seal profile

Clamping profile

Polyvinyl Chloride (PVC)

Hardness 70±5 Shore A

Sealing profile

Ethylene propylene diene rubber (EPDM)

Hardness 25±5 Shore A

Clamp insert

Steel clamping band

- black
- temperature resistant -40 °C to 90 °C
- weather exposure

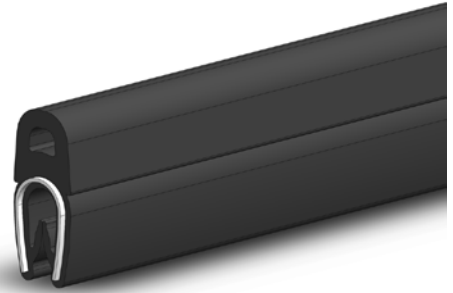

INFORMATION

Edge protection seal profiles GN 2182 can be used to seal doors, covers and hatches. The profiles are pressed by hand onto the front of metal sheets and plates. The embedded clamp insert prevents detachment. Glue or other adhesives are not required.

When assembled, the profile should deform slightly according to w_2 . This ensures an optimal seal. Adherence to the guideline placement radii (r_1 ... r_4) is recommended in order to ensure a tight profile seal and to make assembly easier.

TECHNICAL INFORMATION

- Technical information for edge protection profiles (see page 3)

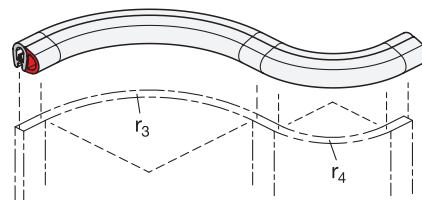
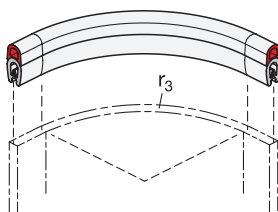
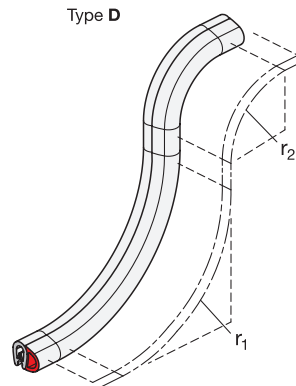
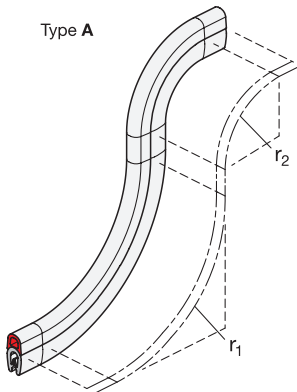

Type A

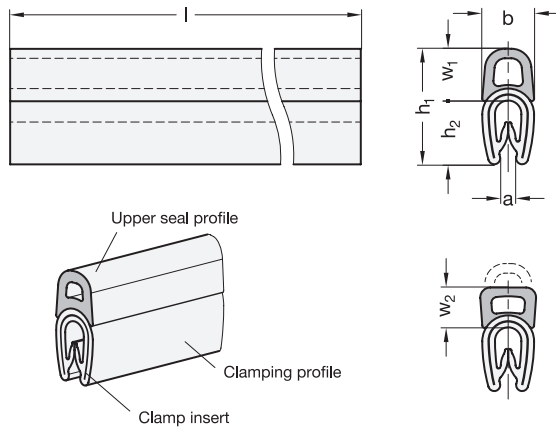

Type D

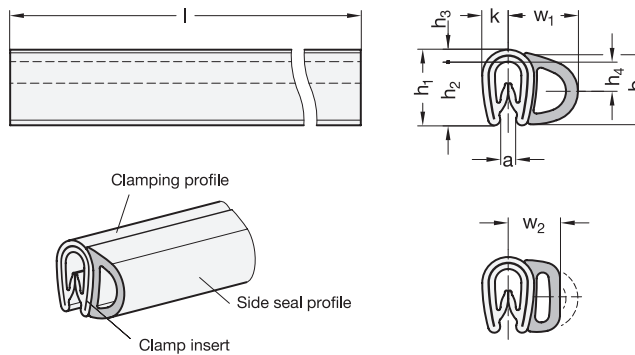

GN 2182

Description	h1	Cutting length l in m	a	b	h2	h3	h4	k	r1	r2	r3	r4	w1	w2 up to 50% permissible deformation	⚖
GN 2182-14,5-A-20	14,5	20	1 - 2	6,5	8	-	-	-	40	20	10	-	6,5	5,25	1650
GN 2182-14,5-A-50	14,5	50	1 - 2	6,5	8	-	-	-	40	20	10	-	6,5	5,25	4100
GN 2182-9,5-D-20	9,5	20	1 - 2	9	8	1,5	4	3,25	15	20	30	50	8,75	6,75	1650
GN 2182-9,5-D-50	9,5	50	1 - 2	9	8	1,5	4	3,25	15	20	30	50	8,75	6,75	4100

Edge protection profiles and edge protection seal profiles

Application examples - profiles in combination with other Eles+Ganter standard machine elements

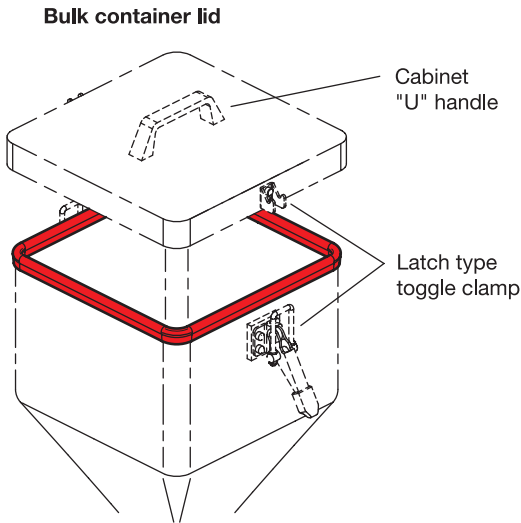
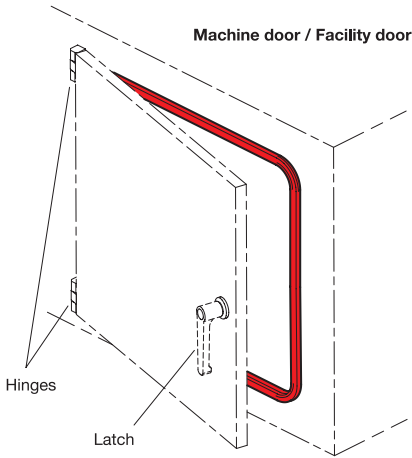

Application examples

With their versatility, edge protection profiles and/or edge protection seal profiles can be implemented in various applications, in conjunction with other Eles+Ganter products.

- Latches (see page 1462)
- Hinges (see page 1386)
- Toggle clamps (see page 1562)

Edge protection profiles and edge protection seal profiles

Construction example

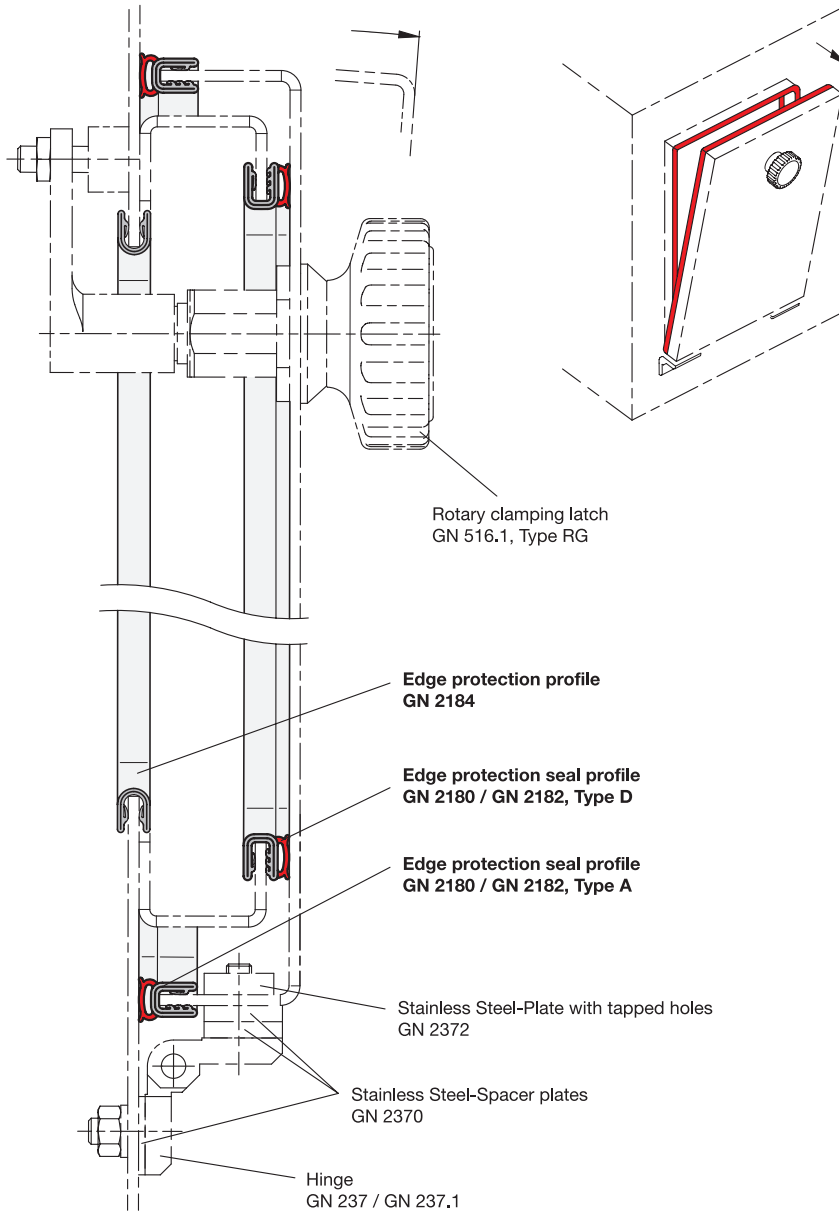

Construction examples

The construction depicted shows a standard application of edge protection profiles and edge protection seal profiles. The edge protection seal profiles are attached to the door and the fixed frame. The opening for the door is covered with an edge protection profile at its cut edge.

Edge protection profiles

Material PVC

SPECIFICATION

Profile

Polyvinyl Chloride (PVC)

- black **SW**
- Hardness 70 ±5 Shore A
- temperature resistant -40 °C to 90 °C
- weather exposure

Clamp insert

Steel clamping band

INFORMATION

Edge protection profiles GN 2184 are installed on the front edge of metal sheets and plates. They protect the surfaces from damage by sharp edges. The edge finish additionally achieves an optical decorative effect, while the need for potential further treatment such as burring and chamfering of cut or laser-cut metal sheets is reduced to an absolute minimum.

Adhering to the guideline placement radii ($r_1...r_3$) is recommended in order to guarantee permanent profile placement and to make assembly easier. Assembly can be carried out by hand, or alternatively with a soft-face hammer. The embedded clamp insert prevents it from detaching. Glue or other adhesive is not required.

TECHNICAL INFORMATION

- Technical information for edge protection profiles (see page 3)

ON REQUEST

- Color white / grey

Application examples

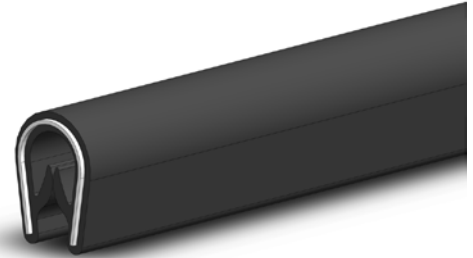

Cable duct / Socket duct

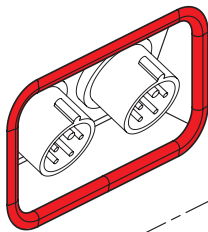

Cable duct

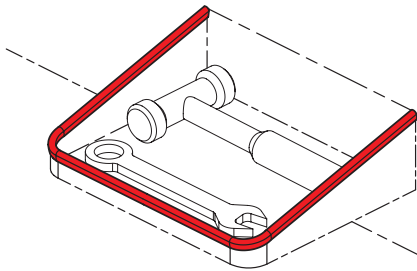
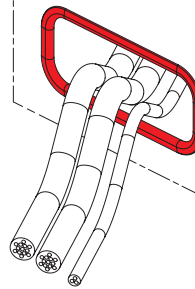

Tool tray

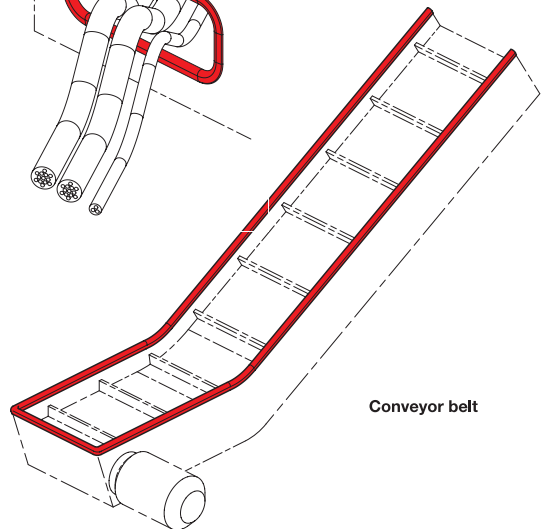

Conveyor belt

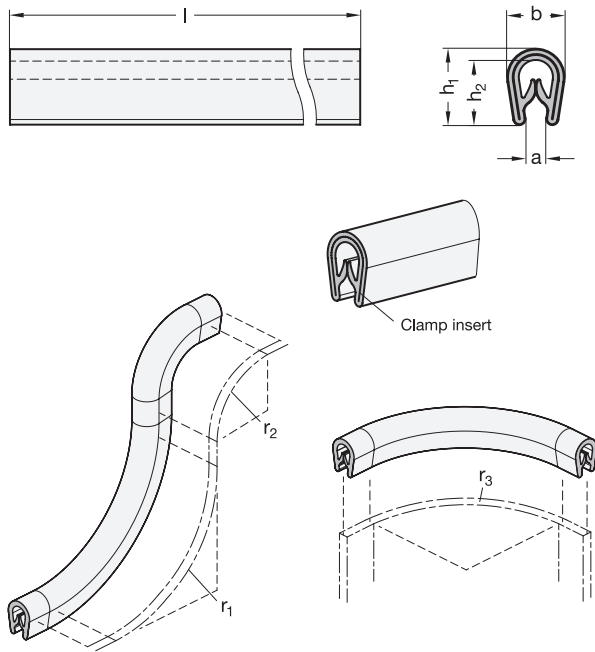

GN 2184

Description	h1	Cutting length l in m	a	b	h2	r1	r2	r3	⚖
GN 2184-9,5-SW-20	9,5	20	1 - 2	6,5	8	15	10	10	1500
GN 2184-9,5-SW-50	9,5	50	1 - 2	6,5	8	15	10	10	3500
GN 2184-14-SW-20	14	20	1 - 4	10,5	12	25	25	25	3000
GN 2184-14-SW-50	14	50	1 - 4	10,5	12	25	25	25	7350
GN 2184-15-SW-20	15	20	6 - 8	13	12,75	15	30	20	3450
GN 2184-15-SW-50	15	50	6 - 8	13	12,75	15	30	20	8600
GN 2184-17,5-SW-20	17,5	20	4 - 6	12,25	15,5	30	45	15	3950
GN 2184-17,5-SW-50	17,5	50	4 - 6	12,25	15,5	30	45	15	9800



Find out more on [elesa-ganter.com](https://www.elesa-ganter.com)

ELESA S.p.A.
Via Pompei 29
20900 Monza (MB)
Italy
+39 039 28 111
info@elesa.com
elesa.com

OTTO GANTER GmbH & Co.KG
Triburger Straße 3
78120 Furtwangen
Germany
+49 7723 65 07 0
info@ganternorm.com
ganternorm.com



**DESIGNED
FOR ENGINEERING**