

New

Pneumatically Operated Indexing Plungers

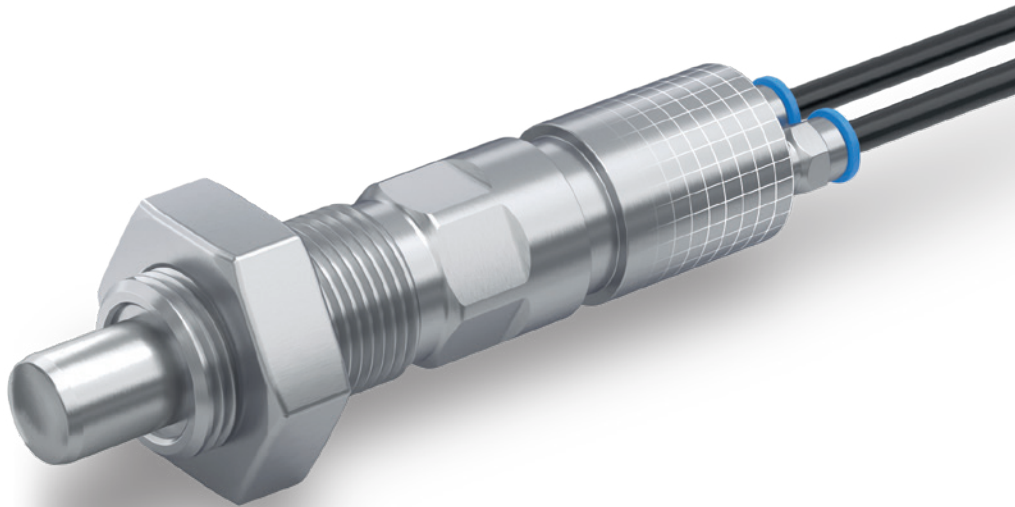

 **IO-Link**
inside

INOX
STAINLESS
STEEL



DESIGNED
FOR ENGINEERING





 **IO-Link**
inside

INOX
STAINLESS
STEEL

Stainless Steel Indexing Plungers

Pneumatically Operated

SPECIFICATION

Types

- Type **D**: Pneumatically double-acting, protrude / retract
- Type **A**: Pneumatically single-acting, retract by spring force
- Type **E**: Pneumatically single-acting, protrude by spring force

Coding

- **OP**: Without position query
- **BS0,4**: Position query on both sides, with plug, cable 0.4 m

Stainless steel AISI 303
Plunger pin surface hardened

Rod seal

Polyurethane PUR

Piston seal and O-ring

Acrylonitrile butadiene rubber (NBR)

Magnet

Neodymium, iron, boron (NdFeB)

Sensor

- Housing
Polyamide (PA), black
- Cable and plug
Outer sheath polyurethane (PUR), black

Sensor clip

Polyacetal (POM), black

Lock nut ISO 8675 (see page)

Stainless steel, AISI 304

INFORMATION

Stainless steel indexing plungers GN 817.7 with pneumatic operation can be easily and securely integrated into automated processes and can be positioned at locations where hand operation of the indexing plunger is not possible. Thanks to the material used, the indexing plungers are also suitable for more aggressive environments.

An integrated magnet allows the plunger pin position to be queried electronically by a sensor. The end limits (protruding and retracted position) are taught-in via the operating element on the sensor cable. They each send a high signal, which is indicated by the respective LED and can be processed by a machine control, for example.

The sensor electronics can also be accessed via IO-Link and offer the ability to set and read out the switching points and to block the teach button on the operating element. To avoid interference, no external magnetic fields should act on the indexing plunger. The pneumatic indexing plungers are supplied with a lock nut. With coding BS0,4, the sensor, sensor clip and an allen wrench are also supplied loose.

- Range of indexing plungers (see page 738)

ACCESSORY

- Cable with Connector GN 330 (see page 1448)



TECHNICAL INFORMATION

- IO-Link Device Description File
- Sensor Starting Operation
- IP Protection Classes (see page A23)
- ISO-Fundamental Tolerances (see page A21)
- Elastomer Characteristics (see page A32)
- Stainless Steel Characteristics (see page A26)

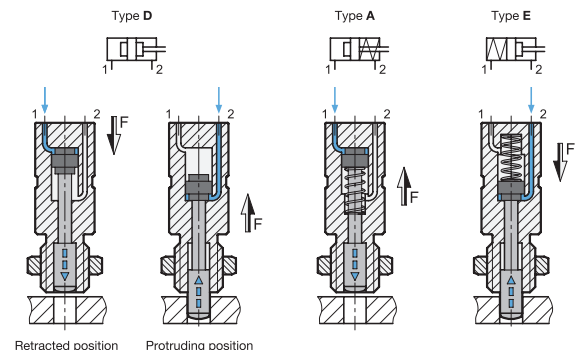
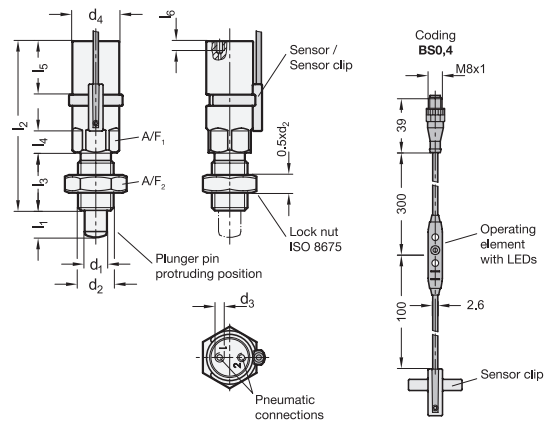

GN 817.7-D

STAINLESS STEEL

Description	d1 Pin -0.02/ -0.05 Bore H7	l1	d2	d3	d4	l2	l3	l4	l5	l6 min.	A/F 1	A/F 2	Force F at 6 bar in N≈ When protruding	Force F at 6 bar in N≈ When retracting	
GN 817.7-6-9-D-OP	6	9	M 12 x 1.5	M 3	21	73	22	10	24	4	19	18	65	50	176
GN 817.7-6-9-D-BS0,4	6	9	M 12 x 1.5	M 3	21	73	22	10	24	4	19	18	65	50	178
GN 817.7-8-12-D-OP	8	12	M 16 x 1.5	M 3	21	76	26	10	24	4	19	24	65	50	202
GN 817.7-8-12-D-BS0,4	8	12	M 16 x 1.5	M 3	21	76	26	10	24	4	19	24	65	50	205
GN 817.7-10-12-D-OP	10	12	M 16 x 1.5	M 3	21	76	26	10	24	4	19	24	65	50	205
GN 817.7-10-12-D-BS0,4	10	12	M 16 x 1.5	M 3	21	76	26	10	24	4	19	24	65	50	207
GN 817.7-12-15-D-OP	12	15	M 20 x 1.5	M 3	21	76	34	10	24	4	19	30	65	50	246
GN 817.7-12-15-D-BS0,4	12	15	M 20 x 1.5	M 3	21	76	34	10	24	4	19	30	65	50	248

GN 817.7-A

STAINLESS STEEL

Description	d1 Pin -0.02/ -0.05 Bore H7	l1	d2	d3	d4	l2	l3	l4	l5	l6 min.	A/F 1	A/F 2	Spring force F in N≈ Retracted	Spring force F in N≈ Protruding	
GN 817.7-6-9-A-OP	6	9	M 12 x 1.5	M 3	21	73	22	10	24	4	19	18	12	26	179
GN 817.7-6-9-A-BS0,4	6	9	M 12 x 1.5	M 3	21	73	22	10	24	4	19	18	12	26	181
GN 817.7-8-12-A-OP	8	12	M 16 x 1.5	M 3	21	76	26	10	24	4	19	24	12	26	205
GN 817.7-8-12-A-BS0,4	8	12	M 16 x 1.5	M 3	21	76	26	10	24	4	19	24	12	26	207
GN 817.7-10-12-A-OP	10	12	M 16 x 1.5	M 3	21	76	26	10	24	4	19	24	12	26	207
GN 817.7-10-12-A-BS0,4	10	12	M 16 x 1.5	M 3	21	76	26	10	24	4	19	24	12	26	209
GN 817.7-12-15-A-OP	12	15	M 20 x 1.5	M 3	21	76	34	10	24	4	19	30	12	26	248
GN 817.7-12-15-A-BS0,4	12	15	M 20 x 1.5	M 3	21	76	34	10	24	4	19	30	12	26	250

GN 817.7-E

STAINLESS STEEL

Description	d1 Pin -0.02/ -0.05 Bore H7	l1	d2	d3	d4	l2	l3	l4	l5	l6 min.	A/F 1	A/F 2	Spring force F in N≈ Retracted	Spring force F in N≈ Protruding	
GN 817.7-6-9-E-OP	6	9	M 12 x 1.5	M 3	21	73	22	10	24	4	19	18	26	12	177
GN 817.7-6-9-E-BS0,4	6	9	M 12 x 1.5	M 3	21	73	22	10	24	4	19	18	26	12	179
GN 817.7-8-12-E-OP	8	12	M 16 x 1.5	M 3	21	76	26	10	24	4	19	24	26	12	203
GN 817.7-8-12-E-BS0,4	8	12	M 16 x 1.5	M 3	21	76	26	10	24	4	19	24	26	12	205
GN 817.7-10-12-E-OP	10	12	M 16 x 1.5	M 3	21	76	26	10	24	4	19	24	26	12	215
GN 817.7-10-12-E-BS0,4	10	12	M 16 x 1.5	M 3	21	76	26	10	24	4	19	24	26	12	217
GN 817.7-12-15-E-OP	12	15	M 20 x 1.5	M 3	21	76	34	10	24	4	19	30	26	12	246
GN 817.7-12-15-E-BS0,4	12	15	M 20 x 1.5	M 3	21	76	34	10	24	4	19	30	26	12	248

Assembly Instructions



The radial position of the sensor cable can be freely determined when installing the sensor clip.

Installation steps:

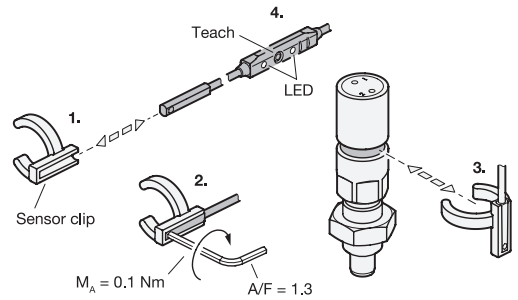
1. Insert the sensor into the sensor clip from the side.
2. Tighten the hexagon socket screw of the sensor.
3. Clip the sensor clip into the ring groove of the indexing plunger and then adjust the position by turning, if necessary.
4. During commissioning, teach the sensor to the end positions via the operating element or IO-Link in accordance with the operating instructions supplied with the sensor.



Pneumatic properties	
Operating pressure	4 - 6 bar
Operating medium	Filtered, dried air, unoled or oiled
Temperature range	-20 °C ... +80 °C

Electrical Properties of the Sensor	
Output function	2x normally open (NO)
Output type	2x PNP
Supply voltage	12 - 30 V DC
Continuous current I_a	≤ 100 mA
Connection type	4-pole connector M8x1, freely rotating with knurled screw connection
Protection type	IP 67
Power consumption	≤ 15 mA
Voltage drop	≤ 2.2 V
Protection class	III
Temperature range	-20 °C ... +75 °C
Shock and vibration resistance	30 g, 11 ms / 10 ... 55 Hz, 1 mm
EMV	According to EN 60947-5-2
Reverse polarity protection	Yes
Short-circuit protection	Yes
Activation impulse suppression	Yes
Communication interface	IO-Link (V1.0) Cycle time 2.3 ms Process data length 2 bits Process data structure: Bit 0 = Switching signal Q ₁ Bit 1 = Switching signal Q ₂ Bit 2...7 = Empty
Approvals, conformity declarations	 

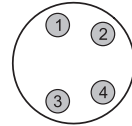
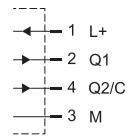

COPYRIGHT © 2022

Elesa S.p.A and OTTO GANTER GmbH & Co. KG

All rights reserved.

No part of this catalogue can be reproduced in whole
or in part without prior written permission from

Elesa S.p.A or OTTO GANTER GmbH & Co. KG



Find out more on [elesa-ganter.com](https://www.elesa-ganter.com)

ELESA S.p.A.
Via Pompei 29
20900 Monza (MB)
Italy
+39 039 28 111
info@elesa.com
[elesa.com](https://www.elesa.com)

OTTO GANTER GmbH & Co.KG
Tribberger Straße 3
78120 Furtwangen
Germany
+49 7723 65 07 0
info@ganternorm.com
[ganternorm.com](https://www.ganternorm.com)



DESIGNED
FOR ENGINEERING