

# Technical Meeting Tubular Linear motors

# Agenda

- 1. NiLAB Product Lines**
- 2. Tubular Linear motor technology background**
  - a) How it is works**
  - b) Linear motor structure**
  - c) Enclosure types**
  - d) Special version**
  - e) Accessories**
- 3. How to size an application:**
  - a) Websmart**
  - b) Pneumatic to electric conversion tool**
  - c) Application example**
- 4. Motor + Drive + PLC combination**
  - a) Commisioning the motor and the drive**
  - b) Programming PLC (Quick example)**

# Product Lines



GD Tubular Linear motors  
Linear stages  
Robotics



L series Ironcore Linear motors  
LK serie with water cooling  
R series reversed Ironcore



GDP and GDM Linear stages

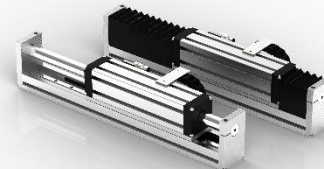

NL Miniature Tubular Linear motors

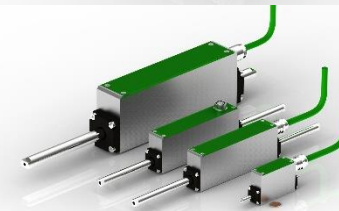



# HISTORY OF EU Linear motor evolution

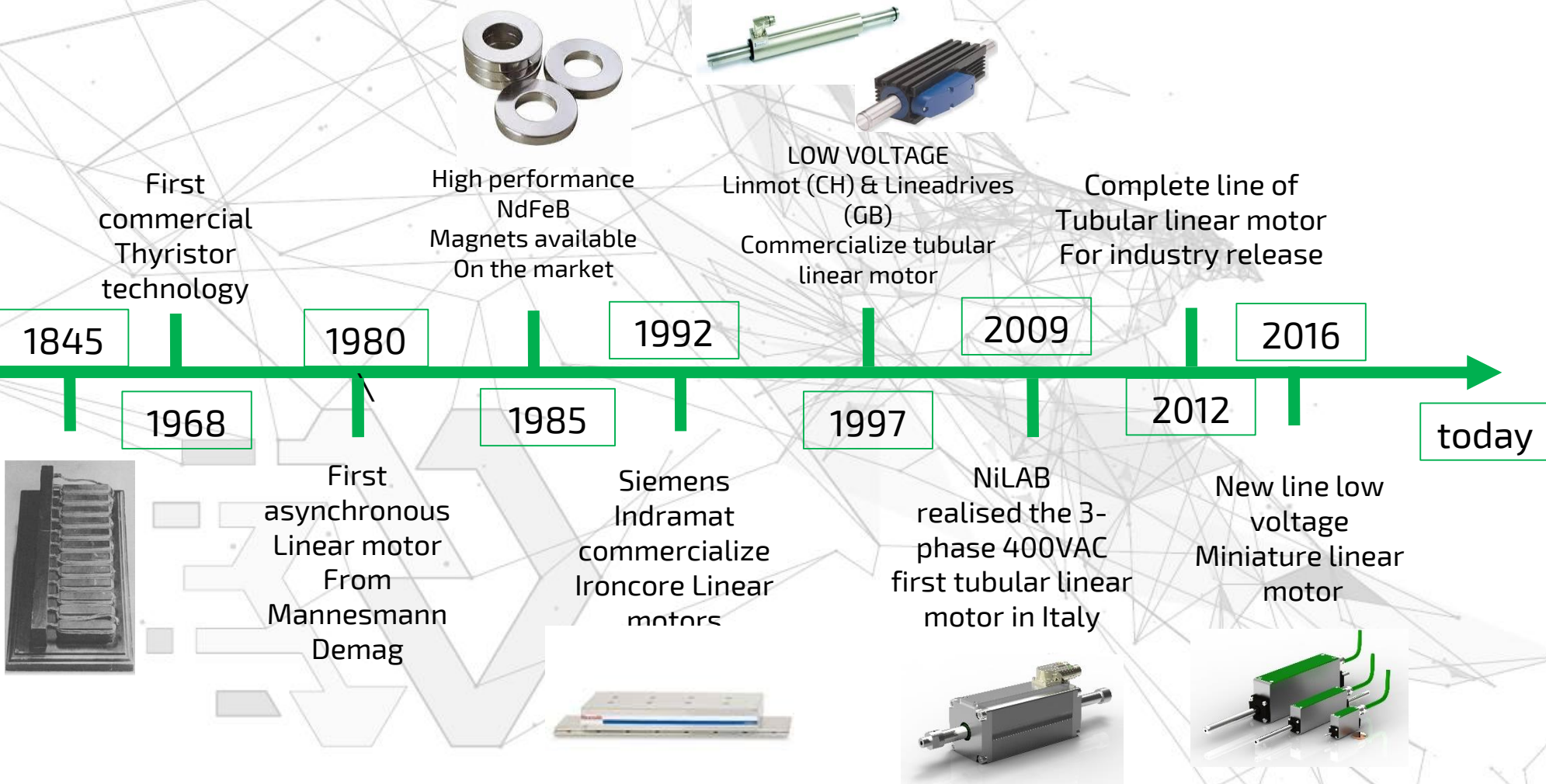

# TECHNOLOGY BACKGROUND

## Linear motor tree

### LINEAR MOTOR

Synchronous

Asynchronous

Ironless

Ironcore

Ironcore

Flat bed

Tubular

U-shaped

Tubular

Flat bed

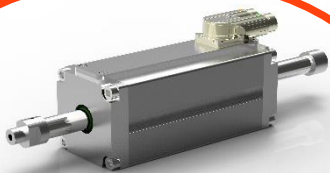

# TECHNOLOGY BACKGROUND

## from rotary to linear / tubular linear

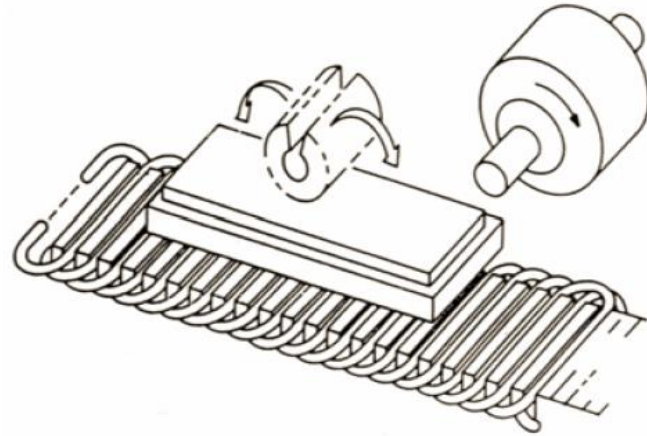

Iron Lamination or plastic support for coil

Magnets

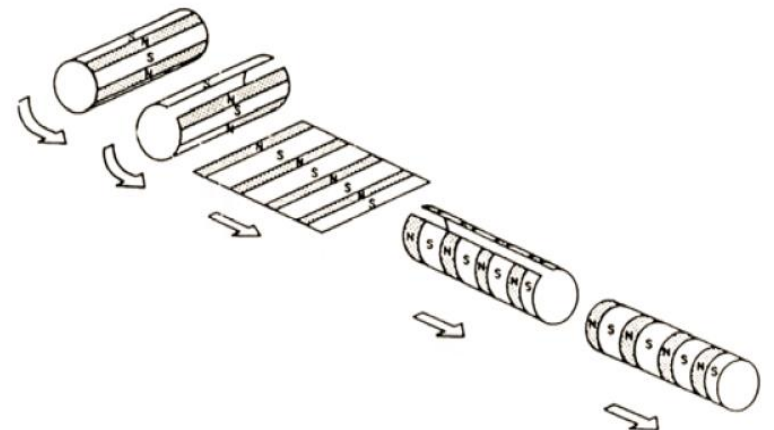
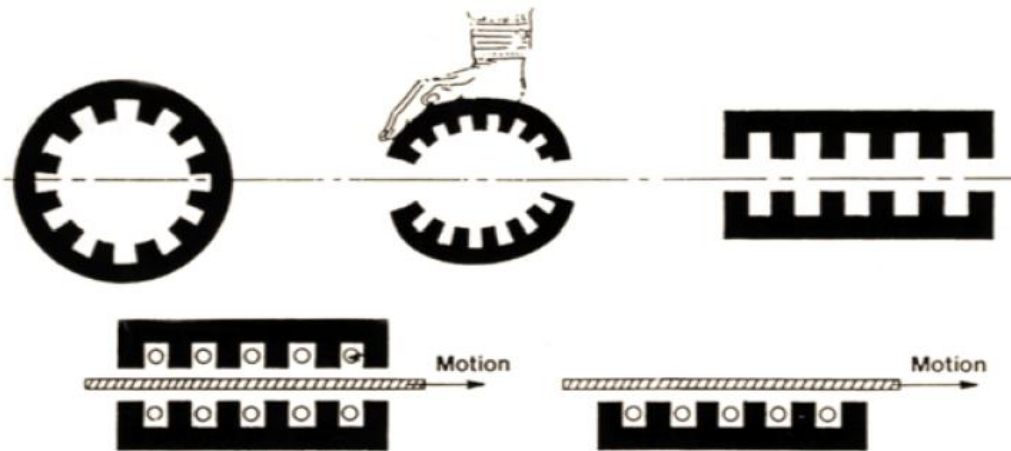



# TECHNOLOGY BACKGROUND



FORCER



ROD

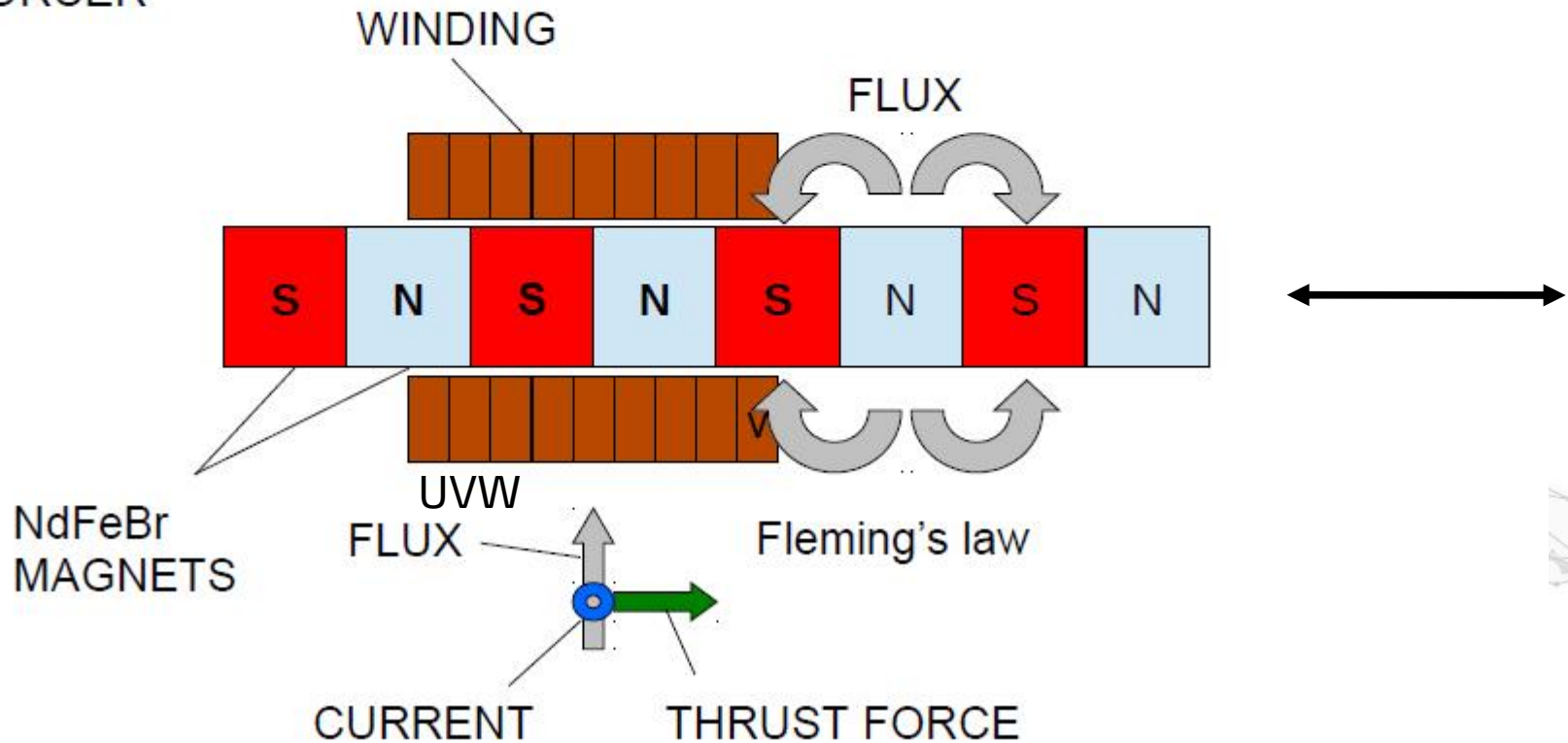

Rotatable connector for signal and power

Class H three phase windings  
No contact between slider and coil  
Large airgap

Integrated Encoder

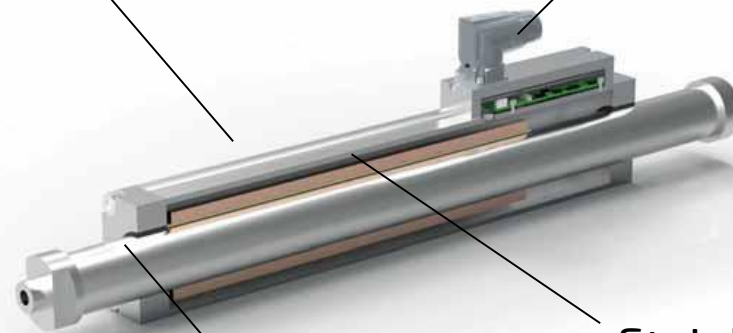
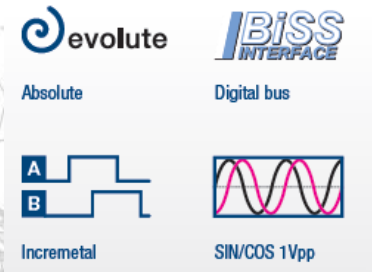

Stainless Steel AISI 304 shaft  
With NdFeBr permanent magnets

Igus X series  
Linear bearing on flange  
(replacable)





# MOTOR ENCLOSURE TYPE STANDARD



## MOUNTING WITH NUTS



**GD16**

**GD25**

**GD35**



**2,5 Kg  
Cont Force**



**10 Kg  
Cont Force**



**30 Kg  
Cont Force**

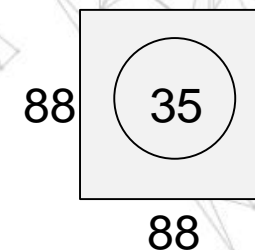
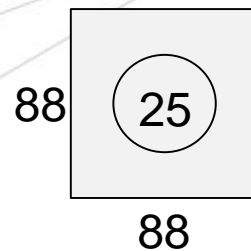
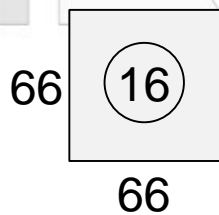

# MOTOR ENCLOSURE TYPE ISO



**GDI25 / GDI35**

**10 Kg / 30 Kg  
Cont Force**

**GDI16**

**2,5 Kg  
Cont Force**

**GDI16**

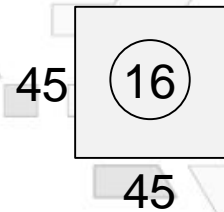

**GDI25**

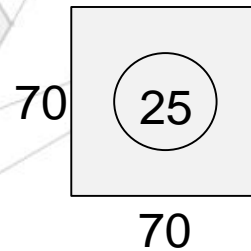

**GDI35**

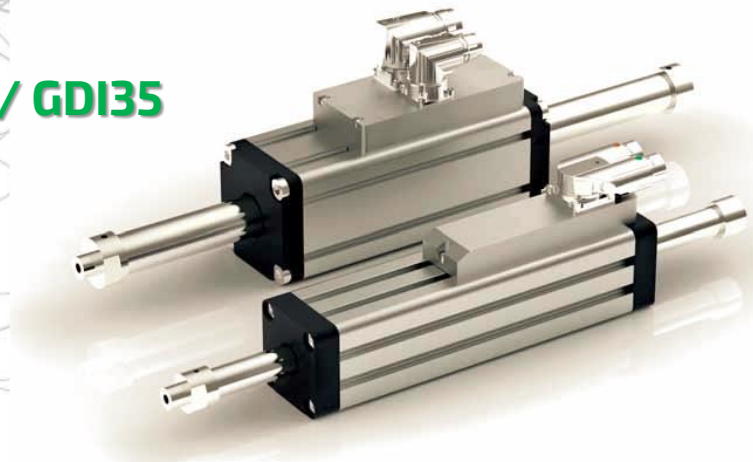
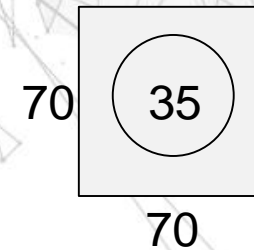

# SPECIAL MODELS



**HYGIENIC**

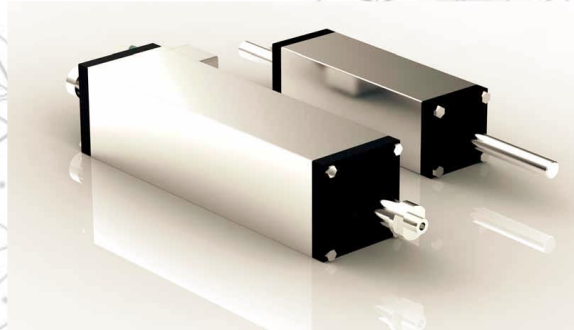

**UNDER DEVELOPMENT  
FOR FOOD APPLICATION  
WASH DOWN**

**ROTOLINEAR**

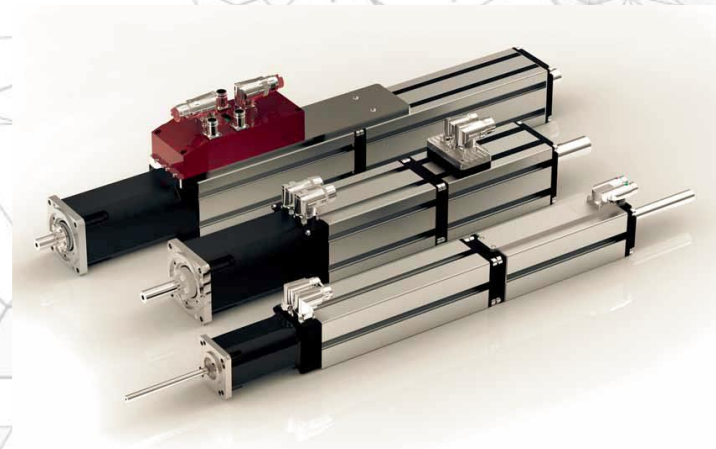

**CAPPING,  
DRILLING  
INDEPENDENT MOTION  
LINEAR + ROTARY**

**LINEAR  
POSITIONER**

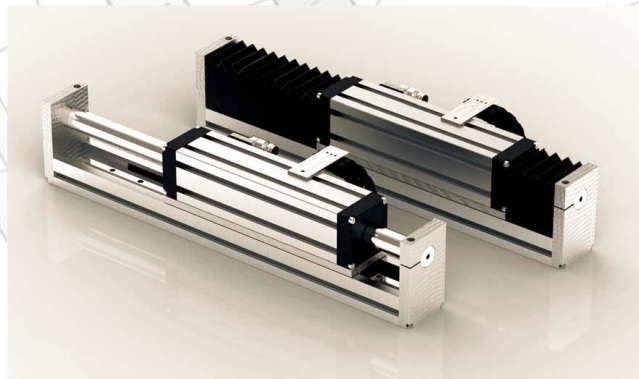

**COMPLETE AXIS  
WITH LINEAR GUIDE  
ENCODER  
CABLE CHAIN**



# SPECIAL MODELS



**PICK AND PLACE  
ROBOT**

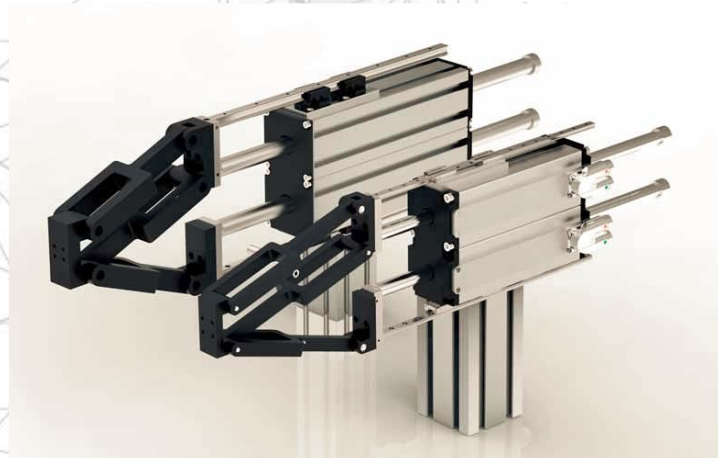

**UPTO 5 Kg  
150-200  
PICK PER MINUTES**

**WATER COOLED  
FOR EXTREME  
HIGH DUTY  
APPLICATION**

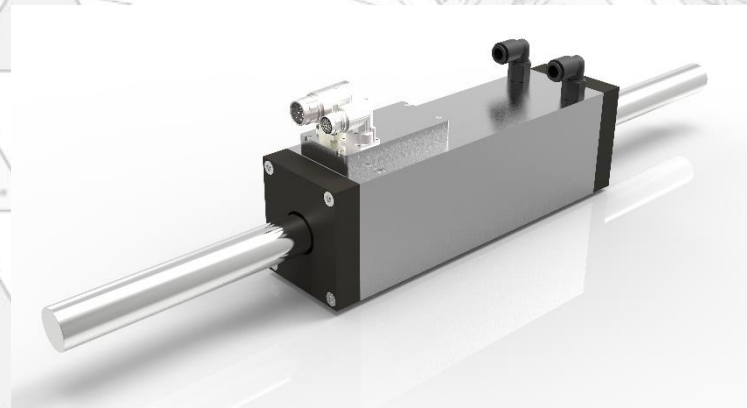

**UPTO 50 Kg  
CONTINUOUS  
FORCE**

# FULL SET OF MECHANICS ACCESORIES



M5, M6 & M8 NUTS FOR FIXING  
USING T-SLOTS

The image shows a hand using a screwdriver to insert a metal nut into a T-slot on a metal plate. To the left of this image, there are three individual nuts of different sizes (M5, M6, and M8) and a small metal plate with a T-slot.

LINEAR COUPLING FOR PERFECT  
ALIGNMENT BETWEEN ROD AND  
PAYLOAD

The image shows a black linear coupling device with a silver rod passing through it. The coupling has a central section that allows for slight misalignment between the rod and the payload, ensuring smooth movement.

ANTIROTATION MECHANICS  
BASED ON LINEAR GUIDE

The image shows a long, silver linear guide assembly with a black end cap. It features a central rod and a sliding carriage with a locking mechanism to prevent rotation.

PNEUMATIC BRAKE FOR VERTICAL  
APPLICATION

The image shows a pneumatic brake assembly with a black body and silver components, designed for vertical applications. It includes a piston and a spring mechanism to provide controlled braking.

# FULL SET OF ELECTRIC ACCESORIES



**FAN COOLING FOR HIGH DUTY APPLICATION**



**Y-TEC CABLES  
READY TO BE USE WITH STANDARD  
SERVO DRIVE**



**SPEEDTEC CABLES  
READY TO BE USE WITH STANDARD  
SERVO DRIVE**



# BUNDLE SERVO DRIVES



CANopen®

EtherCAT®



**MBD SERVODRIVE**  
230 VAC or 3x400VAC  
3,6 & 12 Amps rated  
CANOPEN DS402  
ETHERCAT (COE)

CANopen®



**TBS1 SERVODRIVE**  
24/48 VDC  
CANOPEN DS402

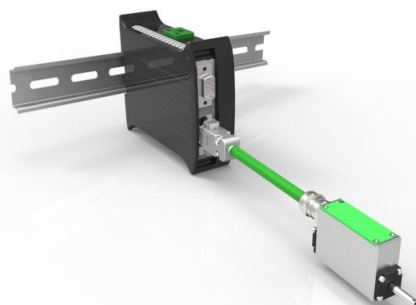

**UNDER DEVELOPMENT**  
**MICRO SERVODRIVE**  
24/48 VDC  
**FOR DIN RAIL MOUNTING**

# Market dimension

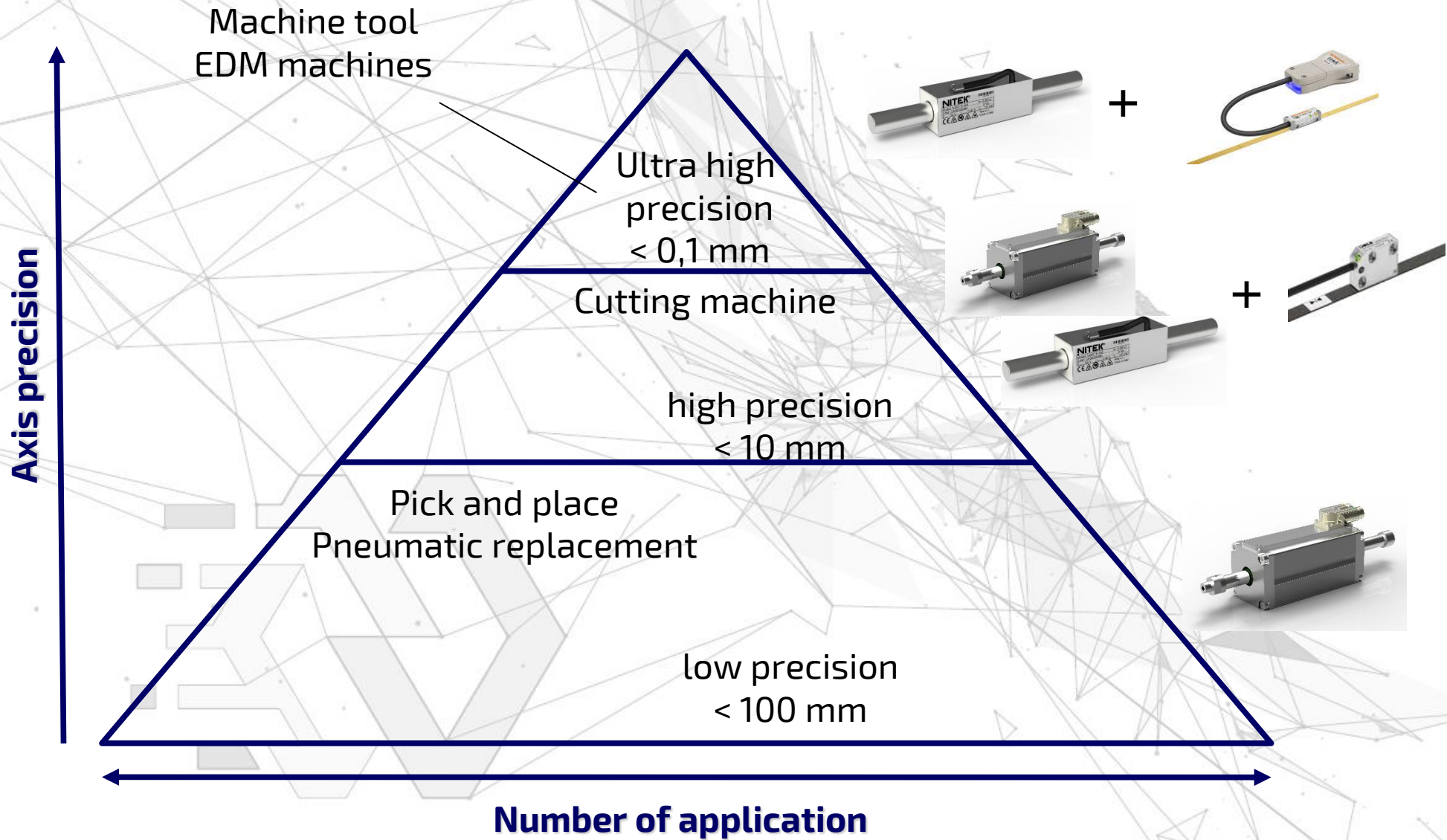

# PRODUCT LINE

from building block to complete systems



**Robotics**

Green Picker 2D  
Green Picker Linear Delta 3D/4D  
Green Drive Gantry 2D

**Complete system**

**P&P  
Single  
Axis**

Green Drive Standard  
Green Drive ISO  
Green Drive Hygienic  
Green Drive Rotolinear  
Green Drive Stage

**Complete actuator**

**Single  
Axis  
Mfg**

Green Drive N series  
L series flat ironcore

**Building block**

**Complete machine**





# Industries Served



## Food



## Wood



## Beverage

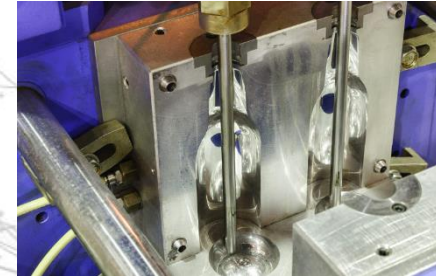

## Pharma & medical



## Paper



## CNC Machines



## Electronics



## Portable Device



## Semiconductor

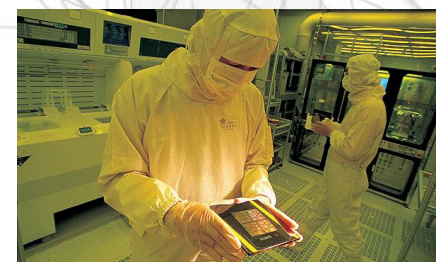



# Think Electric

**Our Motto**