

THERMIC-WELDED COVERS

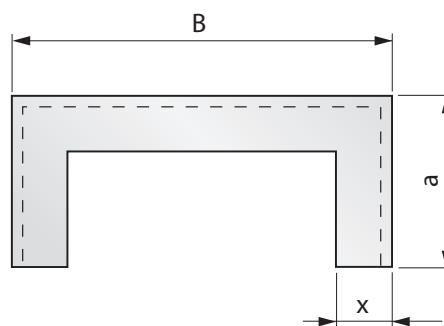
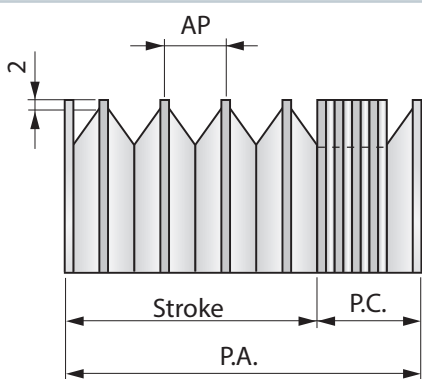
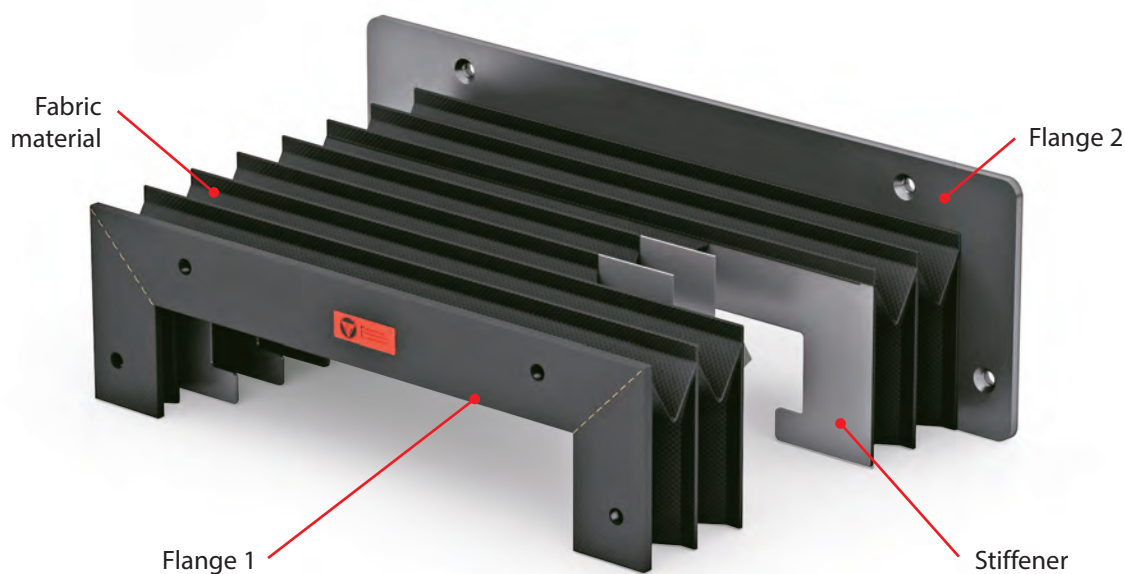

P.A. = Open length
P.C. = Closed length
Stroke = Open length - closed length

B = Outside width
a = Outside height
x = Fold height

Formula for calculating the CLOSED LENGTH

AP = Opening of 1 fold = $x \cdot 2 - 8$

SM = Fabric thickness *

SS = Stiffener thickness *

SF = Flange thickness *

NP = Number of folds = $\frac{P.A.}{AP} + 2$

P. C. = $(SM \cdot 8 + SS) \cdot NP + (SF \cdot 2)$

* See materials list on page 31.

This data sheet shows only one type of Thermic-Welded Cover that we manufacture.

Contact our engineering department for other types.

Example:

Given that: Fold height = 15 mm

Open length = 1000 mm

Opening of 1 fold = $15 \times 2 - 8 = 22$

Number of folds = $\frac{1000}{22} + 2 = 48$

Closed length = $(0,25 \times 8 + 1^{**}) \times 48 + (2^{***} \times 2)$

Closed length = $3 \times 48 + 4 = 148$

Closed length = 148 mm

* We hypothesize the fabric material with code "TEMAT015" (see materials list on page 31)

** We hypothesize that the stiffener is 1 mm thick

*** We hypothesize that the flange is 2 mm thick (see materials list on page 31)



THERMIC-WELDED COVER WITH FIXED LAMINATIONS

Working position:

- Horizontal
- Vertical
- Frontal

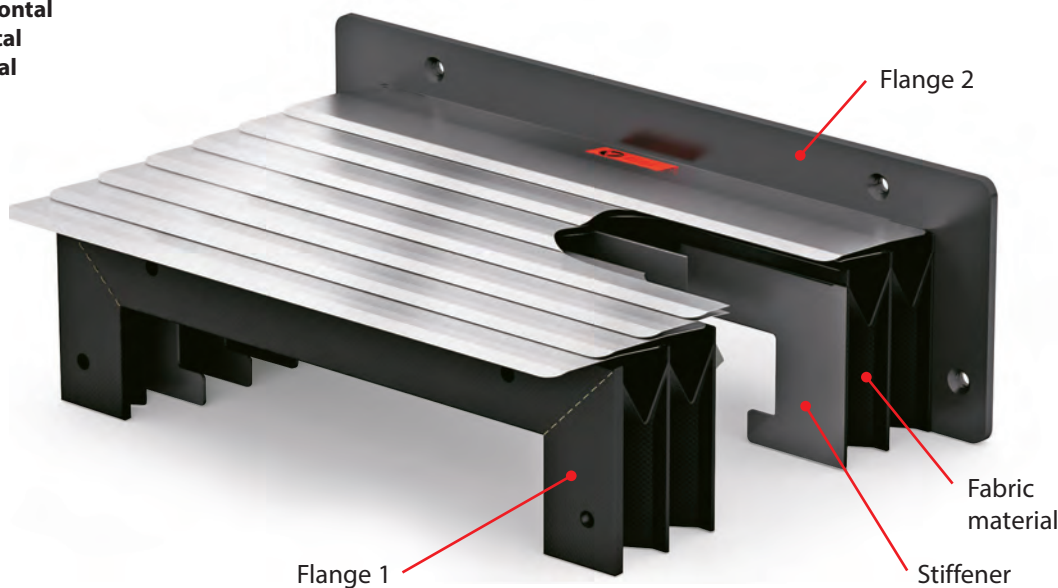

Possible special fixing to facilitate the mounting of the first steel lamination

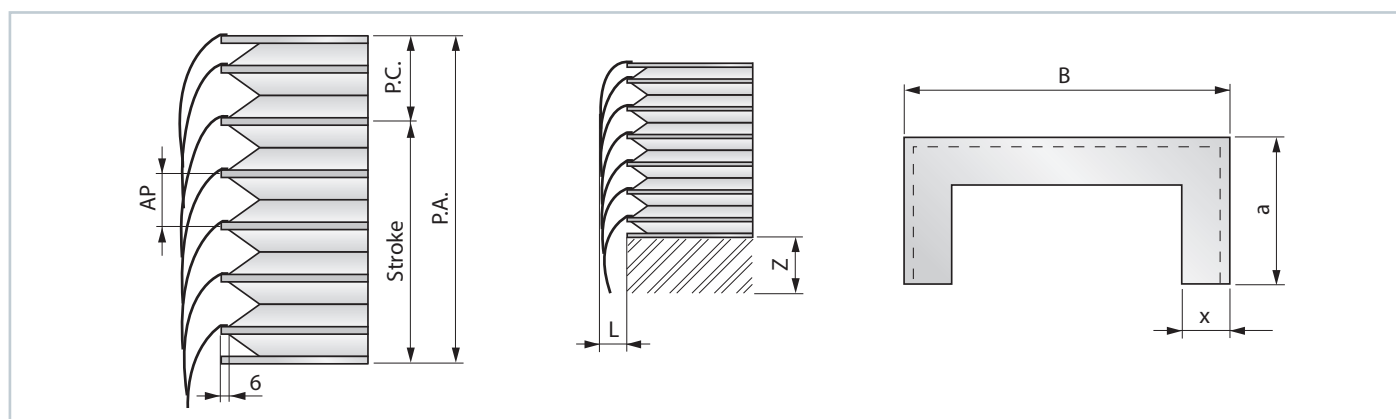
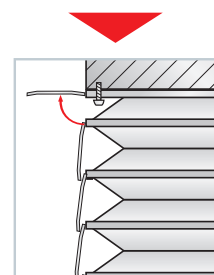

- P.A.** = Open length
- P.C.** = Closed length
- Stroke** = Open length - closed length
- B** = Outside width
- a** = Outside height
- x** = Fold height

x(mm)	15	20	25	30	35	40	45
L(mm)	16	21	26	33	43	48	56
Z(mm)	45	55	65	75	85	95	105

Formula for calculating the CLOSED LENGTH

- AP** = Opening of 1 fold = $x \cdot 2 - 16$
- SM** = Fabric thickness *
- SS** = Stiffener thickness *
- SF** = Flange thickness *
- NP** = Number of folds = $\frac{P.A.}{AP} + 2$
- P. C.** = $(SM \cdot 8 + SS) \cdot NP + (SF \cdot 2)$

* See materials list on page 31

This data sheet shows only one type of Thermic-Welded Cover that we manufacture.

Contact our engineering department for other types.

Example

- Given that: Fold height = 45 mm
- Open length = 1800 mm
- Opening of 1 fold = $45 \times 2 - 16 = 74$
- Number of folds = $\frac{1800}{74} + 2 = 27$
- Closed length = $(0,35^* \times 8 + 1^{**}) \times 27 + (3^{***} \times 2)$
- Closed length = $3,8 \times 27 + 6 = 109$
- Closed length = 109 mm**

- * We hypothesize the fabric material with code "TEMAT151" (see materials list on page 31)
- ** We hypothesize that the stiffener is 1 mm thick
- *** We hypothesize that the flange is 3 mm thick (see materials list on page 31)

THERMIC-WELDED COVER WITH FLEXIBLE LAMINATIONS

Vertical working position only

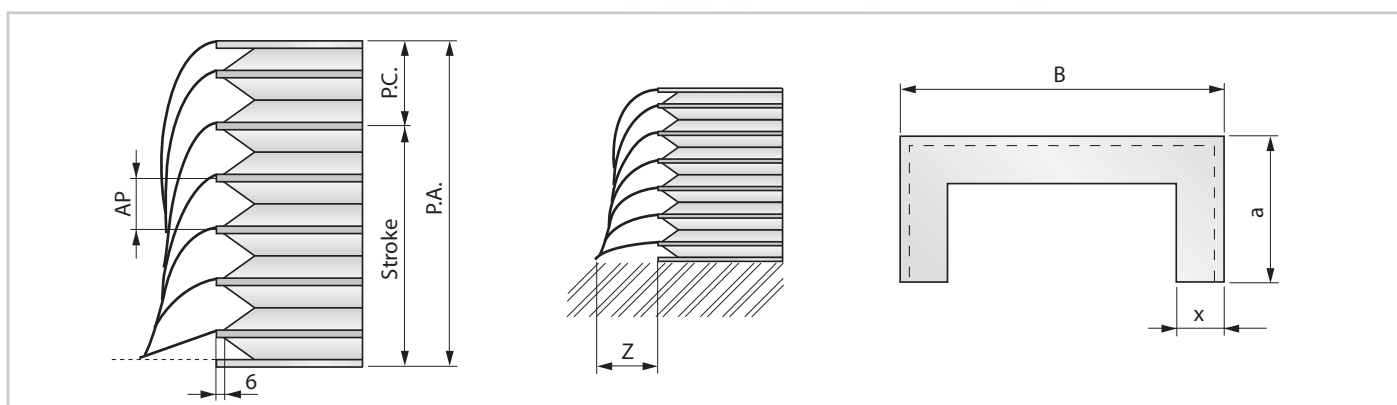

P.A. = Open length
P.C. = Closed length
Stroke = Open length - closed length

B = Outside width
a = Outside height
x = Fold height

x(mm)	15	20	25	30	35	40	45
Z(mm)	40	50	60	70	80	90	100

Formula for calculating the CLOSED LENGTH

Opening of 1 fold = $(x \cdot 2) - 16$

SM = Fabric thickness *

SS = Stiffener thickness *

SF = Flange thickness *

NP = Number of folds = $\frac{P.A.}{AP} + 2$

P. C. = $(SM \cdot 8 + SS) \cdot NP + (SF \cdot 2)$

* See materials list on page 31

This data sheet shows only one type of Thermic-Welded Cover that we manufacture.

Contact our engineering department for other types.

Example

Given that: Fold height = 30 mm
 Open length = 1000 mm

Opening of 1 fold = $(30 \times 2) - 16 = 44$

Number of folds = $\frac{1000}{44} + 2 = 25$

Closed length = $(0,25 \times 8 + 1^{**}) \times 25 + (2^{***} \times 2)$

Closed length = $3 \times 25 + 4 = 79$

Closed length = 79 mm

* We hypothesize the fabric material with code "TEMAT015" (see materials list on page 31)

** We hypothesize that the stiffener is 1 mm thick

*** We hypothesize that the flange is 2 mm thick (see materials list on page 31)

Reproduction of this page is strictly prohibited.



Thermic-Welded Cover materials

Fabric material code	Description			Thickness (mm)	Heat resistance			Primary resistance characteristics
	Visible side	Fabric insert	Internal side		Momentary contact °C	Continuous		
						min. °C	max. °C	
TEMAT 106	Ptfe	Polyester	Polyurethane	0,30	+200	-30	+120	Excellent resistance to oils and chemical products. No adhesive surface. Low friction coefficient. Excellent chemical inertia. Excellent resistance to abrasion and bending strength. Mainly used in grinding machines.
TEMAT 015	Polyurethane	Polyester	Polyurethane	0,25	+200	-30	+ 90	Excellent resistance to petroleum products, oils and heavy abrasion. Excellent bending strength.
TEMAT 151	Polyurethane	Polyester	Polyurethane	0,35	+200	-30	+ 90	
TEMAT 164	Polyurethane	Kevlar*	Polyurethane	0,35	+350	-30	+180	Excellent resistance to petroleum products, oils and heavy abrasion. Excellent bending strength. Excellent mechanical strength. Kevlar also has excellent shear strength. Normally used when there is heavy mechanical stress, a large amount of sharp shavings, and at high temperatures.
TEMAT 165	Polyurethane	Nomex*	Polyurethane	0,36	+300	-30	+130	Excellent resistance to petroleum products, oils and heavy abrasion. Excellent bending strength. Excellent mechanical strength. Good resistance to minor welding splatter or hot material. Widely used in laser cutting machines. Self-extinguishing.
TEMAT 169	Polyurethane	Panox*/Kevlar	Polyurethane	0,33	+300	-30	+130	Excellent resistance to petroleum products, oils and heavy abrasion. Excellent bending strength. Excellent mechanical strength. Good resistance to minor welding splatter or hot material. It may be considered as the best fabric on the market for use in laser cutting machines. Self-extinguishing.
TEMAT 017	PVC	Polyester	PVC	0,36	+100	-30	+ 70	Mainly used around heavy ambient dust, minor splatters of coolant and oil. Also suitable for use around acids.
TEMAT 020	PVC	Polyester	PVC	0,25	+100	-30	+ 70	

Reproduction of this page is strictly prohibited.

Stiffener materials

Stiffener material code	Description	Thickness (mm)	Notes
PVC 05	PVC	0,50 **	Outside width (B) up to 300 mm
PVC 10	PVC	1,00	Outside width (B) from 301 up to 700 mm
PVC 15	PVC	1,50	Outside width (B) from 701 up to 1500 mm

Flange materials

Flange material code	Description	Thickness (mm)
AL	Aluminum	2,0 - 3,0
AC	Steel	2,0 - 3,0 - 4,0
PVC	PVC	2,0 - 3,0

Lamination materials

Lamination material code	Description	Primary applications
AL	Aluminum (Baked Enamel Finish)	For use around welding splatter, small and medium-sized hot shavings. Especially suitable for use around continuous sparks. Appropriate where lightweight materials are necessary.
INOX	Stainless Steel	In work environments with large shavings. Especially suitable for use around acids.

* Kevlar and Nomex are registered Dupont trademarks ** NOT recommended for Thermic-Welded Covers with laminations.

Contact our engineering department for other materials and applications.

Standard Shapes

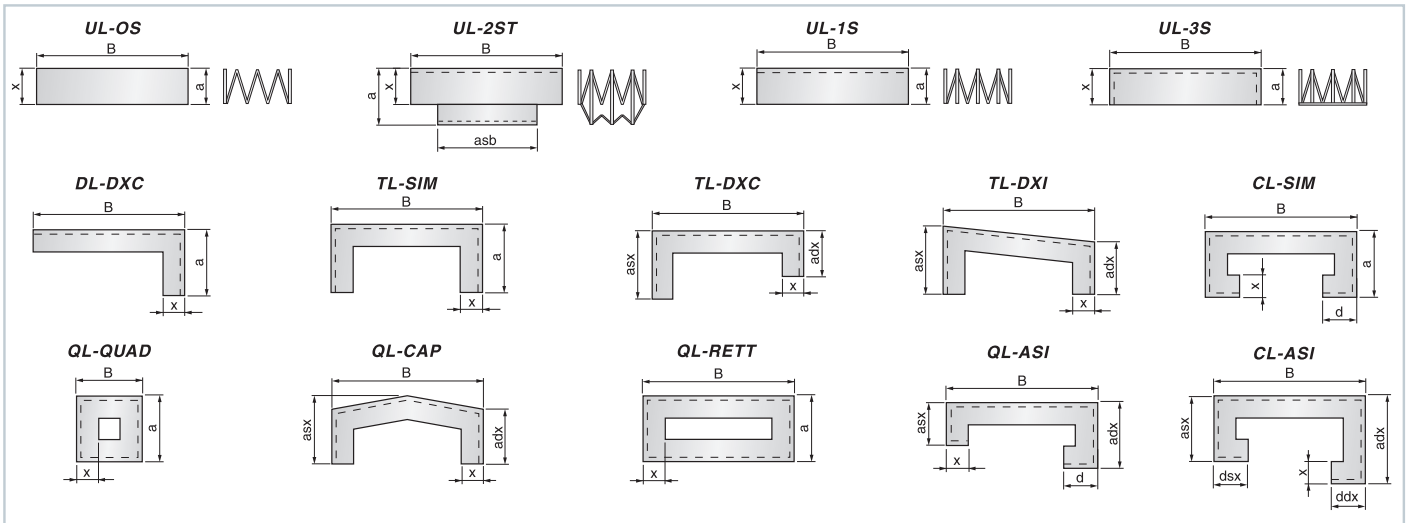

NOTE: The above are only the standard shapes of Thermic-Welded Covers. Other shapes available upon request.

Flange Fastening Systems

- Solution with sheet steel, aluminum or PVC flange
- Shape and holes per customer drawings

Type A

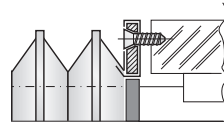

Type I

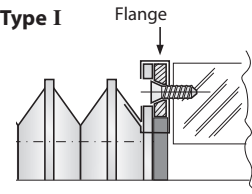

- Solution with sheet steel, aluminum or PVC flange
- Shape and holes per customer drawings
- Solution with connector flange protruding from the cover profile, made of sheet steel, aluminum or PVC

Type B1

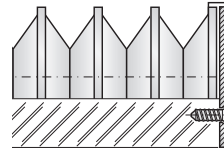

Type B2

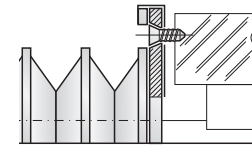

- Solution with sheet steel flange
- Shape and holes per customer drawings
- Threaded flange holes

Type C

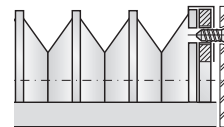

Solution with rapid VELCRO connection. A PVC support acts as a flange, with VELCRO strips applied to the stiffener and directly to the machine.

This solution offers:

- Rapid application and removal of the cover
- Low cost

Recommended for dry work environments

Type E

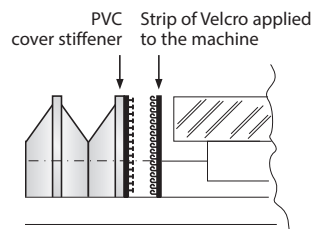

Type H

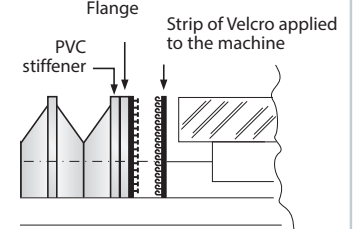

Solution with STRONG HOLD rapid connection. A PVC support and flange act as a flange, to which the STRONG HOLD rapid connection is applied. The flange is made of sheet steel, aluminum or PVC, shape and holes per customer drawings. This solution offers:

- Rapid application and removal of the cover
- Foam gasket strip provides a tight seal around the connection

Recommended for wet work environments

Type F

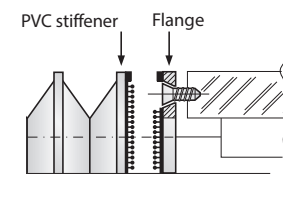

Type G

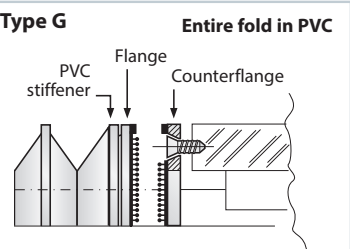

Entire fold in PVC

BELLOWS FOR HOISTING PLATFORM

- Prevention of impediment of the hoist pantograph
- Protection from dust, dirt or foreign particles

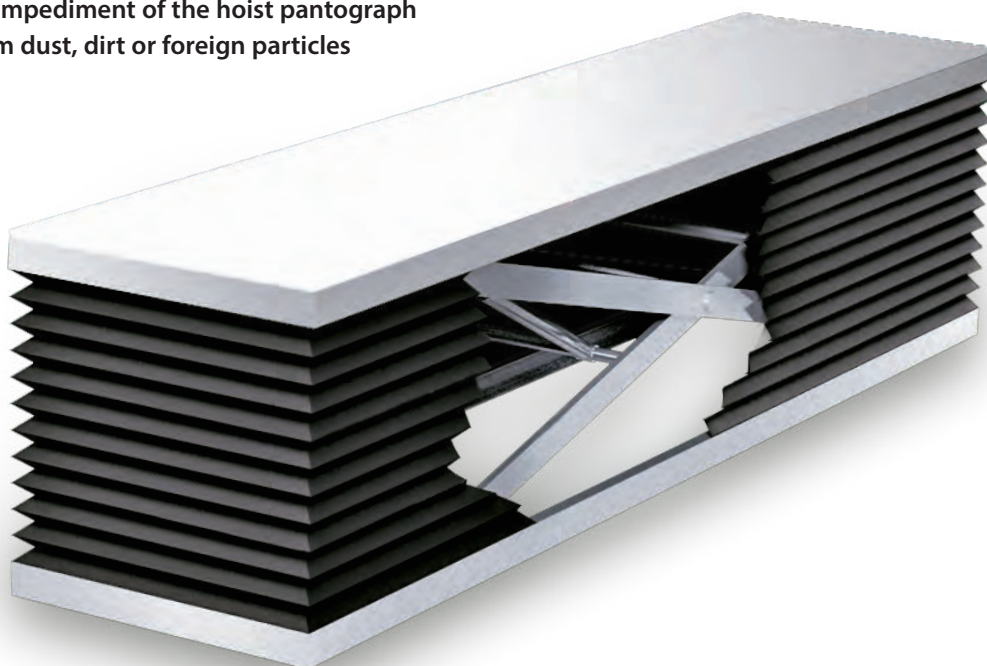

Systems for fastening Bellows for Lift Tables

I

Solution with sheet steel, aluminum or PVC flange. Shape and holes per customer drawings.

B

Solution with sheet steel, aluminum or PVC flange. Shape and holes per customer drawings.

E

Solution with rapid VELCRO connection. This solution offers:

- Rapid application and removal of the cover
- Low cost

CI

Bellows inner collar. Suitable for screw fastening.

CE

Bellows outer collar. Suitable for screw fastening.

EXAMPLES OF APPLICATION:

- Closing of upright doors
- Closing of storehouse rooms and interspaces
- Protection of level changing in assembly lines of the manufacturing industry
- Base protection of medical equipment

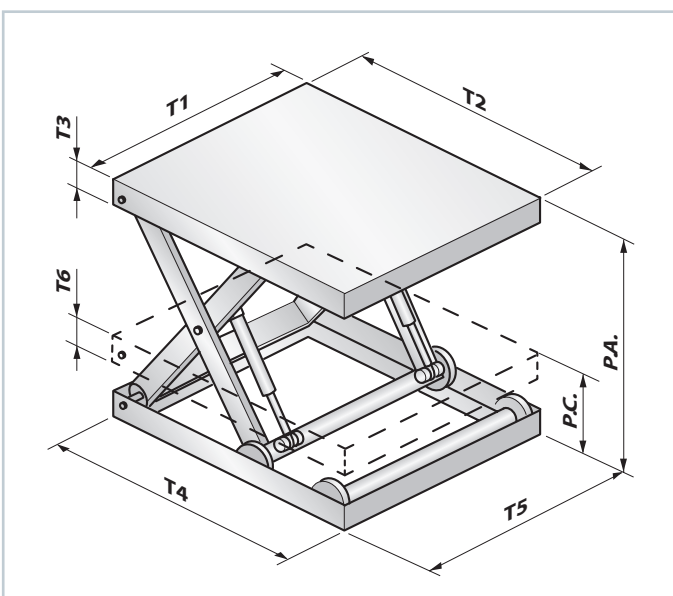

Questionnaire for HOISTING PLATFORMS:

T1 = mm

T2 = mm

T3 = mm

T4 = mm

T5 = mm

T6 = mm

P.A. = mm

P.C. = mm

NP = mm

Upper side fastening I B E CI CE

Lower side fastening I B E CI CE

NOTE: The data fields and/or tables marked by are the least ones to be filled in order to give you a quotation. Please send an e-mail to info@pei.eu or a fax to +39 051 6464840.

Reproduction of this page is strictly prohibited.



BELLOWS FOR LASER AND PLASMA MACHINES

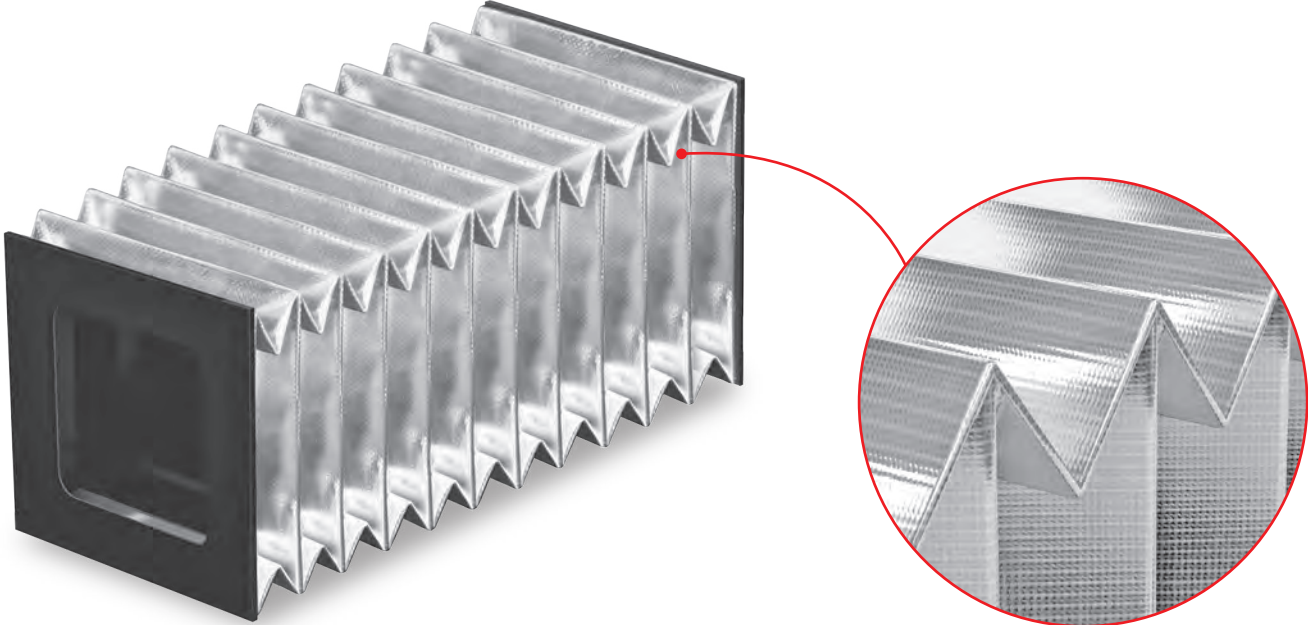
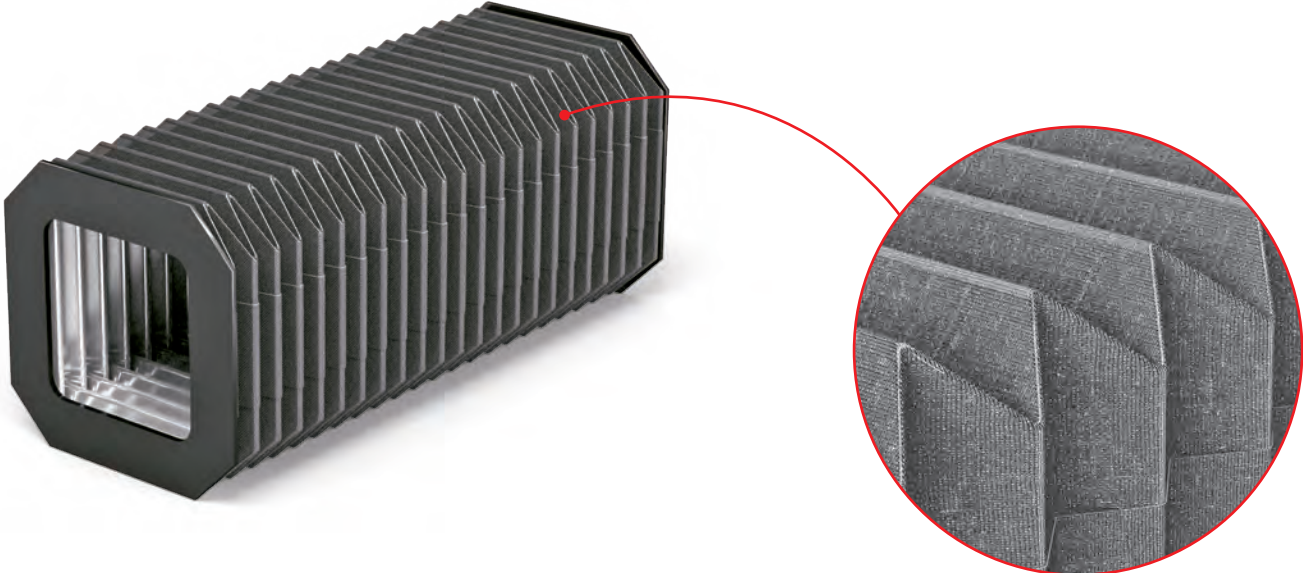
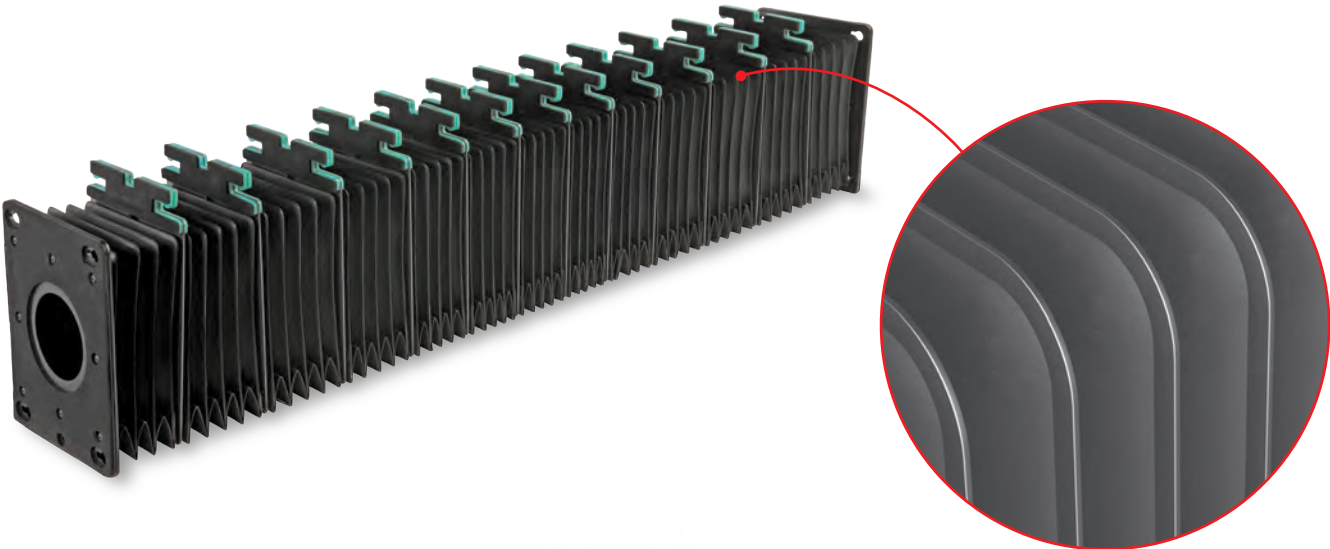

Reproduction of this page is strictly prohibited.

Thermic-Welded Covers Standard Systems for Linear Slides

Solution A: Fastening holdfast

Bellows-fastening standard systems for linear slides

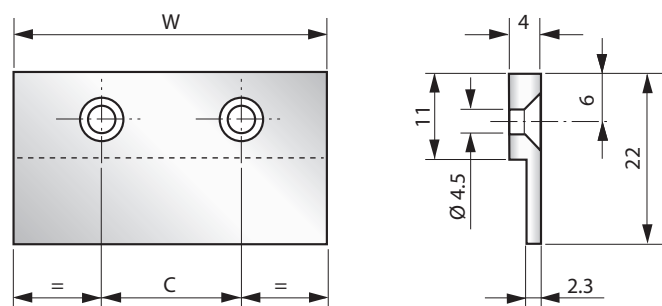
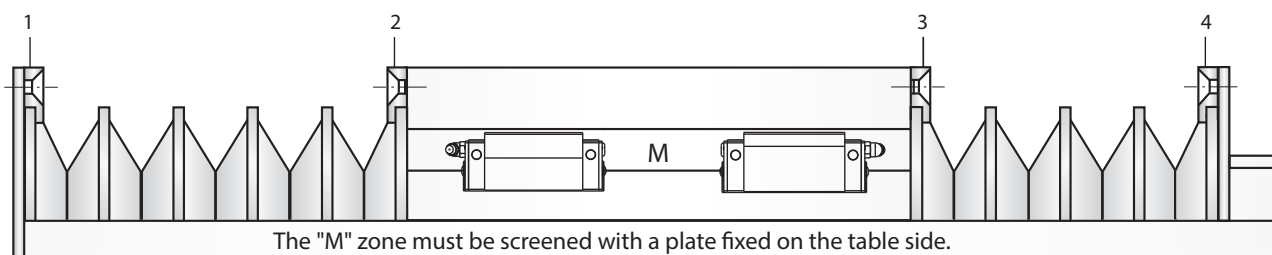

Suitable for bellows fastening in positions 1 - 2 - 3 - 4, with angular or plate supports provided by customers

SLIDE	W	C	N. HOLES
15	52	26	2
20	57	29	2
25	63	32	2
30	68	34	2
35	72	36	2
45	83	28	3
55	104	35	3
65	128	32	4

Solution B: Velcro flange fastening (B1 and B2)

Suitable for dry working places

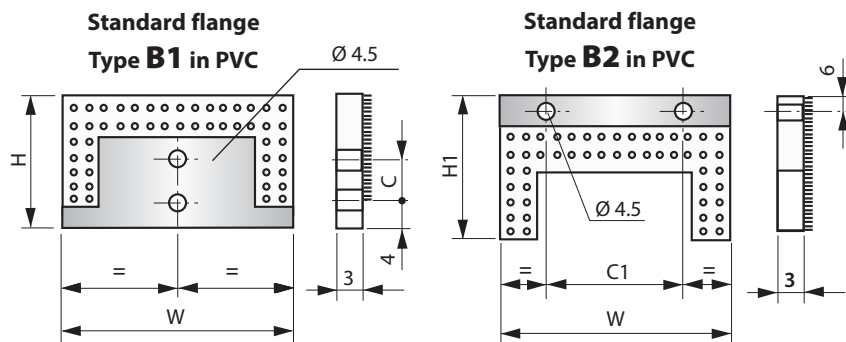
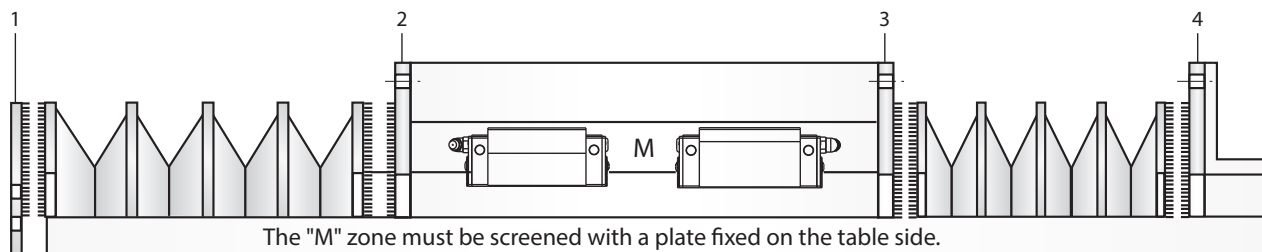

SLIDE	W	H	C	H1	C1	N. HOLES
15	56	36	0	42	26	2
20	61	40,5	8	46,5	29	2
25	67	43	8	46,5	32	2
30	72	51	8	54	34	2
35	76,5	51	18	53	36	2
45	87,5	61	18	62	28	3
55	108	73	18	69	35	3
65	132	90	18	86	32	4

- Pos.1 a) Fix the type 1 standard flange at the head of the slide.
b) Fix the bellows to the type 1 standard flange by pressing strongly.
- Pos.2-3 a) Fix the table or the mounting plate to the type 2 standard flange by means of screws.
b) Fix the bellows to the type 2 standard flange by pressing strongly.
- Pos.4 a) Fix the type 2 standard flange to the angular support provided by the customer by means of screws.
b) Fix the bellows to the type 2 standard flange by pressing strongly.

N.B. Fastening options showed in Pos. 1-4 are interchangeable

This technical card represents the standard systems used for the fastening of bellows for linear slides we can provide. For different sizes, please contact our technical department.



Thermic-Welded Covers for Linear Slides

Example of bellows mounted on linear slides

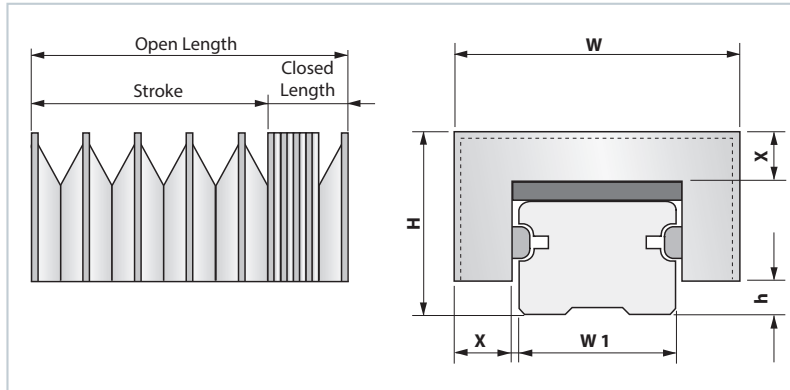

List of Standard Material

Type of material	Stiffener	Fabric material	Closed length for 1000 mm of open length
S1	PVC 0,50	PVC + Polyester + PVC 0,25 (TEMAT020)	90
P1	PVC 0,50	Polyurethane + Polyester + Polyurethane 0,25 (TEMAT015)	90
LX	PVC 1,00	Polyurethane Panox/Kevlar + Polyurethane 0,33 (TEMAT169)	150

Standard Thermic-Welded Covers Size

Slide nominal value	Ply height	Bellow width	Total height	Slide deviation
W1	X	W	H	h
15	19	56	36	5
20	19	61	40,5	5
25	19	67	43	7,5
30	19	72	51	8
35	19	76,5	51	9
45	19	87,5	61	10
55	25	108	73	15
65	32	132	90	15

Example of the identification code of a Thermic-Welded Cover for Linear Slides complete with flange

Slide manufacturer	THK
Slide model	HSR
Slide nominal value (W1)	35
Open length (stroke + closed length)	1500
Type of material	P1
Flange fixing system	A-A (See page 36)

NOTE: For the W1 slide over size 65, please contact our Technical Dept.

Questionnaire for Thermic-Welded Covers for Linear Slides

<p>! Slide Manufacturer</p> <p>Slide Model</p> <p>Slide Nominal Value (W1) <input type="checkbox"/> 15 <input type="checkbox"/> 20 <input type="checkbox"/> 25 <input type="checkbox"/> 30</p> <p> <input type="checkbox"/> 35 <input type="checkbox"/> 45 <input type="checkbox"/> 55 <input type="checkbox"/> 65</p> <p>Open length (Stroke + Closed length)mm</p> <p>Fabric type <input type="checkbox"/> S1 <input type="checkbox"/> P1 <input type="checkbox"/> LX</p> <p>Fastening system on guide top <input type="checkbox"/> Solution A with clamps</p> <p> <input type="checkbox"/> Solution B1 with flange in PVC</p> <p>Fastening system to table <input type="checkbox"/> Solution A with clamps</p> <p> <input type="checkbox"/> Solution B2 with flange in PVC</p>	<p>! Company name</p> <p>Phone:.....</p> <p>E-mail:.....</p> <p>Quantity:.....</p> <p>Annual demand:</p> <p>.....</p> <p>Date:.....</p> <p>Notes:.....</p> <p>.....</p> <p>.....</p>
--	---

NOTE: The data fields and/or tables marked by **!** are the least ones to be filled in order to give you a quotation. Please send an e-mail to info@pei.eu or a fax to +39 051 6464840.