

WAVE SKY Bellows for Overhead Protection for Portal Milling Machines

- **WAVE SKY** is a bellows that limits the escape of fumes, dust and chips from the workstation area.
WAVE SKY bellows reduces the suction force created during working: carbon fibres, composite materials and vaporised cooling lubricant.
 The special translucent fabric guarantees ample light in the work area.
 The motorised version makes for a quick opening and closing of the overhead apparatus.

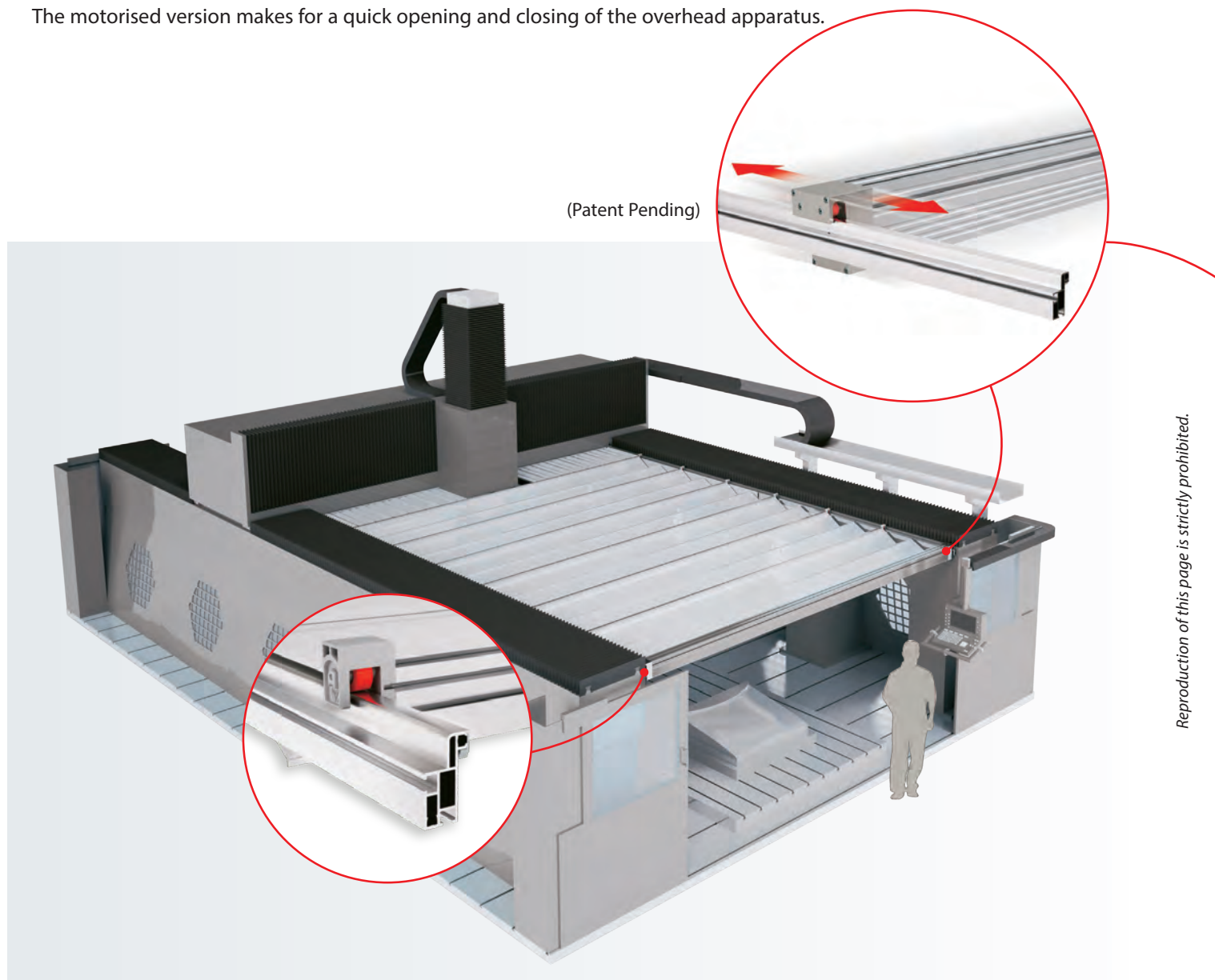

Reproduction of this page is strictly prohibited.

TECHNICAL SPECIFICATIONS

- ✓ **MAX SPEED:** 90 mt/min.
- ✓ **MAX ACCELERATION:** 1g
- ✓ **MAX WIDTH BETWEEN GUIDES:** 8.000 mm
- ✓ **MAXIMUM STROKE:** 25.000 mm
- ✓ **STANDARD FOLD HEIGHT:** 200 / 250 / 300 mm

EXAMPLE OF APPLICATION





WAVE SKY Bellows for Overhead Protection for Portal Milling Machines

- **FABRIC:** It shows excellent resistance to petroleum products, oils and heavy abrasion. The two-ply fabric insert gives an high transverse rigidity and a very attractive appearance. Normally used around large quantities of shavings. **TRANSLUCENT AND ANTISTATIC.**

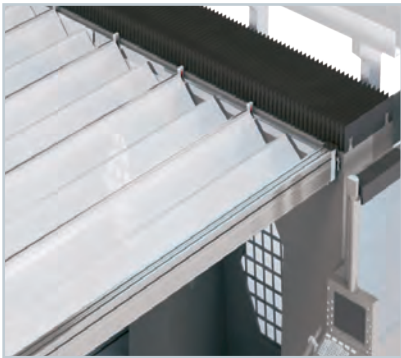

Special high strength fabric



Translucent

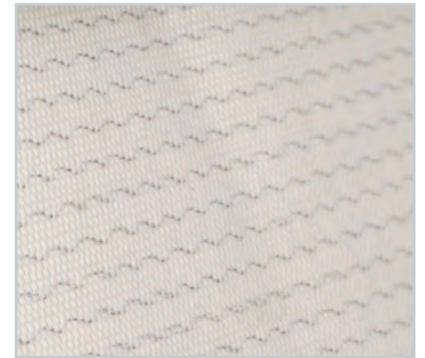

Antistatic

MOTORISATION: SMART DRIVE is the new motorised solution for **WAVE SKY** roof protection. Its aluminum extrusion profile is designed to obtain the best weight / resistance ratio.

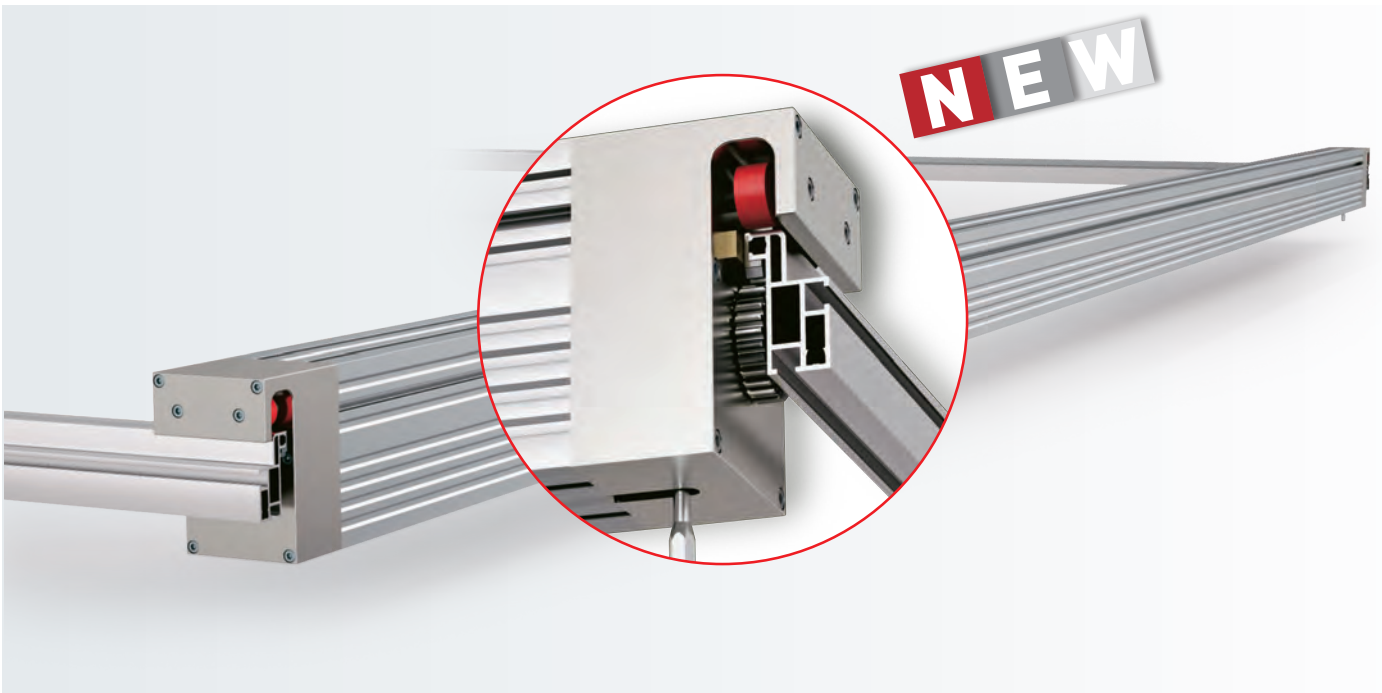

COMPONENTS

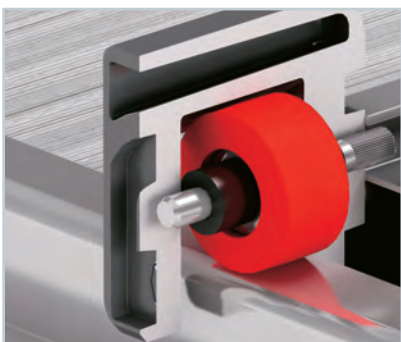

Movement using rollers

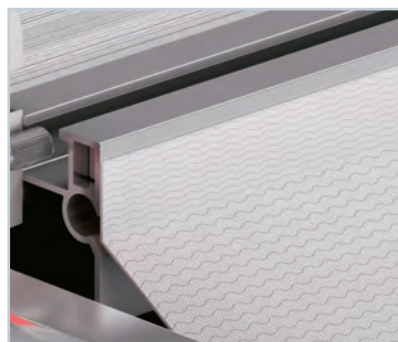

Modular support made of aluminium



Guide cover casing

Reproduction of this page is strictly prohibited.

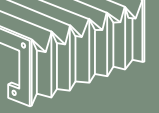

WAVE SKY LIGHT Overhead Protective Cover

- **WAVE SKY LIGHT** is a version of Wave Sky suitable for applications where despite long strokes a small closed length is required. Stability and durability are the same as for the traditional Wave Sky. The translucent fabric is suitable not only for machine tools, but also for other applications.



Reproduction of this page is strictly prohibited.

TECHNICAL SPECIFICATIONS

- ✓ **MAX SPEED:** 60 mt/min.
- ✓ **MAX ACCELERATION:** 1g
- ✓ **MAX WIDTH BETWEEN GUIDES:** 2.000 mm
- ✓ **MAXIMUM STROKE:** 8.000 mm
- ✓ **STANDARD FOLD HEIGHT:** 150 mm

EXAMPLE OF APPLICATION: for surface treatment tanks





WAVE SKY LIGHT Overhead Protective Cover

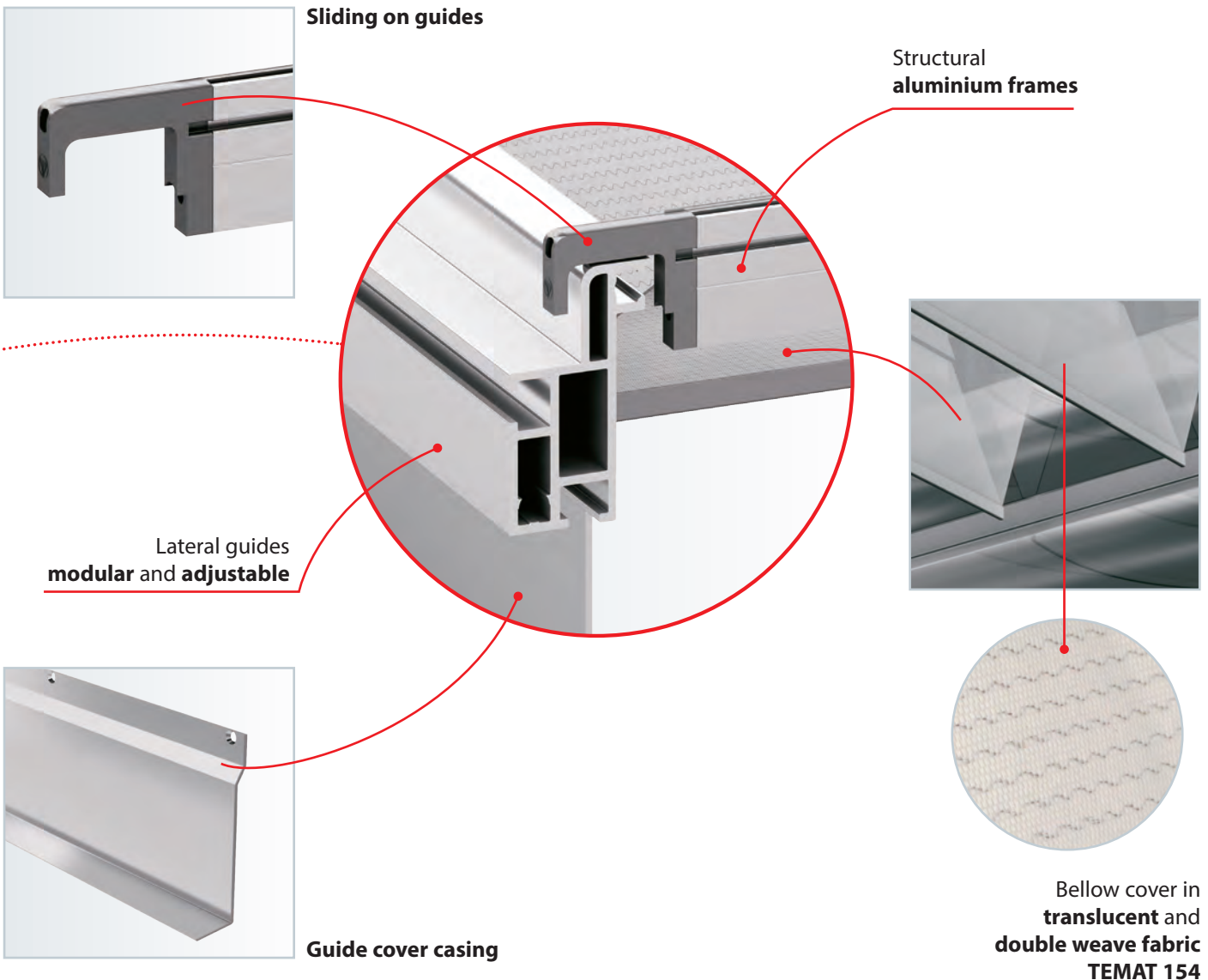

Reproduction of this page is strictly prohibited.

Code	Description of materials			Thickness	Heat resistance		Primary resistance characteristics
	Visible side	Fabric insert	Hidden side		Momentary contact °C	Continuous °C	
TEMAT154	Polyurethane	Polyester	Polyurethane	0,9	+130	-30 +90	Excellent resistance to petrol based products, oils and strong abrasion. The textile insert is made of a special fabric with high rigidity in the diagonal weave plus an aesthetically pleasing appearance. It is normally used in environments where there are large quantities of chips. TRANSLUCENT and ANTI-STATIC

MATERIALS FOR SPECIAL APPLICATIONS

Code	Description of materials			Thickness	Heat resistance		Primary resistance characteristics
	Visible side	Fabric insert	Hidden side		Momentary contact °C	Continuous °C	
TEMAT180	CPT**	Polyester	-	1,6	+1200	-25 +300	CERAMIX has an excellent abrasion resistance and excellent shear strength. CERAMIX shows excellent resistance to mineral oils and hot temperatures. The two-ply fabric insert gives a high transverse rigidity and a very attractive appearance. In WAVE-SKY only CERAMIX is used in the bellow folds close to the working area, when large quantities of ALUMINUM hot and shearing shavings are produced, in cases of high speed chip-removing dry work environments. ANTISTATIC-PROOF and SELF-EXTINGUISHING.
TEMAT181	CPT**	Polyester	-	0,9	+1200	-25 +300	CERAMIX LIGHT has an excellent abrasion resistance and excellent shear strength. The fabric insert is made by an ANTI-STATIC-PROOF material with good transverse rigidity and a very attractive appearance. CERAMIX LIGHT is normally used in case of hot and shearing shavings, or in high speed chip-removing dry or wet work environments. SELF-EXTINGUISHING FABRIC.

** Ceramic Polymer Technology