

Wing knobs

Technopolymer

MATERIAL

Glass-fibre reinforced polyamide based (PA) technopolymer, black colour, matte finish.

STANDARD EXECUTIONS

- **CT.476-B:** brass boss, threaded blind hole.
- **CT.476-FP:** brass boss, threaded pass-through hole.
- **CT.476-p:** zinc-plated steel threaded stud, chamfered flat end according to UNI 947 : ISO 4753 (see Technical data on page).
- **CT.476-SST-p:** AISI 303 stainless steel threaded stud, chamfered flat end according to UNI 947 : ISO 4753 (see Technical data on page).

FEATURES AND APPLICATIONS

These wing knobs allow high tightening torque values.



ELESA Original design

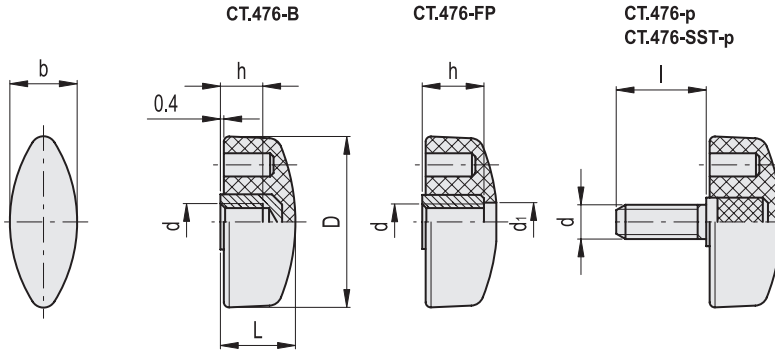

CT.476-B

Code	Description	D	d6H	L	b	h	C# [Nm]	⚖️
8252	CT.476/20 B-M4	20	M4	11	9,5	6	6	3
8302	CT.476/25 B-M5	26	M5	13	11	6	8	4
8307	CT.476/25 B-M6	26	M6	13	11	6	10	4
8321	CT.476/30 B-M5	32	M5	15	13	6	8	8
8351	CT.476/30 B-M6	32	M6	15	13	8	15	7
8356	CT.476/30 B-M8	32	M8	15	13	8	20	6
8432	CT.476/40 B-M5	40	M5	17	15,5	6	8	14
8433	CT.476/40 B-M6	40	M6	17	15,5	8	15	12
8452	CT.476/40 B-M8	40	M8	17	15,5	8	24	10
8502	CT.476/48 B-M8	48	M8	19	19	10	30	14
8552	CT.476/56 B-M10	56	M10	23	21	13	32	17

CT.476-FP

Code	Description	D	d6H	L	d1	b	h	C# [Nm]	⚖️
8326	CT.476/30 FP-M5	32	M5	15	6,5	13	12	9	8
8358	CT.476/30 FP-M6	32	M6	15	6,5	13	12	15	7
8436	CT.476/40 FP-M5	40	M5	17	9	15,5	12	9	13
8438	CT.476/40 FP-M6	40	M6	17	9	15,5	12	15	12
8458	CT.476/40 FP-M8	40	M8	17	9	15,5	14	22	10
8508	CT.476/48 FP-M8	48	M8	19	9	19	16	24	14
8558	CT.476/56 FP-M10	56	M10	23	11	21	20	30	18

"Max limit Tightening torque" means the max torque value at which the metal insert, in normal conditions of use, is perfectly and strongly anchored to the plastic material.

CT.476-p

Code	Description	D	d6g	L	l	b	C# [Nm]	⚖
8261	CT.476/20 p-M4x6	20	M4	11	6	9.5	6	4
8262	CT.476/20 p-M4x10	20	M4	11	10	9.5	6	4
8311	CT.476/25 p-M5x10	26	M5	13	10	11	8	6
8312	CT.476/25 p-M5x16	26	M5	13	16	11	8	7
8331	CT.476/30 p-M5x10	32	M5	15	10	13	8	7
8332	CT.476/30 p-M5x16	32	M5	15	16	13	8	9
8333	CT.476/30 p-M5x20	32	M5	15	20	13	8	13
8361	CT.476/30 p-M6x10	32	M6	15	10	13	14	8
8360	CT.476/30 p-M6x12	32	M6	15	12	13	14	9
8362	CT.476/30 p-M6x16	32	M6	15	16	13	14	10
8363	CT.476/30 p-M6x20	32	M6	15	20	13	14	11
8364	CT.476/30 p-M6x25	32	M6	15	25	13	14	12
8366	CT.476/30 p-M6x30	32	M6	15	30	13	14	13
8365	CT.476/30 p-M6x40	32	M6	15	40	13	14	14
8371	CT.476/30 p-M8x16	32	M8	15	16	13	16	13
8375	CT.476/30 p-M8x20	32	M8	15	20	13	16	14
8372	CT.476/30 p-M8x25	32	M8	15	25	13	16	16
8376	CT.476/30 p-M8x30	32	M8	15	30	13	16	18
8373	CT.476/30 p-M8x40	32	M8	15	40	13	16	20
8374	CT.476/30 p-M8x45	32	M8	15	45	13	16	24
8482	CT.476/40 p-M5x10	40	M5	17	10	15.5	8	11
8483	CT.476/40 p-M5x16	40	M5	17	16	15.5	8	12
8485	CT.476/40 p-M5x20	40	M5	17	20	15.5	8	13
8492	CT.476/40 p-M6x16	40	M6	17	16	15.5	14	13
8493	CT.476/40 p-M6x20	40	M6	17	20	15.5	14	14
8494	CT.476/40 p-M6x25	40	M6	17	25	15.5	14	16
8496	CT.476/40 p-M6x30	40	M6	17	30	15.5	14	17
8498	CT.476/40 p-M6x40	40	M6	17	40	15.5	14	19
8462	CT.476/40 p-M8x16	40	M8	17	16	15.5	18	15
8464	CT.476/40 p-M8x25	40	M8	17	25	15.5	18	16
8466	CT.476/40 p-M8x40	40	M8	17	40	15.5	18	22
8472	CT.476/40 p-M10x20	40	M10	17	20	15.5	28	25
8474	CT.476/40 p-M10x30	40	M10	17	30	15.5	28	27
8476	CT.476/40 p-M10x40	40	M10	17	40	15.5	28	31
8521	CT.476/48 p-M8x16	48	M8	19	16	19	20	18
8524	CT.476/48 p-M8x25	48	M8	19	25	19	20	21
8572	CT.476/56 p-M10x20	56	M10	23	20	21	40	35
8574	CT.476/56 p-M10x30	56	M10	23	30	21	40	39

CT.476-SST-p

STAINLESS STEEL

Code	Description	D	d6g	L	l	b	C# [Nm]	⚖
108261	CT.476/20-SST-p-M4x6	20	M4	11	6	9.5	6	4
108262	CT.476/20-SST-p-M4x10	20	M4	11	10	9.5	6	4
108311	CT.476/25-SST-p-M5x10	26	M5	13	10	11	8	6
108312	CT.476/25-SST-p-M5x16	26	M5	13	16	11	8	7
108313	CT.476/25-SST-p-M5x25	26	M5	13	25	11	8	8
108361	CT.476/30-SST-p-M6x10	32	M6	15	10	13	14	8
108362	CT.476/30-SST-p-M6x16	32	M6	15	16	13	14	10
108364	CT.476/30-SST-p-M6x20	32	M6	15	20	13	14	11
108366	CT.476/30-SST-p-M6x25	32	M6	15	25	13	14	12
108367	CT.476/30-SST-p-M6x30	32	M6	15	30	13	14	13
108372	CT.476/30-SST-p-M8x16	32	M8	15	16	13	16	13
108374	CT.476/30-SST-p-M8x20	32	M8	15	20	13	16	14
108375	CT.476/30-SST-p-M8x25	32	M8	15	25	13	16	16
108377	CT.476/30-SST-p-M8x30	32	M8	15	30	13	16	17
108378	CT.476/30-SST-p-M8x40	32	M8	15	40	13	16	20
108462	CT.476/40-SST-p-M8x16	40	M8	17	16	15.5	18	15
108464	CT.476/40-SST-p-M8x25	40	M8	17	25	15.5	18	16
108466	CT.476/40-SST-p-M8x40	40	M8	17	40	15.5	18	22
108521	CT.476/48-SST-p-M8x16	48	M8	19	16	19	20	18
108524	CT.476/48-SST-p-M8x25	48	M8	19	25	19	20	18
108572	CT.476/56-SST-p-M10x20	56	M10	23	20	21	40	35
108574	CT.476/56-SST-p-M10x30	56	M10	23	30	21	40	39

"Max limit Tightening torque" means the max torque value at which the metal insert, in normal conditions of use, is perfectly and strongly anchored to the plastic material.



Clamping knobs