

Bridge handles

Technopolymer

MATERIAL

Glass-fibre reinforced polyamide based (PA) technopolymer, grey-black colour, matte finish.

SCREW-COVERS

- ECA.B: glass-fibre reinforced polyamide based (PA) technopolymer, in Elecolors colours, matte finish, press-fit assembly. Supplied, removable by a screwdriver.

Available also as accessory sold separately (see table).

STANDARD EXECUTION

Pass-through assembly holes for cylindrical head screws with hexagon socket.

APPLICATIONS

EBR. handle can be assembled with: EBR-SW handles with electric switch, EBR-PN pneumatic valve, EBR-CH safety lock.

TECHNICAL DATA

Tensile stress and impact strength: the values F1, F2, L1 and L2 indicated in the table were obtained during breaking tests carried out with the appropriate dynamometric equipment under the test conditions shown in the figure with ambient temperature.

ACCESSORIES ON REQUEST

- ECA.B: glass-fibre reinforced polyamide based (PA) technopolymer screw-covers, in Elecolors colours, matte finish, press-fit assembly (see table).



ERGOSTYLE®

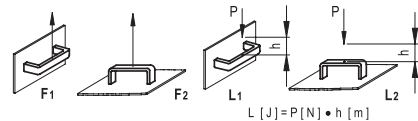

C1	C2	C3	C4	C5	C6	C17
RAL7021	RAL2004	RAL7035	RAL1021	RAL5024	RAL3000	RAL6017

ECA.B

Code	Description	Screw-cover for
29831-*	ECA.B1-*	EBR.150

* Complete with colour index (C1, ..., C17).

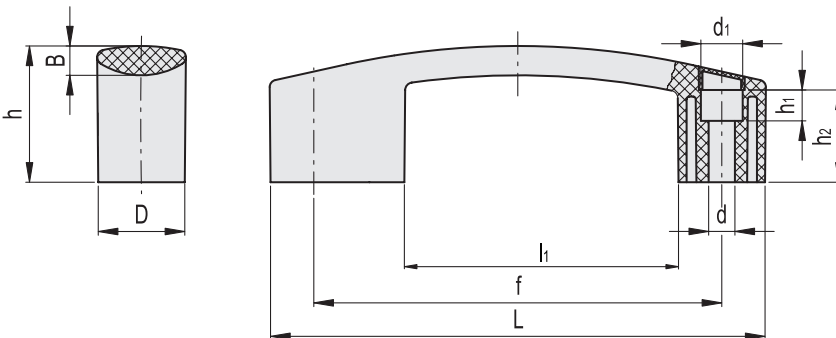

* Complete with colour index, example: 260511-C2 EBR.150-8-C2

C1	C2	C3	C4	C5	C6	C17
RAL7021	RAL2004	RAL7035	RAL1021	RAL5024	RAL3000	RAL6017

Code	Description	L	f	d	d1	D	h	h1	h2	B	l1	F1 [N]	F2 [N]	L1 [J]	L2 [J]	
260511-*	EBR.150-8-*	160	132±0.5	8.5	13.5	28	44	10	30	8.5	89	2800	2900	35	8	73