

Bi-directional flush pull handle

for screw mounting, technopolymer

MATERIAL

Glass-fibre reinforced polyamide based (PA) technopolymer, grey-black colour, matte finish.

STANDARD EXECUTION

Assembly by means of 4 zinc-plated steel self-tapping screws, Ø 3.5x20, supplied. Maximum tightening torque of the screws 1.2 [Nm].

FEATURES AND APPLICATIONS

ERB. bi-directional flush pull handles are suitable to open and close sliding doors.

The ergonomics of the cavity offers a safe and secure, comfortable and ergonomic grip. Rounded and compact lines.

TECHNICAL DATA

The lifting (F1) and pull out (F2) resistance values reported in the table are the result of the tests carried out in laboratory with handles assembled on strengthened metal sheet panels with thickness = 1.5 mm (strengthened for test purposes).

ASSEMBLY INSTRUCTIONS

1. Drill the handle housing according to the template dimensions.
2. Remove all drilling burrs before fitting the handle.
3. Fit the frontal body of the handle into the housing of the panel.
4. Fit the rear body of the handle onto the rear panel and press until the complete fitting with the frontal handle part.
5. Fit the two bodies with self-tapping screws.



ERGOSTYLE®

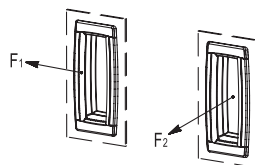

Drilling template
(remove all drilling burrs before fitting the handle)

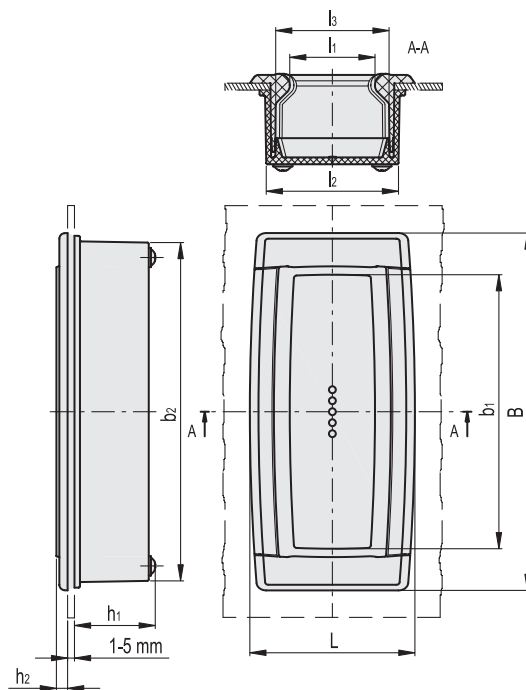
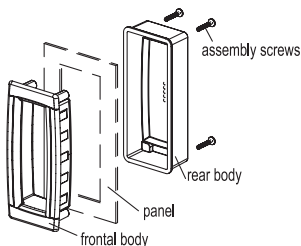
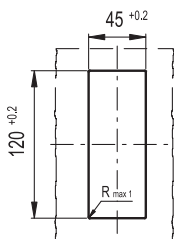

Code	Description	B	L	h1	h2	b1	b2	l1	l2	l3	F1 [N]	F2 [N]	⚖️
261511-C1	ERB.130-C1	130	60	29.5	3	101	123	31	48	41	3500	3500	95