

Adjustable handles

Metal Detectable technopolymer, stainless steel clamping element

LEVER BODY

Glass-fibre reinforced polyamide based (PA) technopolymer, RAL 5001 blue colour, matte finish.

Produced from FDA compliant raw material (FDA CFR.21 and EU 10/2011).

The special technopolymer contains additives detectable by means of metal detectors.

Built-in zinc alloy toothed insert for coupling to the metal clamping element.

STANDARD EXECUTIONS

- **ERZ-SST-MD**: AISI 303 stainless steel clamping element with threaded hole and retaining screw. AISI 302 stainless steel return spring.

- **ERZ-SST-p-MD**: AISI 303 stainless steel clamping element with threaded stud and retaining screw. AISI 302 stainless steel return spring.

Retaining screw with six-lobed socket to fit TORX®*.

FEATURES AND APPLICATIONS

The RAL 5001 blue colour is easily visible in case of accidental food contamination. Furthermore the material additives are metal detectable at a cubic particle size of 5mm per side.

In order to improve the detection, the metal detector calibration must take into account the food/substance type at risk of contamination considering the moisture contained in it.

Particularly suitable for applications in the food and pharmaceutical industries.

Particularly suitable when the lever turning angle is limited owing to lack of space.

The metal teeth of the built-in zinc alloy insert allow the assembly of clamping elements completely made out of metal, which can be easily modified by machining in case of special assembly requirements.



ERGOSTYLE®

INSTRUCTIONS OF USE

For clamping, lift the lever to disengage the clamping device teeth and bring it back to start position. By releasing the lever, the return spring automatically engages the teeth.

If the lever cannot make a 360° rotation, the clamping element can be easily screwed by means of the six-lobed socket front head screw (after having disengaged the lever).

* Registered trademark by TEXTRON INC.

ERZ-SST-MD

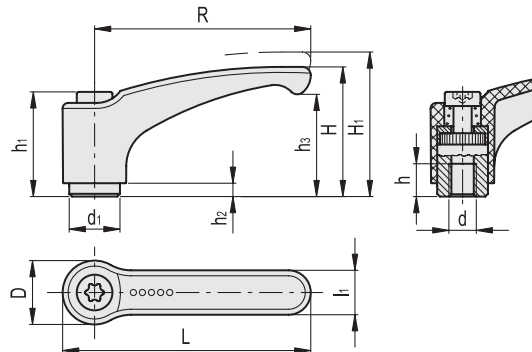

ERZ-SST-MD

STAINLESS STEEL

Code	Description	R	d	L	D	H	H ₁	h	h ₁	h ₂	h ₃	d ₁	l _i	Teeth no.	⚖️
198105	ERZ.44-SST-M5-MD	44	M5	52	16	30.5	34	8	24.5	3.5	22.5	10	11	18	16
198135	ERZ.63 SST-M6-MD	63	M6	72.5	19	38.5	42	10	31	3.5	30	13.5	13.5	24	36
198155	ERZ.78 SST-M8-MD	79	M8	91.5	24.5	45	50.5	14	36	3.5	35	16	16	26	61
198175	ERZ.95-SST-M10-MD	95	M10	108	26	56.5	61.5	17	43	5	45	19	18	28	93

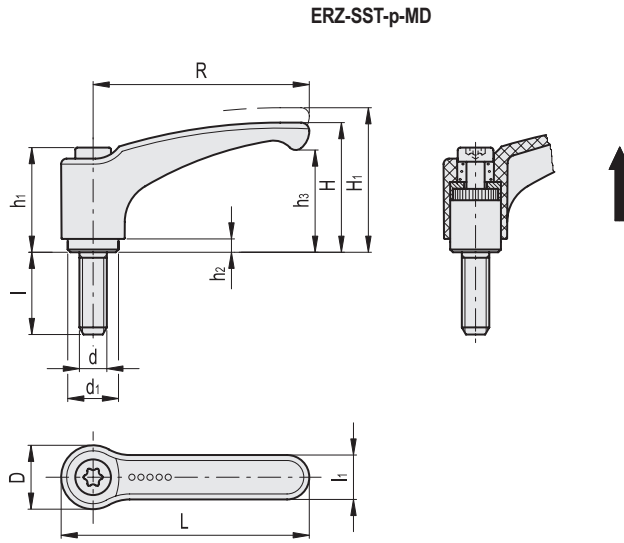

ERZ-SST-p-MD

STAINLESS STEEL

Code	Description	R	d	L	D	H	H1	h1	h2	h3	d1	l	l1	Teeth no.	
198233	ERZ.44-SST-p-M5x12-MD	44	M5	52	16	30.5	34	24.5	3.5	22.5	10	12	11	18	17
198235	ERZ.44-SST-p-M5x16-MD	44	M5	52	16	30.5	34	24.5	3.5	22.5	10	16	11	18	18
198237	ERZ.44-SST-p-M5x20-MD	44	M5	52	16	30.5	34	24.5	3.5	22.5	10	20	11	18	19
198239	ERZ.44-SST-p-M5x25-MD	44	M5	52	16	30.5	34	24.5	3.5	22.5	10	25	11	18	20
198241	ERZ.44-SST-p-M5x32-MD	44	M5	52	16	30.5	34	24.5	3.5	22.5	10	32	11	18	21
198429	ERZ.63-SST-p-M6x16-MD	63	M6	72.5	19	38.5	42	31	3.5	30	13.5	16	13.5	24	40
198431	ERZ.63-SST-p-M6x20-MD	63	M6	72.5	19	38.5	42	31	3.5	30	13.5	20	13.5	24	41
198433	ERZ.63-SST-p-M6x25-MD	63	M6	72.5	19	38.5	42	31	3.5	30	13.5	25	13.5	24	42
198435	ERZ.63-SST-p-M6x32-MD	63	M6	72.5	19	38.5	42	31	3.5	30	13.5	32	13.5	24	43
198437	ERZ.63-SST-p-M6x40-MD	63	M6	72.5	19	38.5	42	31	3.5	30	13.5	40	13.5	24	44
198439	ERZ.63-SST-p-M6x50-MD	63	M6	72.5	19	38.5	42	31	3.5	30	13.5	50	13.5	24	46
198673	ERZ.78-SST-p-M8x20-MD	79	M8	91.5	24.5	45	50.5	36	3.5	35	16	20	16	26	69
198675	ERZ.78-SST-p-M8x25-MD	79	M8	91.5	24.5	45	50.5	36	3.5	35	16	25	16	26	72
198677	ERZ.78-SST-p-M8x32-MD	79	M8	91.5	24.5	45	50.5	36	3.5	35	16	32	16	26	76
198679	ERZ.78-SST-p-M8x40-MD	79	M8	91.5	24.5	45	50.5	36	3.5	35	16	40	16	26	80
198681	ERZ.78-SST-p-M8x50-MD	79	M8	91.5	24.5	45	50.5	36	3.5	35	16	50	16	26	84
198683	ERZ.78-SST-p-M8x63-MD	79	M8	91.5	24.5	45	50.5	36	3.5	35	16	63	16	26	89
198823	ERZ.95-SST-p-M10x20-MD	95	M10	108	26	56.5	61.5	43	5	45	19	20	18	28	113
198825	ERZ.95-SST-p-M10x25-MD	95	M10	108	26	56.5	61.5	43	5	45	19	25	18	28	115
198827	ERZ.95-SST-p-M10x32-MD	95	M10	108	26	56.5	61.5	43	5	45	19	32	18	28	118
198829	ERZ.95-SST-p-M10x40-MD	95	M10	108	26	56.5	61.5	43	5	45	19	40	18	28	121
198831	ERZ.95-SST-p-M10x50-MD	95	M10	108	26	56.5	61.5	43	5	45	19	50	18	28	128
198833	ERZ.95-SST-p-M10x63-MD	95	M10	108	26	56.5	61.5	43	5	45	19	63	18	28	133



3
Clamping levers