

## Door lock handles

with or without built-in lock, technopolymer

### HANDLE

Glass-fibre reinforced polyamide based (PA) technopolymer, black colour, matte finish. Acetal resin based (POM) technopolymer retention wings.

### STATOR AND ROTOR

Nickel-plated zinc alloy.

### CLOSING LEVER

Zinc-plated steel, 2 mm thickness.

### TWO KEYS

Nickel-plated brass.

### STANDARD EXECUTIONS

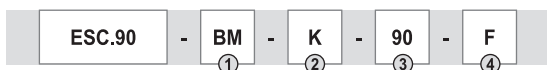

① **BM:** back mounting.  
**FM:** front mounting.

② **K:** with lock.  
**SS:** without lock.

#### Only for K execution

③ **90:** lock with key (100 combinations) removable in the closing position, rotation by 90°.

**180:** lock with key (200 combinations) removable in two positions at 180°, rotation by 180°.

④ **F:** different combination.

**U:** same combination (all locks can be opened with the same key).

Order example with lock:  
**225023 ESC.90-BM-K-90-F**  
Order example without lock:  
**225021 ESC.90-BM-SS**

### FEATURES AND APPLICATIONS

- ESC door lock handle (ELESA patent) keeps the door locked in the closed position. Because of its location outside the door, its installation is very simple.
- The handle dimensions are such as to allow the assembly on profiles with a minimum size of 25 mm and a maximum of 40 mm.
- The handle is able to compensate for any misalignment of the door bringing it back to the correct position while closing by means of the built-in guides.
- The handle is tamperproof from the outside thanks to the rear fastening (ESC.90-BM) or front fastening (ESC.90-FM) with caps not removable when the handle is closed and preventing access to the screws.
- Under specific tests the handle has always maintained unchanged performance for over 40000 cycles.



ERGOSTYLE®

### Application example

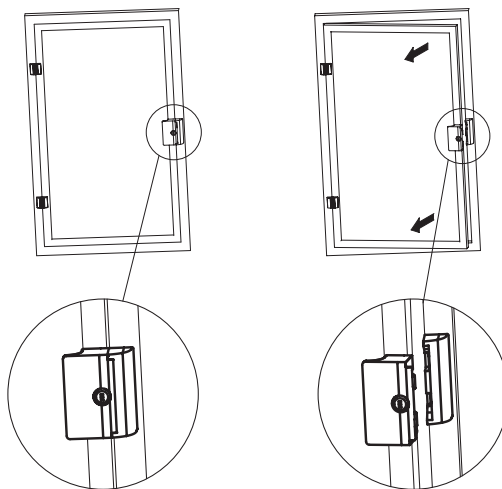

**ASSEMBLY INSTRUCTIONS**

To ensure a correct opening release strength (45 N as long as the handle is assembled in best conditions), we recommend to position the two elements of the handle as close as possible (Fig. 1) during assembly.

Rear mounting by means of M6 hexagonal-head screws DIN 933 or M6 hexagonal nuts DIN 439B: place the screw as shown in Fig. 2. For ease of assembly with the nut, we recommend initially to fasten the nut as shown in the drawing.

Front mounting by means of M6 cylindrical-head screws: place the doorframe and the door by applying the relevant caps that prevent access to the screws (Fig. 3) (tamperproof).

Suggested tightening torque: 5 Nm.

Only when the door is open, it is possible to remove the caps with a screwdriver on both the door (Fig. 4) and the doorframe (Fig. 5).

Fig.1

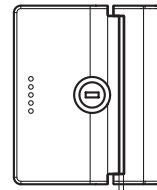

Reduce this distance to the min.

Fig.2  
Back mounting (ESC.90-BM)

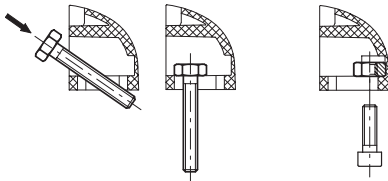

Fig.3  
Front mounting (ESC.90-FM)

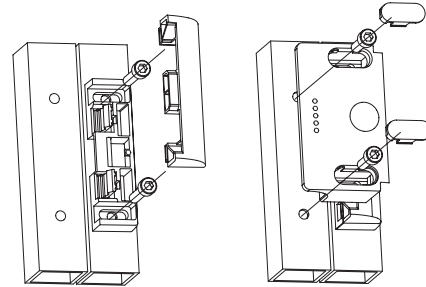

Fig.4  
(ESC.90-FM)

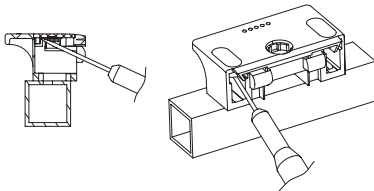
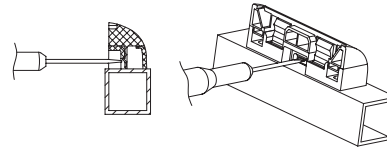
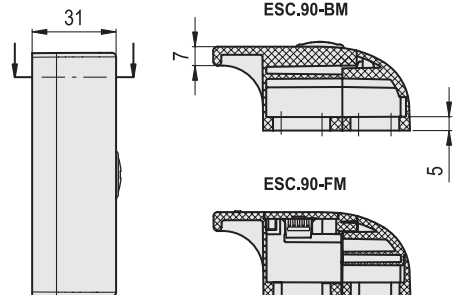
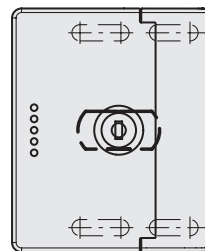
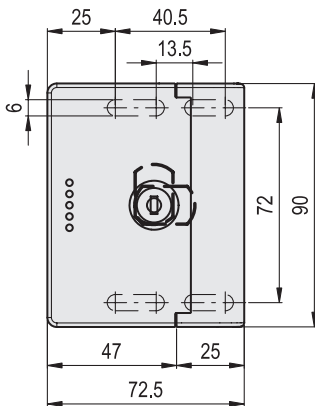

Fig.5  
(ESC.90-FM)



ESC.90.....90

ESC.90.....180



Code	Description	⚖
225021	ESC.90-BM-SS	83
225023	ESC.90-BM-K-90-F	115
225025	ESC.90-BM-K-180-F	115
225029	ESC.90-BM-K-90-U	115
225031	ESC.90-BM-K-180-U	115

Code	Description	⚖
225022	ESC.90-FM-SS	83
225024	ESC.90-FM-K-90-F	115
225026	ESC.90-FM-K-180-F	115
225030	ESC.90-FM-K-90-U	115
225032	ESC.90-FM-K-180-U	115

