

Level indicators with thermometer and protection frame

Transparent technopolymer and zinc alloy, for use with fluids containing alcohol, high UV resistance

BODY

Transparent polyamide based (PA-T/AR) technopolymer. Highly resistant to shocks, solvents, oils with additives, aliphatic and aromatic hydrocarbons, petrol, naphtha, phosphoric esters, additives and detergents containing alcohol. High UV resistance.

PROTECTION FRAME

Zinc-alloy, sandblasted and treated finish.

SCREWS, NUTS AND WASHERS

Zinc-plated steel.

PACKING RINGS

Step-shaped for the seal on the reservoir walls and NBR synthetic rubber O-ring screw underhead. Suggested roughness of the packing ring application surface $Ra = 3 \mu m$.

CONTRAST SCREEN

White lacquered aluminium. The housing, in the appropriate external rear slot, guarantees the best protection from direct contact with fluid.

It can be taken out from the inclined side, before assembly to allow the insertion of level lines or words.

THERMOMETER

Incorporated thermometer for temperature reading.

MAXIMUM CONTINUOUS WORKING TEMPERATURE

90°C (with oil).

FEATURES AND PERFORMANCES

Ultrasound welding to guarantee a perfect seal.

Lens effect for a better visibility of the fluid level and temperature.

Special openings in the protection frame provide maximum fluid level visibility even from side positions.

All shocks are absorbed by the frame that transmits them directly onto the wall of the reservoir.

TECHNICAL DATA

In laboratory tests carried out with mineral oil type CB68 (according to ISO 3498) at 23°C for a limited period of time, the weld stood up to 13 bar.

For use with other fluids and under different pressure and temperature conditions, please contact ELESA Technical Department.

In any case we suggest to verify the suitability of the product under the actual working conditions.

SPECIAL EXECUTIONS ON REQUEST

- Indicators with cylindrical or step-shaped (NBR or FKM) packing rings (instead of OR) for mounting on reservoirs having rough surfaces or in any case not perfectly flat.

ACCESSORIES ON REQUEST

When fitting is not possible from the inside of the reservoir and the walls are not thick enough, the screws can be used together with Fast Mounting Kit (see page -)



ELESA Original design

Drilling template

Holes without burrs and chamfer

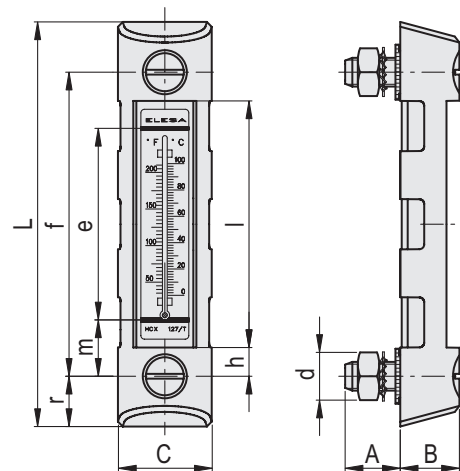
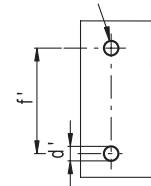

Code	Description	f	d	A	B	C	L	e	h	l	m	r	d'±0.2	f'±0.2	C# [Nm]	
11376-R	HCX.127/T-AR-P-M12	127	M12	22	25	39	169	80	12	103	23	21	12.5	127	12	281

Maximum tightening torque.