

Level indicators with thermometer and protection frame

SUPER-Technopolymer and transparent technopolymer, for use with fluids containing alcohol, high UV resistance

BODY

Transparent polyamide based (PA-T/AR) technopolymer. Highly resistant to shocks, solvents, oils with additives, aliphatic and aromatic hydrocarbons, petrol, naphtha, phosphoric esters, additives and detergents containing alcohol. High UV resistance.

PROTECTION FRAME

Glass-fibre reinforced polyamide based (PA) SUPER-technopolymer, black colour, matte finish. Supplied assembled, removable by a screwdriver.

PACKING RINGS

- NBR: synthetic rubber O-Ring.
- FKM: FKM type VITON®*O-Ring.

Suggested roughness of the packing ring application surface Ra = 3 µm.

* Registered trademark by DuPont Dow Elastomers.

CONTRAST SCREEN

White lacquered aluminium. The housing, in the appropriate external rear slot, guarantees the best protection from direct contact with fluid.

It can be taken out from the inclined side, before assembly to allow the insertion of level lines or words.

THERMOMETER

Incorporated thermometer for temperature reading.

STANDARD EXECUTIONS

- **HCX/T-AR-PT**: zinc-plated steel screws, nuts and washers, NBR packing ring.
- **HCX/T-AR-PT-SST**: AISI 303 stainless steel screws, AISI 304 stainless steel nuts and washers, FKM packing ring.
- **HCX/T-AR-PT-VT**: glass-fibre reinforced polyamide based (PA) SUPER-technopolymer screws, AISI 304 stainless steel nuts and washers, FKM packing ring.

MAXIMUM CONTINUOUS WORKING TEMPERATURE

90°C (with oil).

FEATURES AND PERFORMANCES

Ultrasound welding to guarantee a perfect seal.

Lens effect for a better visibility of the fluid level and temperature.

Special openings in the protection frame provide maximum fluid level visibility even from side positions.

All shocks are absorbed by the frame that transmits them directly onto the wall of the reservoir.

Thanks to the SUPER-technopolymer screws, HCX/T-AR-PT-VT column level indicator can be used in corrosion resistance applications where stainless steel is not necessary.

The special slotted head of the SUPER-technopolymer screws is especially designed to reach an optimum tightening of the packing rings by applying an adequate tightening torque (ELESA patent) thus avoiding unnecessary stress to the screws.



ELESA Original design

TECHNICAL DATA

In laboratory tests carried out with mineral oil type CB68 (according to ISO 3498) at 23°C for a limited period of time, the weld stood up to: 13 bar (HCX.76-PT-AR and HCX.127-PT-AR) 10 bar (HCX.254-PT-AR).

Considering the SUPER-technopolymer screws, the maximum working pressure cannot be higher than 5 bar at 20°C and 2 bar at 90°C.

For use with other fluids and under different pressure and temperature conditions, please contact ELESA Technical Department.

In any case we suggest to verify the suitability of the product under the actual working conditions.

SPECIAL EXECUTIONS ON REQUEST

- Indicators with cylindrical or step-shaped (NBR or FKM) packing rings (instead of OR) for mounting on reservoirs having rough surfaces or in any case not perfectly flat.

ACCESSORIES ON REQUEST

When fitting is not possible from the inside of the reservoir and the walls are not thick enough, the screws can be used together with Fast Mounting Kit (see page -)

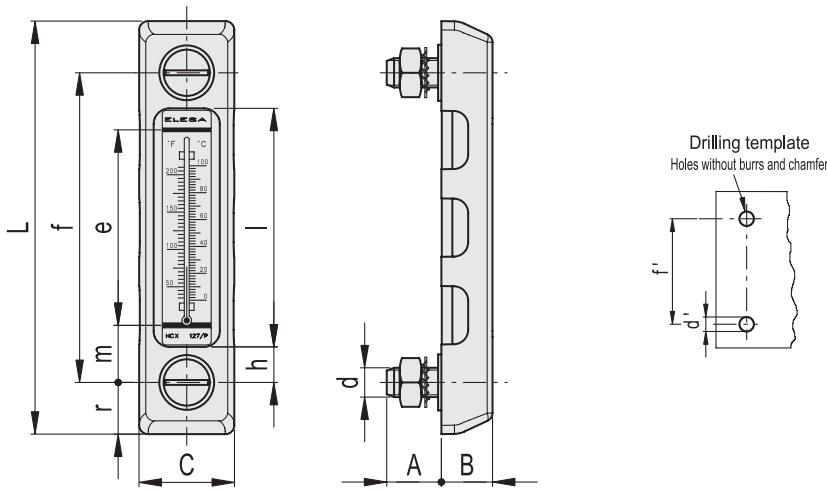

HCX/T-AR-PT

Code	Description	f	d	A	B	C	L	e	h	l	m	r	d'-0.2 f±0.2	Thermo- meter scale°C	Thermo- meter scale°F	C#		
11336-R	HCX.76/T-AR-PT-M10	76	M10	20	19	35.5	115	40	13.5	49	18	19.5	10.5	76	20+100	68÷210	12	117
11377-R	HCX.127/T-AR-PT-M12	127	M12	22	21	39	169	80	15	96	23	21	12.5	127	0+100	32÷210	12	191
11369-R	HCX.254/T-AR-PT-M12	254	M12	21	21.5	44.5	301	203	18	218	26	23.5	12.5	254	0+100	32÷210	10	288

HCX/T-AR-PT-SST

STAINLESS STEEL

Code	Description	f	d	A	B	C	L	e	h	l	m	r	d'-0.2 f±0.2	Thermo- meter scale°C	Thermo- meter scale°F	C#		
11338-R	HCX.76/T-AR-PT-SST-M10	76	M10	20	19	35.5	115	40	13.5	49	18	19.5	10.5	76	20+100	68÷210	12	119
11378-R	HCX.127/T-AR-PT-SST-M12	127	M12	22	21	39	169	80	15	96	23	21	12.5	127	0+100	32÷210	12	193
11370-R	HCX.254/T-AR-PT-SST-M12	254	M12	21	21.5	44.5	301	203	18	218	26	23.5	12.5	254	0+100	32÷210	10	290

HCX/T-AR-PT-VT

Code	Description	f	d	A	B	C	L	e	h	l	m	r	d'-0.2 f±0.2	Thermo- meter scale°C	Thermo- meter scale°F	C#		
111362-R	HCX.76/T-AR-PT-VT-M10	76	M10	23	19	35.5	115	40	13.5	49	18	19.5	10.5	76	20+100	68÷210	4	105
111364-R	HCX.127/T-AR-PT-VT-M10	127	M10	22	21	39	169	80	15	96	23	21	10.5	127	0+100	32÷210	4	174
111363-R	HCX.127/T-AR-PT-VT-M12	127	M12	22	21	39	169	80	15	96	23	21	12.5	127	0+100	32÷210	6	147
111379-R	HCX.254/T-AR-PT-VT-M12	254	M12	21	21.5	44.5	301	203	18	218	26	23.5	12.5	254	0+100	32÷210	6	248

Maximum tightening torque.

