

Levelling feet for ground mounting

ESD conductive technopolymer base, steel stem

BASE

Glass-fibre reinforced polyamide based (PA) special conductive technopolymer, black colour, matte finish.

Surface resistivity = $10^3 \Omega$ (ASTM D257 measuring method).

Volume resistivity = $10^3 \Omega\text{cm}$ (ASTM D257 measuring method).

ARTICULATED STEM

Threaded zinc-plated steel with regulation hexagon.

STANDARD EXECUTIONS

- **LV.F-ESD-C**: without no-slip disk.

- **LV.F-AS-ESD-C**: with NBR rubber no-slip disk, hardness 70 Shore A, supplied assembled to the base.

Surface resistivity = $10^3 \Omega$ (ASTM D991 measuring method).

Volume resistivity = $10^3 \Omega\text{cm}$ (ASTM D991 measuring method).

GROUND MOUNTING

By means of two holes at 180°, supplied covered by a diaphragm (which can be easily removed by a metal tool), to avoid all unhealthy deposits of dirt and dust when the ground mounting is not required (see Fig.1).

FEATURES AND APPLICATIONS

The special conductive technopolymer (ESD-C Electrostatic Discharge Conductive) prevents the accumulation of electrostatic charge.

The particular assembling system of the no-slip disk to the base assures a perfect anchoring, preventing separation even in case of impact during transport or of adhesion (sticking) to the floor (see No-slip disks on page -).

The special knurling under the lower lip of the base provides excellent stability and grip when using the levelling element without no-slip disk even on surfaces that are not perfectly flat.

The bases are suitable for "ESD PROTECTED AREA" (EPA) where components, which are susceptible to electrostatic discharges, are handled. The (ESD-C) indelibly printed mark on the surface of the levelling feet bases identifies the particular conductive features of the material according to EN 100015/1 and IEC 61340-5-1.

ORDER INFORMATION

The levelling feet are supplied unassembled to make carriage and storage easier. The components (base and stem) are supplied in separate packing: less volume taken and better protection from scratches and dirt.

To order bases and stems separately, see:

- table of possible combinations Bases/Stems (see page -)
- the codes of the Bases (see page -)
- the codes of the Stems (see page -).

ACCESSORIES ON REQUEST

Zinc-plated steel nut (see Nuts NT. on page -).



ELESA Original design

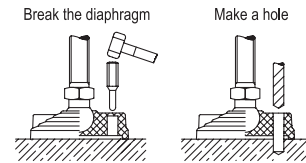
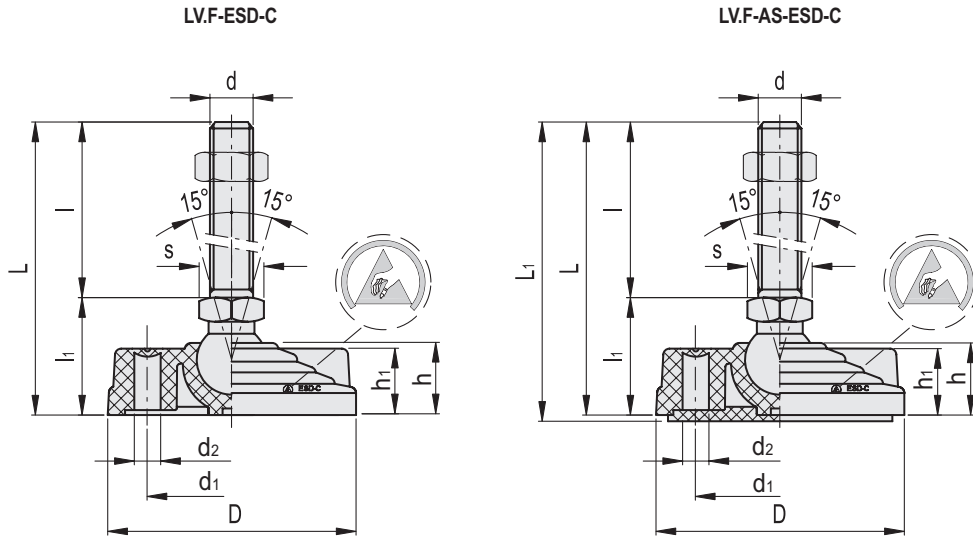

Fig.1



LV.F-ESD-C

Code	Description	D	d	d ₁	L	l	l ₁	d ₂	h	h ₁	s	Articulation ∅	Max. limit static load* [N]	⚖️
312451-ESD	LV.F-100-14-M8x43-ESD-C	100	M8	70	76	43	33	12.5	24	23	14	14	18000	132
312453-ESD	LV.F-100-14-M8x68-ESD-C	100	M8	70	101	68	33	12.5	24	23	14	14	18000	139
312461-ESD	LV.F-100-14-M10x43-ESD-C	100	M10	70	76	43	33	12.5	24	23	14	14	18000	139
312463-ESD	LV.F-100-14-M10x68-ESD-C	100	M10	70	101	68	33	12.5	24	23	14	14	18000	151
312465-ESD	LV.F-100-14-M10x98-ESD-C	100	M10	70	131	98	33	12.5	24	23	14	14	18000	166
312471-ESD	LV.F-100-14-M12x43-ESD-C	100	M12	70	76	43	33	12.5	24	23	14	14	18000	148
312473-ESD	LV.F-100-14-M12x68-ESD-C	100	M12	70	101	68	33	12.5	24	23	14	14	18000	165
312475-ESD	LV.F-100-14-M12x98-ESD-C	100	M12	70	131	98	33	12.5	24	23	14	14	18000	186
312481-ESD	LV.F-100-14-M16x68-ESD-C	100	M16	70	101	68	33	12.5	24	23	16	14	18000	205
312483-ESD	LV.F-100-14-M16x108-ESD-C	100	M16	70	141	108	33	12.5	24	23	16	14	18000	258
312485-ESD	LV.F-100-14-M16x148-ESD-C	100	M16	70	181	148	33	12.5	24	23	16	14	18000	312
312487-ESD	LV.F-100-14-M16x168-ESD-C	100	M16	70	201	168	33	12.5	24	23	16	14	18000	336

LV.F-AS-ESD-C

Code	Description	D	d	d ₁	L	L ₁	l	l ₁	d ₂	h	h ₁	s	Articulation on r∅	Max. limit static load* [N]	⚖️
315451-ESD	LV.F-100-14-AS-M8x43-ESD-C	100	M8	70	76	79	43	33	12.5	24	23	14	14	18000	175
315453-ESD	LV.F-100-14-AS-M8x68-ESD-C	100	M8	70	101	104	68	33	12.5	24	23	14	14	18000	182
315461-ESD	LV.F-100-14-AS-M10x43-ESD-C	100	M10	70	76	79	43	33	12.5	24	23	14	14	18000	182
315463-ESD	LV.F-100-14-AS-M10x68-ESD-C	100	M10	70	101	104	68	33	12.5	24	23	14	14	18000	194
315465-ESD	LV.F-100-14-AS-M10x98-ESD-C	100	M10	70	131	134	98	33	12.5	24	23	14	14	18000	209
315471-ESD	LV.F-100-14-AS-M12x43-ESD-C	100	M12	70	76	79	43	33	12.5	24	23	14	14	18000	191
315473-ESD	LV.F-100-14-AS-M12x68-ESD-C	100	M12	70	101	104	68	33	12.5	24	23	14	14	18000	208
315475-ESD	LV.F-100-14-AS-M12x98-ESD-C	100	M12	70	131	134	98	33	12.5	24	23	14	14	18000	229
315481-ESD	LV.F-100-14-AS-M16x68-ESD-C	100	M16	70	101	104	68	33	12.5	24	23	16	14	18000	248
315483-ESD	LV.F-100-14-AS-M16x108-ESD-C	100	M16	70	141	144	108	33	12.5	24	23	16	14	18000	301
315485-ESD	LV.F-100-14-AS-M16x148-ESD-C	100	M16	70	181	184	148	33	12.5	24	23	16	14	18000	355
315487-ESD	LV.F-100-14-AS-M16x168-ESD-C	100	M16	70	201	204	168	33	12.5	24	23	16	14	18000	379

* The max static load is the value above which the load applied to the element may cause some plastic material breakage, in particular conditions of use. Obviously, a factor that takes into consideration the importance and the safety level of the specific application must be applied to this value.

