

Tubular handles

Technopolymer

TUBE

Aluminium, coating in white colour similar to RAL 9002, handle shanks and end caps in white colour similar to RAL 9002.

HANDLE SHANKS

Glass-fibre reinforced polyamide based (PA) technopolymer, matte finish.

TUBE END CAPS

Polyamide based (PA) technopolymer.

COLOUR

White similar to RAL 9002.

STANDARD EXECUTION

Special zinc-plated steel screws with threaded blind holes, fitted to the tube by means of brass nuts.

FEATURES AND APPLICATIONS

This handle, thanks to its white colour and glossy finish, is particularly suitable for applications on medical and hospital equipment and on food processing machines whose parts, for hygienic reasons, must be frequently cleaned.

Its solid shape without cavities prevents unhealthy residues from depositing.

TECHNICAL DATA

Tensile stress: F2 values reported in the table are the result of breaking tests carried out with the appropriate dynamometric equipment under the test conditions shown in the figure with ambient temperature.

SPECIAL EXECUTIONS ON REQUEST

- Stainless steel tube.
- Different lengths.



ELESA Original design

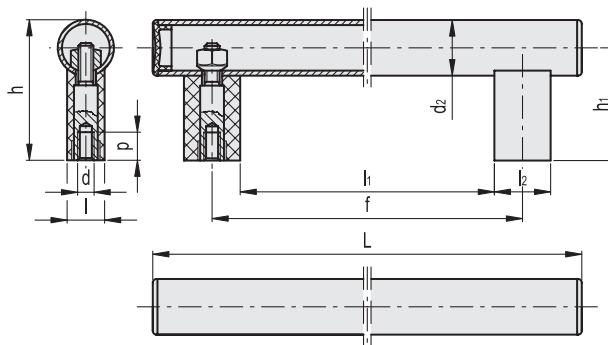
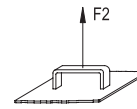

Code	Description	f±1	L	d	h	h1	l	l1	l2	d2	p	F2 [N]*	F2 [N]#	⚖️
151501	M.1066 BM/30-200 CLEAN	200	265	M8	75	60	18	170	30	30	15	4400	6500	240
151506	M.1066 BM/30-250 CLEAN	250	315	M8	75	60	18	220	30	30	15	3500	6000	260
151511	M.1066 BM/30-300 CLEAN	300	365	M8	75	60	18	270	30	30	15	3300	5700	280
151513	M.1066 BM/30-350 CLEAN	350	415	M8	75	60	18	320	30	30	15	3300	5700	300
151516	M.1066 BM/30-400 CLEAN	400	465	M8	75	60	18	370	30	30	15	2400	4500	320
151521	M.1066 BM/30-500 CLEAN	500	565	M8	75	60	18	470	30	30	15	1500	3800	360
151526	M.1066 BM/30-600 CLEAN	600	665	M8	75	60	18	570	30	30	15	880	3200	380

* Maximum working load # Load at breakage