

Indexing plungers

Visually Detectable SUPER-technopolymer body

THREADED BODY

Special glass-fibre reinforced polyamide based (PA) SUPER-technopolymer, blue colour RAL 5005.

PLUNGER

AISI 303 stainless steel.

Suggested tolerance for matching hole = H7.

KNOB

High-resilience polyamide based (PA) technopolymer, RAL 5005 blue colour, matte finish.

Produced from FDA compliant raw material (FDA CFR.21 and EU 10/2011).

SPRING

AISI 302 stainless steel.

LOCKING NUT

NTT-VD: Special glass-fibre reinforced polyamide based (PA) SUPER-technopolymer, blue colour RAL 5005.

Available also as accessory sold separately (see table).

STANDARD EXECUTIONS

- **PMT.100-SST-A-VD:** without locking nut.
- **PMT.100-SST-AK-VD:** with locking nut, supplied not assembled.

FEATURES AND APPLICATIONS

- The RAL 5005 blue colour is easily visible in case of accidental food contamination.
- Resistant to several cleaning cycles with solvents and other chemical agents, for this reason they are suitable for applications as in the pharmaceutical or food industry.
- Anticorrosive material: suitable even in the presence of liquid or humidity.
- Lightness and high mechanical resistance of the product.
- The SUPER-technopolymer threaded body of the plunger offers a low friction factor to the plunger stroke; no lubricating maintenance is FDA required.

ACCESSORIES ON REQUEST

NTT-VD: Special glass-fibre reinforced polyamide based (PA) SUPER-technopolymer, blue colour RAL 5005.

ANOTHER STANDARD EXECUTION

PMT.101-SST-VD: (see page -) indexing plungers with rest position.



ELESA Original design

ASSEMBLY INSTRUCTIONS

Make sure that no machining residues are left on the threaded hole for the assembly indexing plunger (see fig. 1). Do not make any chamfering in the hole (see fig. 2).

SUPER-technopolymer product based on ELESA technology, dimensions according to GN 617 standards as agreed with Otto Ganter GmbH Co. KG.

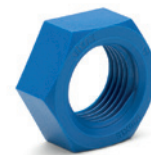
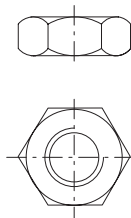
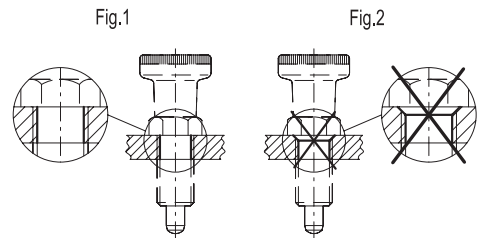

NTT-VD

Code	Description
191083	NTT-M10x1-VD
191085	NTT-M12x1,5-VD
191087	NTT-M16x1,5-VD
191089	NTT-M20x1,5-VD

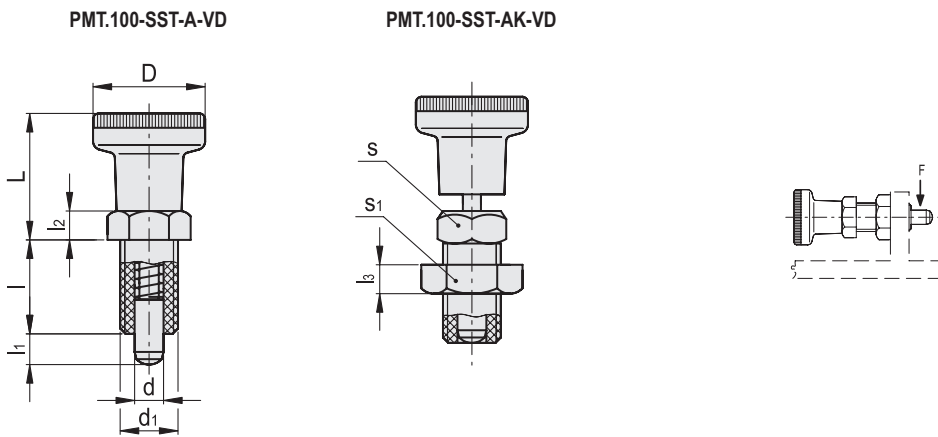

PMT.100-SST-A-VD

STAINLESS STEEL

Code	Description	d Plunger Hole H7 -0.15 -0.1	d ₁	L	D	I	l ₁	l ₂	s	[N]* [N]#	Max. tightening torque [Nm]	Static load at breakage F [N]		
194551	PMT.100-SST-5-M10x1-A-VD	5	M10x1	23	21	17	5	5	12	7	17	5	1800	10
194552	PMT.100-SST-6-M12x1,5-A-VD	6	M12x1.5	28	25	20	6	6	14	9	24	10	2900	20
194561	PMT.100-SST-8-M16x1,5-A-VD	8	M16x1.5	35	31	26	8	8	19	11	30	18	4400	37
194562	PMT.100-SST-10-M20x1,5-A-VD	10	M20x1.5	37	31	33	10	10	22	19	45	25	6800	55

PMT.100-SST-AK-VD

STAINLESS STEEL

Code	Description	d Plunger Hole H7 -0.15 -0.1	d ₁	L	D	I	l ₁	l ₂	l ₃	s	s ₁	[N]* [N]#	Max. tightening torque [Nm]	Static load at breakage F [N]		
194571	PMT.100-SST-5-M10x1-AK-VD	5	M10x1	23	21	17	5	5	7	12	16	7	17	5	1800	13
194572	PMT.100-SST-6-M12x1,5-AK-VD	6	M12x1.5	28	25	20	6	6	8	14	19	9	24	10	2900	23
194581	PMT.100-SST-8-M16x1,5-AK-VD	8	M16x1.5	35	31	26	8	8	10	19	24	11	30	18	4400	42
194582	PMT.100-SST-10-M20x1,5-AK-VD	10	M20x1.5	37	31	33	10	10	11	22	30	19	45	25	6800	63

* Spring preload

Spring maximum load



00

Indexing elements