

Flush pull handles

for snap-in assembly, technopolymer certified self-extinguishing

MATERIAL

Glass-fibre reinforced polyamide based (PA) technopolymer certified self-extinguishing UL-94 V0, grey-black colour, matte finish.

STANDARD EXECUTION

Snap-in assembly (see Assembly Instructions).

ERGONOMY AND DESIGN

A modern design thanks to the compact shape. The internal profile of the cavity offers a safe, comfortable and ergonomic grip.

TECHNICAL DATA

The "V0" certification in accordance with UL-94 V (Underwriters Laboratories) (see Technical Data on page A5) indicates that on a plastic test sample with specific shape and dimensions, in the vertical position, the flame is extinguished within 10 seconds, without generating any incandescent drops.

The lifting (F1) and pull out (F2) resistance values reported in the table are the result of the tests carried out in laboratory with handles assembled on strengthened metal sheet panels with thickness = 1.5 mm (strengthened for test purposes).

ASSEMBLY INSTRUCTIONS

1. Drill the handle housing according to the template dimensions reported in the table.
2. Remove all drilling burrs before fitting the handle.
3. Fit the upper part of the handle into the housing (Fig. 1).
4. Press onto the lower part until the handle is completely snapped in (Fig. 2).

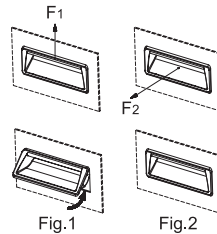

ELESA Original design

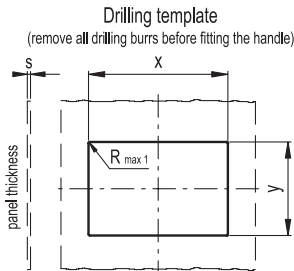

	PR.92-PF AE-V0		PR.137-PF AE-V0		PR.189-PF AE-V0	
s	x	y	x	y	x	y
7 ⁺¹	87.5 ^{+0.2}	30.7 ^{±0.1}	132 ^{+0.2}	30.6 ^{±0.1}	183.7 ^{+0.2}	39.6 [±]
1 ^{+1.5}	87.5 ^{+0.2}	30.9 ^{±0.1}	132 ^{+0.2}	30.8 ^{±0.1}	183.7 ^{+0.2}	40.0 [±]
.5 ⁺²	87.5 ^{+0.2}	31.9 ^{±0.1}	132 ^{+0.2}	31.8 ^{±0.1}	183.7 ^{+0.2}	40.3 [±]
2 ^{+2.2}	87.5 ^{+0.2}	31.9 ^{±0.1}	132 ^{+0.2}	31.8 ^{±0.1}	183.7 ^{+0.2}	40.3 [±]

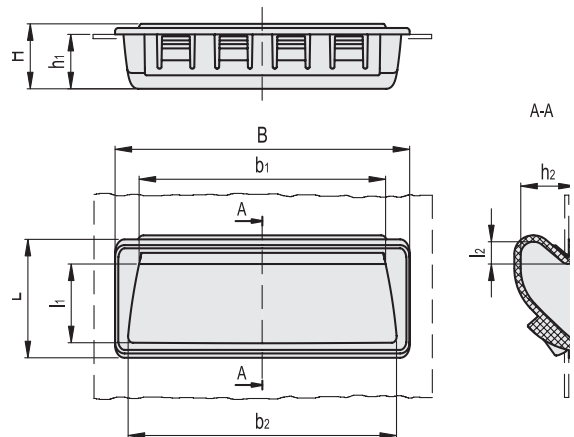

Code	Description	B	L	H	h1	h2	b1	b2	l1	l2	F1 [N]	F2 [N]	⚖
150701-C1	PR.92-PF-AE-V0-C1	92	37	19	17	17	76	83	25	7	1800	500	19
150711-C1	PR.137-PF-AE-V0-C1	137	37	19	17	17	122	128	25	7	1800	500	28



U-Handles 4