

Castors for general use

Injected polyurethane coating

COVERING

Injected polyurethane, hardness 55 Shore D.

WHEEL CENTRE BODY

Polyamide based (PA) technopolymer.

ROLLING ACTION

Hub with pass-through hole.

FIXED PLATE BRACKET

Electrolytically zinc-plated steel sheet bracket.

TURNING PLATE BRACKET

Electrolytically zinc-plated steel sheet bracket.

The presence of a double ball race and direct contact between the plate and the ball race ring with built-in pin ensure excellent manoeuvrability.

FRONT-ACTUATED BRAKE

Total brake that locks rotation of the wheel and the technopolymer bracket.

The optimised dimensions and the retractable pedal ensure minimal space occupied and maximum actuation ease.

STANDARD EXECUTIONS

- **PBL**: fixed plate bracket, without brake.
- **SBL**: turning plate bracket, without brake.
- **SBF**: turning plate bracket, with brake.
- **CBL**: turning plate bracket and threaded centre pin, without brake.
- **CBF**: turning plate bracket and threaded centre pin, with brake.
- **FBL**: turning plate bracket and centre pass-through hole, without brake.
- **FBF**: turning plate bracket and centre pass-through hole, with brake.

APPLICATIONS

Castors for the general public, excellent rolling resistance and elasticity features, high wear and tearing resistance.

ENVIRONMENTAL CONDITIONS

Suitable for use in industrial and institutional environments, even in the presence of moisture and chemical agents.

The good resistance to frequent cleaning cycles makes it suitable for environments where it is necessary to ensure hygiene.



RE.C6-PBL-C

RE.C6-SBL-C

RE.C6-SBF-C

RE.C6-CBL-C

RE.C6-CBF-C

RE.C6-FBL-C

RE.C6-FBF-C

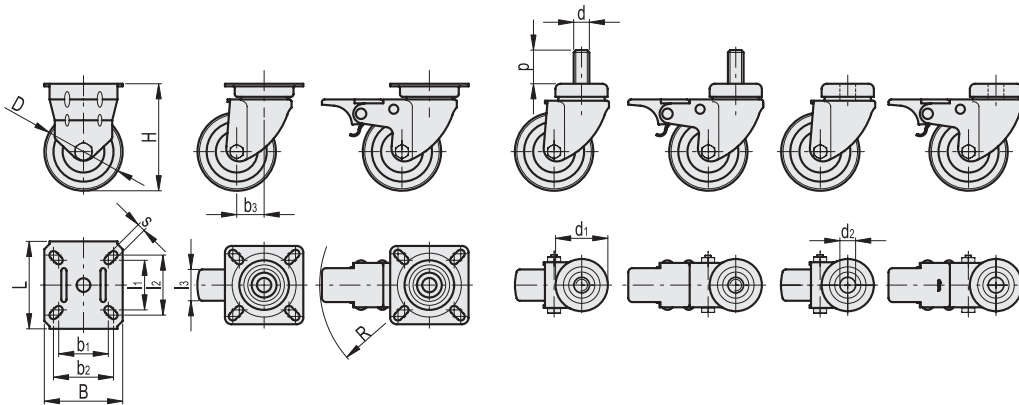

RE.C6-PBL

Code	Description	D	l ₁	l ₂	l ₃	H	B	L	s	b ₁	b ₂	Dynamic carrying capacity# [N]	⚖️
451946	RE.C6-040-PBL-C	40	27	33	18	59	48	48	5	27	33	400	110
451948	RE.C6-050-PBL-C	50	38.5	44	18	66	55	55	6	38.5	44	550	149
451950	RE.C6-060-PBL-C	60	38.5	47	24	82	60	67	6	38.5	47	700	210

RE.C6-SBL

Code	Description	D	l ₁	l ₂	l ₃	H	B	L	s	b ₁	b ₂	b ₃	Dynamic carrying capacity# [N]	⚖️
451926	RE.C6-040-SBL-C	40	30	33	18	59	42	42	5	30	33	24	400	110
451928	RE.C6-050-SBL-C	50	38.5	44	18	66	55	55	6	38.5	44	24	550	130
451930	RE.C6-060-SBL-C	60	38.5	48	24	82	60	60	6	38.5	48	21	700	240

RE.C6-SBF

Code	Description	D	l ₁	l ₂	l ₃	H	B	L	s	b ₁	b ₂	b ₃	R	Dynamic carrying capacity# [N]	⚖️
451936	RE.C6-040-SBF-C	40	30	33	18	59	42	42	5	30	33	24	78	400	130
451938	RE.C6-050-SBF-C	50	38.5	44	18	66	55	55	6	38.5	44	24	78	550	160
451940	RE.C6-060-SBF-C	60	38.5	48	24	82	60	67	6	38.5	48	21	83	700	280

RE.C6-CBL

Code	Description	D	d	p	d ₁	l ₃	H	b ₃	Dynamic carrying capacity# [N]	⚖️
451956	RE.C6-040-CBL-C	40	M10	20	35	18	59	24	400	120
451958	RE.C6-050-CBL-C	50	M10	20	35	18	66	24	550	130
451960	RE.C6-060-CBL-C	60	M12	25	42	24	82	21	700	240

RE.C6-CBF

Code	Description	D	d	p	d ₁	l ₃	H	b ₃	R	Dynamic carrying capacity# [N]	⚖️
451966	RE.C6-040-CBF-C	40	M10	20	35	18	59	24	78	400	140
451968	RE.C6-050-CBF-C	50	M10	20	35	18	66	24	78	550	160
451970	RE.C6-060-CBF-C	60	M12	25	42	24	82	21	83	700	280

RE.C6-FBL

Code	Description	D	d ₁	d ₂	l ₃	H	b ₃	Dynamic carrying capacity# [N]	⚖️
451976	RE.C6-040-FBL-C	40	35	10	18	59	24	400	100
451978	RE.C6-050-FBL-C	50	35	10	18	66	24	550	130
451980	RE.C6-060-FBL-C	60	42	12	24	82	21	700	240

RE.C6-FBF

Code	Description	D	d ₁	d ₂	l ₃	H	b ₃	R	Dynamic carrying capacity# [N]	⚖️
451986	RE.C6-040-FBF-C	40	35	10	18	59	24	78	400	120
451988	RE.C6-050-FBF-C	50	35	10	18	66	24	78	550	130
451990	RE.C6-060-FBF-C	60	42	12	24	82	21	83	700	250

For dynamic carrying capacity see Technical data (on page -).

