

Twin castors for the general public with steel bracket

Injected polyurethane coating

COVERING

Injected polyurethan, hardness 55 Shore D.

WHEEL CENTRE BODY

Polyamide-based technopolymer (PA).

ROLLING ACTION

Hub with pass-through hole.

TURNING PLATE BRACKET

Electrolytically zinc-plated steel sheet bracket.

The presence of a double ball race turns and the direct contact between the plate and the ball race ring with built-in pin ensure excellent manoeuvrability.

FRONT-ACTUATED BRAKE

Total brake that locks rotation of the wheel and the technopolymer bracket.

The optimised dimensions and the retractable pedal ensure minimal space occupied and maximum actuation ease.

STANDARD EXECUTIONS

- **SBL-G**: turning plate bracket, without brake.
- **SBF-G**: turning plate bracket, with brake.
- **CBL-G**: turning plate bracket and threaded centre pin, without brake.
- **CBF-G**: turning plate bracket and threaded centre pin, with brake.
- **FBL-G**: turning plate bracket and centre pass-through hole, without brake.
- **FBF-G**: turning plate bracket and centre pass-through hole, with brake.

APPLICATIONS

Wheels for the general public with high carrying capacity, excellent smoothness and elasticity features, good wear and tearing resistance.

ENVIRONMENTAL CONDITIONS

RE.C6 twin wheels are suitable for use in industrial and institutional environments, even in the presence of moisture and chemical agents. The good resistance to frequent cleaning cycles makes it suitable for environments where it is necessary to ensure hygiene.



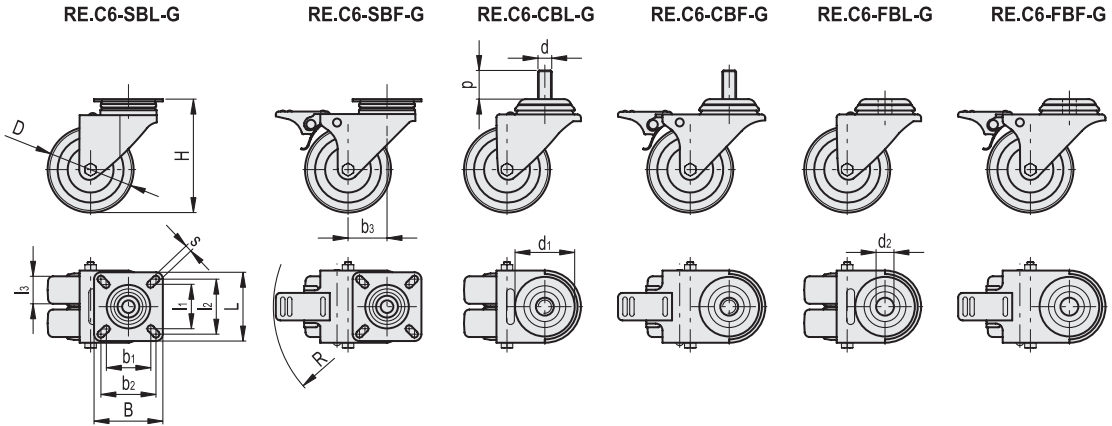

RE.C6-SBL-G

Code	Description	D	l ₁	l ₂	l ₃	H	B	L	s	b ₁	b ₂	b ₃	Dynamic carrying capacity# [N]	⚖️
451929	RE.C6-050-SBL-G	50	38.5	48	18	71	60	60	6	38.5	48	25.5	1400	300

RE.C6-SBF-G

Code	Description	D	l ₁	l ₂	l ₃	H	B	L	s	b ₁	b ₂	b ₃	R	Dynamic carrying capacity# [N]	⚖️
451939	RE.C6-050-SBF-G	50	38.5	48	18	71	60	60	6	38.5	48	25.5	83	1400	350

RE.C6-CBL-G

Code	Description	D	d	p	d ₁	l ₃	H	b ₃	Dynamic carrying capacity# [N]	⚖️
451959	RE.C6-050-CBL-G	50	M10	25	52	18	71	25.5	1400	310

RE.C6-CBF-G

Code	Description	D	d	p	d ₁	l ₃	H	b ₃	R	Dynamic carrying capacity# [N]	⚖️
451969	RE.C6-050-CBF-G	50	M10	25	52	18	71	25.5	83	1400	360

RE.C6-FBL-G

Code	Description	D	d ₁	d ₂	l ₃	H	b ₃	R	Dynamic carrying capacity# [N]	⚖️
451979	RE.C6-050-FBL-G	50	55	10	18	71	25.5	83	1400	270

RE.C6-FBF-G

Code	Description	D	d ₁	d ₂	l ₃	H	b ₃	R	Dynamic carrying capacity# [N]	⚖️
451989	RE.C6-050-FBF-G	50	55	10	18	71	25.5	83	1400	320

For dynamic carrying capacity see Technical data (on page -).

