

Castors with steel bracket

Vulcanised rubber coating

COVERING WITH TREAD

Vulcanised rubber; hardness 80 Shore A.

WHEEL CENTRE BODY

Consisting of two zinc-plated and riveted sheet disks.

ROLLING ACTION

Polyamide-based technopolymer (PA) hub and boss, integral to the wheel centre body.

FIXED PLATE BRACKET

Zinc-plated steel sheet, the bracket is designed to withstand loads up to 2300N.

TURNING PLATE BRACKET

Zinc-plated steel sheet, the bracket is designed to withstand loads up to 2300N. The presence of a double ball race turns and the direct contact between the plate and the ball race ring with built-in pin ensure excellent manoeuvrability. Does not require maintenance. It consists of (see Fig.1):

1. fitting plate: electrolytically zinc-plated steel sheet;
2. fork: electrolytically zinc-plated steel sheet;
3. ball race ring: electrolytically zinc-plated steel sheet;
4. central pin: incorporated in the plate, cold reflanged;
5. rotation system: dual grease-lubricated ball race;
6. dust seal: RAL 7015 dark grey technopolymer.

BRAKE

Total brake that locks the wheel and bracket rotation. The optimised dimensions and the retractable pedal ensure minimal space occupied and maximum actuation ease. Hardened carbon steel spring.

STANDARD EXECUTIONS (BORE WITH PLAIN BEARING)

- **PBL-N**: fixed plate bracket, without brake.
- **SBL-N**: turning plate bracket, without brake.
- **SBF-N**: turning plate bracket, with brake.
- **FBL-N**: turning plate bracket and centre pass-through hole, without brake.
- **FBF-N**: turning plate bracket and centre pass-through hole, with brake.

APPLICATIONS

RE.E3 wheels may be mounted on different kinds of trolleys, with medium-light loads; it is also suitable for outdoor use. Typical applications: trolleys for industrial moving, for outdoor use also, waste dumpsters.

For further information see RE.E3 on page .



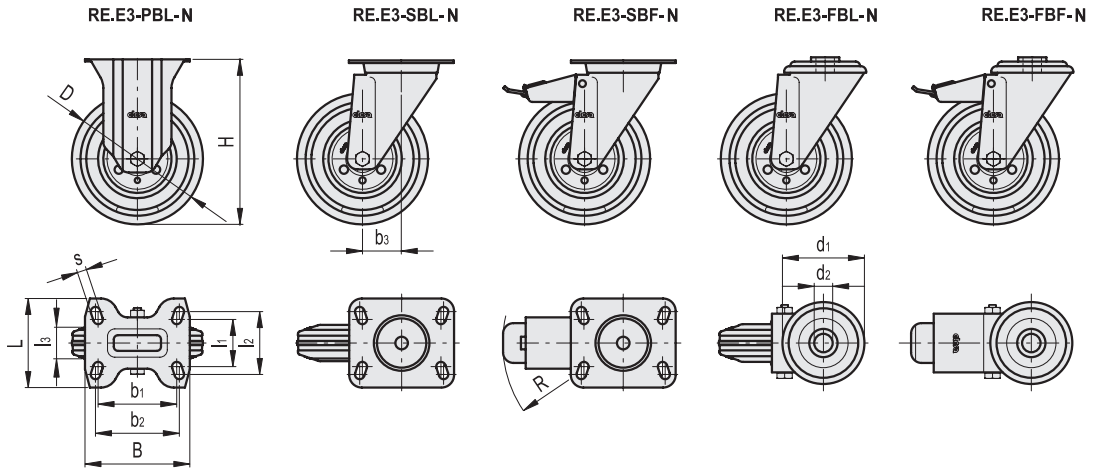

Code	Description	D	d1	d2	b1	l1	b2	l2	l3	H	B	L	s	b3	R	Rolling resistance# [N]	Dynamic carrying capacity# [N]	⚖️
450151	RE.E3-080-PBL-N	80	-	-	75	45	80	60	25	107	100	85	9	-	-	600	650	490
450156	RE.E3-100-PBL-N	100	-	-	75	45	80	60	30	128	100	85	9	-	-	750	800	620
450161	RE.E3-125-PBL-N	125	-	-	75	45	80	60	37.5	156	100	85	9	-	-	850	1300	920
450166	RE.E3-150-PBL-N	150	-	-	75	45	80	60	40	182	100	85	9	-	-	1000	1700	1220
450171	RE.E3-200-PBL-N	200	-	-	105	73	105	85	50	240	140	114	11	-	-	1400	2300	2890
450051	RE.E3-080-SBL-N	80	-	-	75	45	80	60	25	107	100	85	9	40	-	600	650	690
450056	RE.E3-100-SBL-N	100	-	-	75	45	80	60	30	128	100	85	9	35	-	750	800	820
450061	RE.E3-125-SBL-N	125	-	-	75	45	80	60	37.5	156	100	85	9	37	-	850	1300	1180
450066	RE.E3-150-SBL-N	150	-	-	75	45	80	60	40	182	100	85	9	34	-	1000	1700	1400
450071	RE.E3-200-SBL-N	200	-	-	105	73	105	87	50	240	140	110	11	56	-	1400	2300	3250
450101	RE.E3-080-SBF-N	80	-	-	75	45	80	60	25	107	100	85	9	40	120	600	650	870
450106	RE.E3-100-SBF-N	100	-	-	75	45	80	60	30	128	100	85	9	35	120	750	800	1000
450111	RE.E3-125-SBF-N	125	-	-	75	45	80	60	37.5	156	100	85	9	37	120	850	1300	1300
450116	RE.E3-150-SBF-N	150	-	-	75	45	80	60	40	182	100	85	9	34	120	1000	1700	1570
450121	RE.E3-200-SBF-N	200	-	-	105	73	105	87	50	240	140	110	11	56	156	1400	2300	3390
450201	RE.E3-080-FBL-N	80	73	12	-	-	-	-	25	107	-	-	-	40	-	600	650	690
450206	RE.E3-100-FBL-N	100	73	12	-	-	-	-	30	128	-	-	-	35	-	750	800	820
450211	RE.E3-125-FBL-N	125	73	12	-	-	-	-	37.5	156	-	-	-	37	-	850	1300	1180
450216	RE.E3-150-FBL-N	150	73	12	-	-	-	-	40	182	-	-	-	34	-	1000	1700	1400
450221	RE.E3-200-FBL-N	200	102	20	-	-	-	-	50	236	-	-	-	56	-	1400	2300	3250
450251	RE.E3-080-FBF-N	80	73	12	-	-	-	-	25	107	-	-	-	40	120	600	650	870
450256	RE.E3-100-FBF-N	100	73	12	-	-	-	-	30	128	-	-	-	35	120	750	800	1000
450261	RE.E3-125-FBF-N	125	73	12	-	-	-	-	37.5	156	-	-	-	37	120	850	1300	1300
450266	RE.E3-150-FBF-N	150	73	12	-	-	-	-	40	182	-	-	-	34	120	1000	1700	1570
450271	RE.E3-200-FBF-N	200	102	20	-	-	-	-	50	236	-	-	-	56	156	1400	2300	3390

For rolling resistance and dynamic carrying capacity see Technical data on page .

