

Castors with steel bracket

Soft polyurethane coating

COVERING

Soft mould-on polyurethane, hardness 75 Shore A.

WHEEL CENTRE BODY

Pressure die-cast aluminium.

ROLLING ACTION

Hub with ball bearings. Ideal solution for heavy loads and continuous moving.

FIXED PLATE BRACKET

Zinc-plated steel sheet, the bracket is designed to withstand loads up to 2000N.

TURNING PLATE BRACKET

Zinc-plated steel sheet, the bracket is designed to withstand loads up to 2000N.

The presence of a double ball race turns and the direct contact between the plate and the ball race ring with built-in pin ensure excellent manoeuvrability.

Does not require maintenance.

It consists of (see Fig.1):

1. fitting plate: electrolytically zinc-plated steel plate;
2. fork: electrolytically zinc-plated steel plate;
3. ball race ring: electrolytically zinc-plated steel plate;
4. central pin: incorporated in the plate, cold reflanged;
5. rotation system: dual grease-lubricated ball race;
6. dust seal: RAL 7015 dark grey technopolymer.

BRAKE

Total brake that locks the wheel and bracket rotation.

The optimised dimensions and the retractable pedal ensure minimal space occupied and maximum actuation ease.

Hardened carbon steel spring.

The trolley must be turned to use the device.

The brake is simple and effective to use: it is actuated and released by a simple action from the top downward at the tip of two separate pedals, thus ensuring the utmost manoeuvring comfort.

STANDARD EXECUTIONS

- **PSL-N**: fixed plate bracket, without brake.
- **SSL-N**: turning plate bracket, without brake.
- **SSF-N**: turning plate bracket, with brake.

APPLICATIONS

Excellent smoothness and elasticity features, high wear and tearing resistance.

For further information see RE.F2 (on page -).



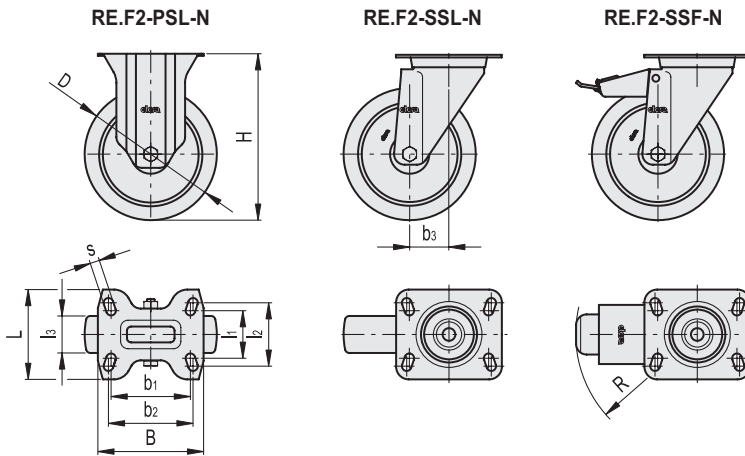

Code	Description	D	l1	l2	l3	H	B	L	s	b1	b2	b3	R	Rolling resistance# [N]	Dynamic carrying capacity# [N]	
452466	RE.F2-100-PSL-N	100	45	60	40	128	100	85	9	75	80	-	-	3000	2000	690
452426	RE.F2-100-SSL-N	100	45	60	40	128	100	85	9	75	80	35	-	3000	2000	940
452446	RE.F2-100-SSF-N	100	45	60	40	128	100	85	9	75	80	35	120	3000	2000	1080

For rolling resistance and dynamic carrying capacity see Technical data on page -.