

Castors with steel bracket

Mould-on polyurethane coating

COVERING

Mould-on polyurethane, hardness 92 Shore A.

WHEEL CENTRE BODY

Pressure die-cast aluminium.

ROLLING ACTION

Hub with ball bearings. Ideal solution for heavy loads and continuous moving.

FIXED PLATE BRACKET

Zinc-plated steel sheet, the bracket is designed to withstand loads up to 3000N.

TURNING PLATE BRACKET

Zinc-plated steel sheet, the bracket is designed to withstand loads up to 3000N.

The presence of a double ball race turns and the direct contact between the plate and the ball race ring with built-in pin ensure excellent manoeuvrability.

Does not require maintenance.

It consists of (see Fig.1):

1. fitting plate: electrolytically zinc-plated steel plate;
2. fork: electrolytically zinc-plated steel plate;
3. ball race ring: electrolytically zinc-plated steel plate;
4. central pin: incorporated in the plate, cold reflanged;
5. rotation system: dual grease-lubricated ball race;
6. dust seal: RAL 7015 dark grey technopolymer, available only for SSL and SSF executions.

BRAKE

Total brake that locks the wheel and bracket rotation.

The optimised dimensions and the retractable pedal ensure minimal space occupied and maximum actuation ease.

Hardened carbon steel spring.

The trolley must be turned to use the device.

The brake is simple and effective to use: it is actuated and released by a simple action from the top downward at the tip of two separate pedals, thus ensuring the utmost manoeuvring comfort.

STANDARD EXECUTIONS

- **PSL-N**: fixed plate bracket, without brake.
- **SSL-N**: turning plate bracket, without brake.
- **SSF-N**: turning plate bracket, with brake.
- **FSL-N**: turning plate bracket and centre pass-through hole, without brake.
- **FSF-N**: turning plate plate and centre pass-through hole, with brake.

APPLICATIONS

Excellent smoothness and elasticity features, high wear and tearing resistance.

For further information see RE.F5 (on page).



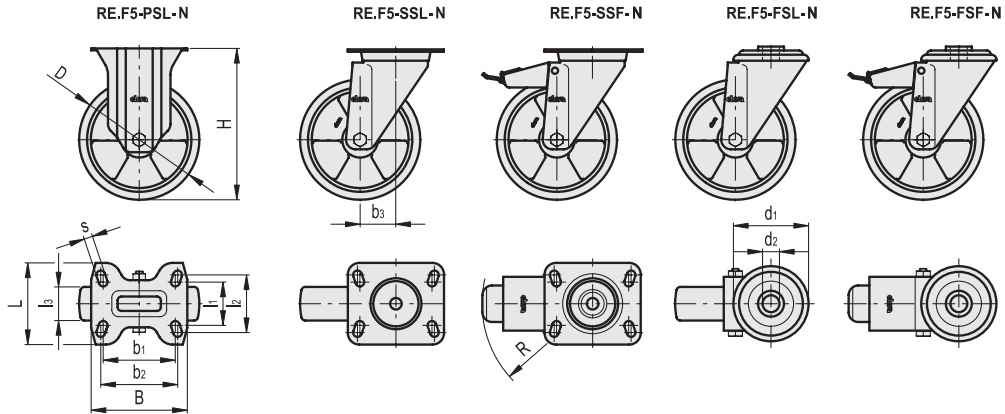

Code	Description	D	d1	d2	l1	l2	l3	H	B	L	s	b1	b2	b3	R	Rolling resistance# [N]	Dynamic carrying capacity# [N]	⚖
451651	RE.F5-080-PSL-N	80	-	-	45	60	25	107	100	85	9	75	80	-	-	1500	2000	520
451656	RE.F5-100-PSL-N	100	-	-	45	60	30	128	100	85	9	75	80	-	-	2250	2000	690
451661	RE.F5-125-PSL-N	125	-	-	45	60	35	156	100	85	9	75	80	-	-	2800	2200	890
451666	RE.F5-150-PSL-N	150	-	-	73	85	40	194	140	114	11	105	105	-	-	3300	3000	2040
451671	RE.F5-200-PSL-N	200	-	-	73	85	50	240	140	114	11	105	105	-	-	3600	3000	2760
451551	RE.F5-080-SSL-N	80	-	-	45	60	25	107	100	85	9	75	80	40	-	1500	2000	720
451556	RE.F5-100-SSL-N	100	-	-	45	60	30	128	100	85	9	75	80	35	-	2250	2000	940
451561	RE.F5-125-SSL-N	125	-	-	45	60	35	156	100	85	9	75	80	37	-	2800	2200	1140
451565	RE.F5-150-SSL-N	150	-	-	73	87	40	194	140	110	11	105	105	56	-	3300	3000	2340
451571	RE.F5-200-SSL-N	200	-	-	73	87	50	240	140	110	11	105	105	56	-	3600	3000	3050
451601	RE.F5-080-SSF-N	80	-	-	45	60	25	107	100	85	9	75	80	40	120	1500	2000	910
451606	RE.F5-100-SSF-N	100	-	-	45	60	30	128	100	85	9	75	80	35	120	2250	2000	1080
451611	RE.F5-125-SSF-N	125	-	-	45	60	35	156	100	85	9	75	80	37	120	2800	2200	1280
451615	RE.F5-150-SSF-N	150	-	-	73	87	40	194	140	110	11	105	105	56	156	3300	3000	2630
451621	RE.F5-200-SSF-N	200	-	-	73	87	50	240	140	110	11	105	105	56	156	3600	3000	3250
451851	RE.F5-080-FSL-N	80	73	12	-	-	25	107	-	-	-	-	-	40	-	1500	2000	650
451856	RE.F5-100-FSL-N	100	73	12	-	-	30	128	-	-	-	-	-	35	-	2250	2000	880
451861	RE.F5-125-FSL-N	125	73	12	-	-	35	156	-	-	-	-	-	37	-	2800	2200	1080
451866	RE.F5-150-FSL-N	150	102	20	-	-	40	188	-	-	-	-	-	56	-	3300	3000	2200
451871	RE.F5-200-FSL-N	200	102	20	-	-	50	236	-	-	-	-	-	56	-	3600	3000	2950
451901	RE.F5-080-FSF-N	80	73	12	-	-	25	107	-	-	-	-	-	40	120	1500	2000	780
451906	RE.F5-100-FSF-N	100	73	12	-	-	30	128	-	-	-	-	-	35	120	2250	2000	1020
451911	RE.F5-125-FSF-N	125	73	12	-	-	35	156	-	-	-	-	-	37	120	2800	2200	1230
451916	RE.F5-150-FSF-N	150	102	20	-	-	40	188	-	-	-	-	-	56	156	3300	3000	2490
451921	RE.F5-200-FSF-N	200	102	20	-	-	50	236	-	-	-	-	-	56	156	3600	3000	3240

For rolling resistance and dynamic carrying capacity see Technical data on page .

