

Castors with stainless steel bracket

Duroplast, high temperatures

WHEEL BODY

Phenolic based (PF) Duroplast monolithic wheel, resistant to temperatures up to 300°C.

ROLLING ACTION

Hub with stainless steel tube and PTFE bosses.

TURNING PLATE BRACKET

AISI 304 stainless steel sheet, the bracket is designed to withstand loads up to 2000N. The presence of two ball turns and the direct contact between the plate and the ball race ring with built-in pin ensure excellent manoeuvrability. Does not require maintenance. It consists of (see Fig.1):

1. fitting plate: AISI 304 stainless steel sheet;
2. fork: AISI 304 stainless steel sheet;
3. ball race ring: AISI 304 stainless steel sheet;
4. central pin: incorporated in the plate, cold reflanged;
5. rotation system: dual ball ring, high temperature grease-lubricated;
6. dust seal: RAL 7015 dark grey technopolymer.

STANDARD EXECUTIONS

- **SBL**: turning plate bracket, without brake.
- **FBL**: turning plate bracket and centre pass-through hole, without brake.

APPLICATIONS

Being resistant to high temperatures, RE.F7-SST-N-HT castor is particularly suitable for use in food industries and cooking ovens, especially in the baking sector.

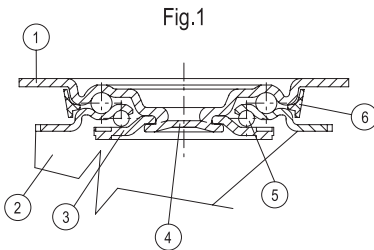

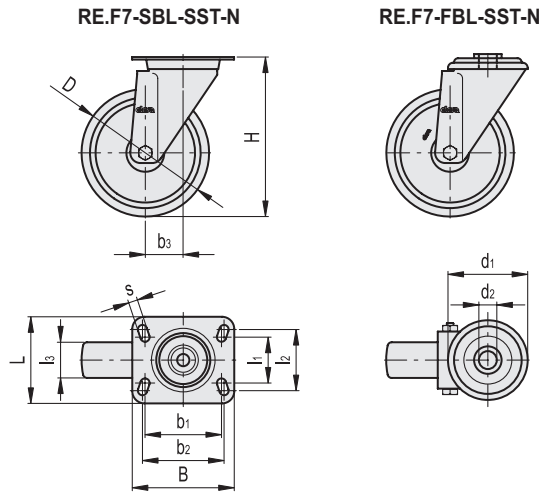

RE.F7-SBL-SST-N-HT

STAINLESS STEEL

Code	Description	D	l1	l2	l3	H	B	L	s	b1	b2	b3	Rolling resistance# [N]	Dynamic carrying capacity# [N]	
448701	RE.F7-080-SBL-SST-N-HT	80	45	60	35	107	100	85	9	75	80	40	1250	1500	710
448706	RE.F7-100-SBL-SST-N-HT	100	45	60	35	128	100	85	9	75	80	35	1300	2000	790

RE.F7-FBL-SST-N-HT

STAINLESS STEEL

Code	Description	D	d1	d2	l3	H	b3	Rolling resistance# [N]	Dynamic carrying capacity# [N]	
448851	RE.F7-080-FBL-SST-N-HT	80	73	12	35	107	40	1250	1500	620
448856	RE.F7-100-FBL-SST-N-HT	100	73	12	35	128	35	1300	2000	720

For rolling resistance and dynamic carrying capacity see Technical data (on page).