

Castors with bracket for medium-heavy loads

Technopolymer monolithic wheels

WHEEL CENTRE BODY

Polyamide-based (PA) technopolymer.

ROLLING ACTION

Hub with pass-through hole.

FIXED PLATE BRACKET

Yellow zinc-plated steel sheet. The bracket is designed to withstand loads up to 7300N. It ensures capacities that make it suitable for heavy industrial applications.

TURNING PLATE BRACKET

Yellow zinc-plated steel sheet. The presence of a double ball race turns and the direct contact between the plate and the ball race ring with built-in pin ensure excellent manoeuvrability. Does not require maintenance. The bracket is designed to withstand loads up to 7300N. It ensures capacities that make it suitable for heavy industrial applications.

It consists of (see fig.1):

1. fitting plate: yellow zinc-plated steel sheet;
2. fork: yellow zinc-plated steel sheet;
3. ball race ring: yellow zinc-plated steel sheet;
4. central pin: class 8,8 steel screw and steel nut;
5. rotation system: dual grease-lubricated ball race;
6. dust seal: RAL 7015 dark grey technopolymer.

BRAKE

Front brake (RE.F8-100-125) or rear brake (RE.F8-150-200) dual-effect with simultaneous locking of wheel and bracket. The brake is simple and effective to use: it is actuated and released by a simple action from the top downward at the tip of two separate pedals, thus ensuring the utmost manoeuvring comfort. On wheels with a rear brake, the braking efficacy may be adjusted with a socket head screw M8.

STANDARD EXECUTIONS

- **PBL-H**: fixed bracket, without brake.
- **SBL-H**: turning plate bracket, without brake.
- **SBF-H**: turning plate bracket, with brake.

APPLICATIONS

Suitable for heavy industrial applications. Excellent wear and tearing resistance. For further information see RE.F8 (on page).

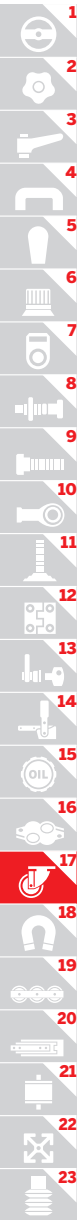

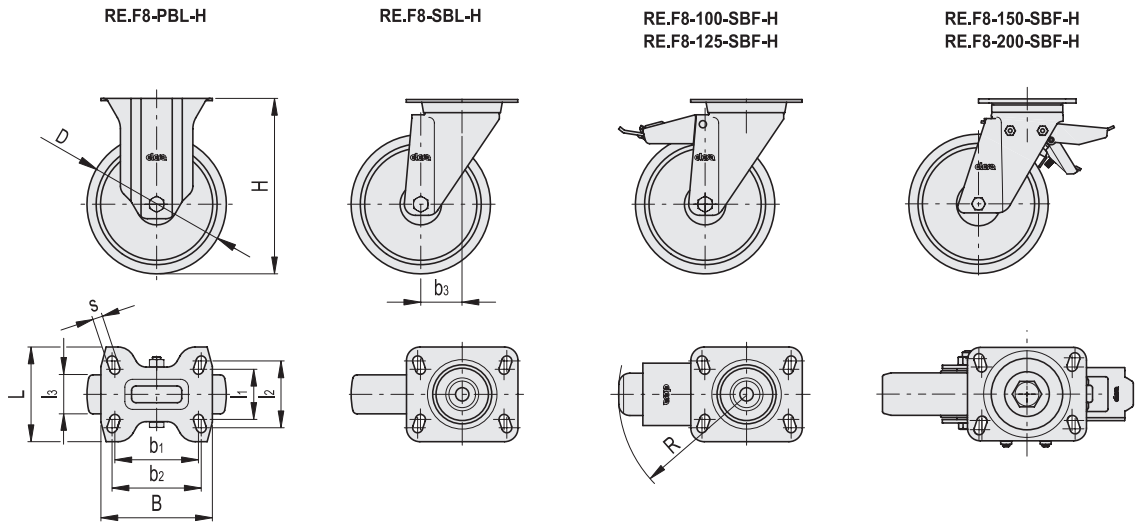

Code	Description	D	l1	l2	l3	H	B	L	s	b1	b2	b3	R	Rolling resistance# [N]	Dynamic carrying capacity# [N]	⚖️
450951	RE.F8-100-PBL-H	100	45	60	30	138	100	85	9	75	80	-	-	1750	3000	600
450952	RE.F8-125-PBL-H	125	45	60	38	161	100	85	9	75	80	-	-	2000	3500	640
450953	RE.F8-150-PBL-H	150	73	85	45	200	140	110	11	105	105	-	-	2500	5000	1670
450954	RE.F8-200-PBL-H	200	73	85	50	250	140	110	11	105	105	-	-	4550	7300	1650
450931	RE.F8-100-SBL-H	100	45	60	30	138	100	85	9	75	80	48	-	1750	3000	990
450932	RE.F8-125-SBL-H	125	45	60	38	161	100	85	9	75	80	44	-	2000	3500	1160
450933	RE.F8-150-SBL-H	150	73	87	45	200	140	110	11	105	105	70	-	2500	5000	2800
450934	RE.F8-200-SBL-H	200	73	87	50	250	140	110	11	105	105	70	-	4550	7300	3110
450941	RE.F8-100-SBF-H	100	45	60	30	138	100	85	9	75	80	46	123	1750	3000	1140
450942	RE.F8-125-SBF-H	125	45	60	38	161	100	85	9	75	80	44	123	2000	3500	1270
450943	RE.F8-150-SBF-H	150	73	87	45	200	140	110	11	105	105	70	126	2500	5000	2980
450944	RE.F8-200-SBF-H	200	73	87	50	250	140	110	11	105	105	70	126	4550	7300	3390

For rolling resistance and dynamic carrying capacity see Technical data on page .