

Castors with stainless steel bracket

Thermoplastic rubber coating

COVERING

Grey anti-trace thermoplastic wheel, hardness 85 Shore A.

WHEEL CENTRE BODY

Polypropylene-based (PP) technopolymer.

ROLLING ACTION

Hub with pass-through hole.

FIXED PLATE BRACKET

AISI 304 stainless steel sheet, the bracket is designed to withstand loads up to 1800N.

TURNING PLATE BRACKET

AISI 304 stainless steel sheet, the bracket is designed to withstand loads up to 1800N. The presence of two ball turns and the direct contact between the plate and the ball race ring with built-in pin ensure excellent manoeuvrability. Does not require maintenance. It consists of (see Fig.1):

1. fitting plate: AISI 304 stainless steel sheet;
2. fork: AISI 304 stainless steel sheet;
3. ball race ring: AISI 304 stainless steel sheet;
4. central pin: incorporated in the plate, cold refranged;
5. rotation system: dual grease-lubricated ball race;
6. dust seal: RAL 7015 dark grey technopolymer, available only for SBL and SBF executions.

BRAKE

Total brake that locks the wheel and bracket rotation. The optimised dimensions and the retractable pedal ensure minimal space occupied and maximum actuation ease. Hardened carbon steel or stainless steel (SST version) spring.

STANDARD EXECUTIONS

- **PBL**: fixed plate bracket, without brake.
- **SBL**: turning plate bracket, without brake.
- **SBF**: turning plate bracket, with brake.
- **FBL**: turning plate bracket and centre pass-through hole, without brake.
- **FBF**: turning plate bracket and centre pass-through hole, with brake.

APPLICATIONS

Excellent rolling resistance and elasticity features. For further information see wheel technical data sheet RE.G1 (see page).

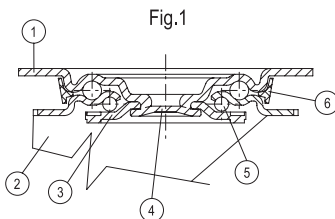

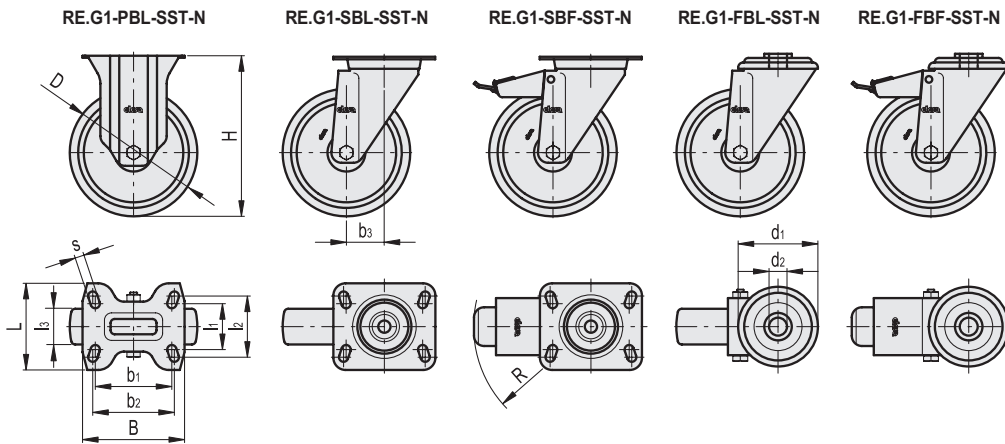

STAINLESS STEEL

Code	Description	D	d1	d2	b1	l1	b2	l2	l3	H	B	L	s	b3	R	Rolling resistance# [N]	Dynamic carrying capacity# [N]	
452653	RE.G1-080-PBL-N-SST	80	-	-	75	45	80	60	30	107	100	85	9	-	-	700	700	590
452658	RE.G1-100-PBL-N-SST	100	-	-	75	45	80	60	30	128	100	85	9	-	-	1000	1000	610
452663	RE.G1-125-PBL-N-SST	125	-	-	75	45	80	60	35	156	100	85	9	-	-	1200	1200	760
452553	RE.G1-080-SBL-N-SST	80	-	-	75	45	80	60	30	107	100	85	9	40	-	700	700	330
452558	RE.G1-100-SBL-N-SST	100	-	-	75	45	80	60	30	128	100	85	9	35	-	1000	1000	360
452563	RE.G1-125-SBL-N-SST	125	-	-	75	45	80	60	35	156	100	85	9	37	-	1200	1200	590
452603	RE.G1-080-SBF-N-SST	80	-	-	75	45	80	60	30	107	100	85	9	40	120	700	700	530
452608	RE.G1-100-SBF-N-SST	100	-	-	75	45	80	60	30	128	100	85	9	35	120	1000	1000	570
452613	RE.G1-125-SBF-N-SST	125	-	-	75	45	80	60	35	156	100	85	9	37	120	1200	1200	740
452703	RE.G1-080-FBL-N-SST	80	73	12	-	-	-	-	30	107	-	-	-	40	-	700	700	760
452708	RE.G1-100-FBL-N-SST	100	73	12	-	-	-	-	30	128	-	-	-	35	-	1000	1000	790
452713	RE.G1-125-FBL-N-SST	125	73	12	-	-	-	-	35	156	-	-	-	37	-	1200	1200	900
452753	RE.G1-080-FBF-N-SST	80	73	12	-	-	-	-	30	107	-	-	-	40	120	700	700	700
452758	RE.G1-100-FBF-N-SST	100	73	12	-	-	-	-	30	128	-	-	-	35	120	1000	1000	780
452763	RE.G1-125-FBF-N-SST	125	73	12	-	-	-	-	35	156	-	-	-	37	120	1200	1200	890

For rolling resistance and dynamic carrying capacity see Technical data (on page).

