

Hinged joints with clamps

Technopolymer

CLAMPS

Glass-fibre reinforced polyamide based (PA) technopolymer, RAL 9005 (C9) black colour or grey RAL 7040 (C33) colour, resistant to UV rays, matte finish.

SCREWS AND NUTS (SUPPLIED)

Cylindrical-head screw with hexagon socket in AISI 304 stainless steel with anti-seizure treatment.

Self-locking nuts in AISI 304 stainless steel.

STANDARD EXECUTIONS

- **TCC-AP-TP-T**: with teeth.
- **TCC-AP-TP-S**: without teeth.

FEATURES

Joints comprising clamps with external/internal teeth (36 teeth) have a 10° adjustment angle.

Joints comprising clamps without teeth can be positioned at any angle.

Clamps for tubes with a diameter of 30 ± 0.2 mm.

For smaller diameter tubes, the hole reduction sleeve can be used TCC-A (to be ordered separately).

The "s" grub screws may be replaced by the kit TCC-KS.

TECHNICAL DATA

The resistance values shown in the table were measured during laboratory tests at ambient temperature with the screws tightened to the suggested torque "C#".

ACCESSORIES ON REQUEST (TO BE ORDERED SEPARATELY)

- TCC-A: reduction sleeves.
- TCC-KS: clamping kit.
- GN 197: monitor mounts.
- TCC-KV: screws and clamping nuts.
- GN 990: connecting tubes.



ELESA Original design

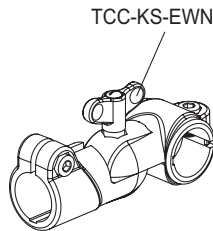
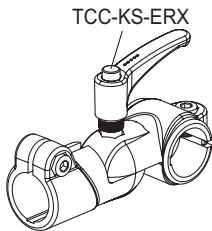
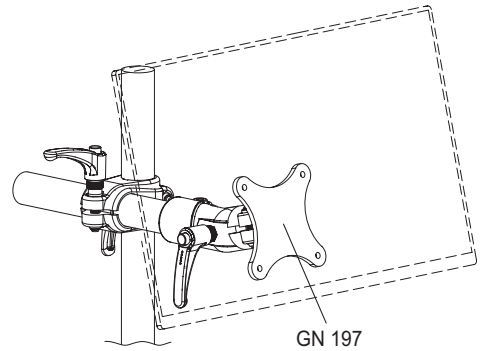

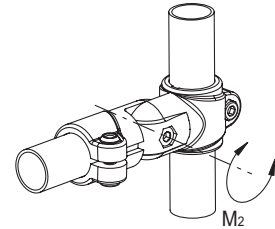
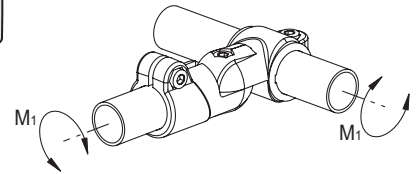
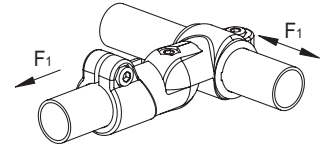
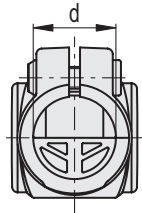
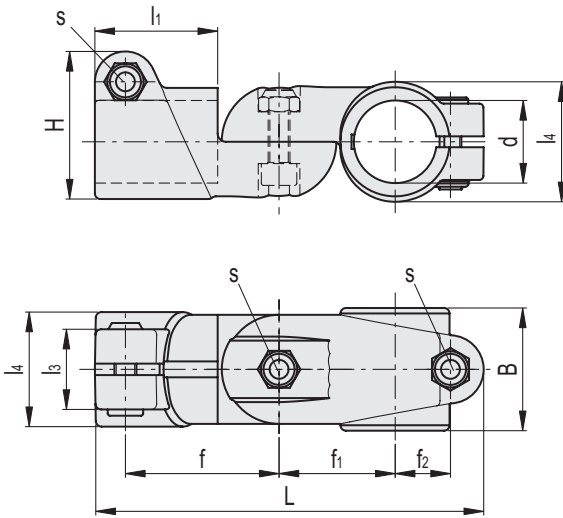

C9
 RAL9005

C33
 RAL7040

TCC-AP-TP-T

STAINLESS STEEL

Code	Description	d	L	B	H	f	f ₁	f ₂	l ₁	l ₃	l ₄	s	C# [Nm]	F1* [N]	M1** [Nm]	M2*** [Nm]		
600711-C9	TCC-AP-TP-18-T-C9	18	95.5	29	36	36.5	28.5	13.5	29.5	21	29	M6	5	900	8	44	67	
600711-C33	TCC-AP-TP-18-T-C33	18	95.5	29	36	36.5	28.5	13.5	29.5	21	29	M6	5	900	8	44	67	
600811-C9	TCC-AP-TP-30-T-C9	30	142	44.5	54	56	42	20.5	45	28	42	M8	12	3000	33	120	182	
600811-C33	TCC-AP-TP-30-T-C33	30	142	44.5	54	56	42	20.5	45	28	42	M8	12	3000	33	120	182	

TCC-AP-TP-S

STAINLESS STEEL

Code	Description	d	L	B	H	f	f ₁	f ₂	l ₁	l ₃	l ₄	s	C# [Nm]	F1* [N]	M1** [Nm]	M2*** [Nm]		
600712-C9	TCC-AP-TP-18-S-C9	18	95.5	29	36	36.5	28.5	13.5	29.5	21	29	M6	5	900	8	2	67	
600712-C33	TCC-AP-TP-18-S-C33	18	95.5	29	36	36.5	28.5	13.5	29.5	21	29	M6	5	900	8	2	67	
600812-C9	TCC-AP-TP-30-S-C9	30	142	44.5	54	56	42	20.5	45	28	42	M8	12	3000	33	4	182	
600812-C33	TCC-AP-TP-30-S-C33	30	142	44.5	54	56	42	20.5	45	28	42	M8	12	3000	33	4	182	

Suggested torque for screw assembly.

* Resistance to tube pull out

** Resistance to tube rotation

*** Resistance to joint rotation.

