

Clamps for hinged joints

Technopolymer

CLAMP

Glass-fibre reinforced polyamide based (PA) technopolymer, RAL 9005 (C9) black colour or grey RAL 7040 (C33) colour, resistant to UV rays, matte finish.

SCREWS AND NUTS

Cylindrical-head screw with hexagon socket in AISI 304 stainless steel with anti-seizure treatment.

Self-locking nuts in AISI 304 stainless steel.

Supplied: two screws and two nuts for versions TCC-AP-E and TCC-AP-S, one screw and one nut for version TCC-AP-I

STANDARD EXECUTIONS

- **TCC-AP-E**: external teeth.
- **TCC-AP-I**: internal teeth.
- **TCC-AP-S**: without teeth.

FEATURES

Two clamps, one with external teeth and one with internal teeth or two without teeth, can be joined to create a hinged joint.

Joints comprising clamps with external/internal teeth (36 teeth) have a 10° adjustment angle.

Joints comprising clamps without teeth can be positioned at any angle.

Clamps for tubes with a diameter of 30 ± 0.2 mm.

For smaller diameter tubes, the hole reduction sleeve can be used TCC-A (to be ordered separately).

The "s" grub screws may be replaced by the kit TCC-KS.

TECHNICAL DATA

The resistance values shown in the table were measured during laboratory tests at ambient temperature with the screws tightened to the maximum torque "C#".

ACCESSORIES ON REQUEST (TO BE ORDERED SEPARATELY)

- TCC-A (see page -): reduction sleeves.
- TCC-KS (see page -): clamping kit.
- GN 197 (see page -): monitor mounts.
- TCC-KV (see page -): screws and clamping nuts.
- GN 990 (see page -): connecting tubes.



ELESA Original design

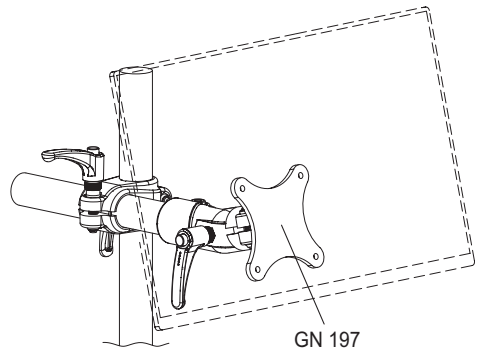

GN 197

TCC-KS-ERX

TCC-KS-EWN

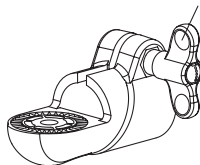
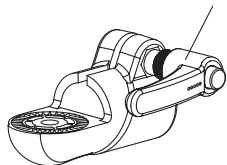



Tube connectors 16

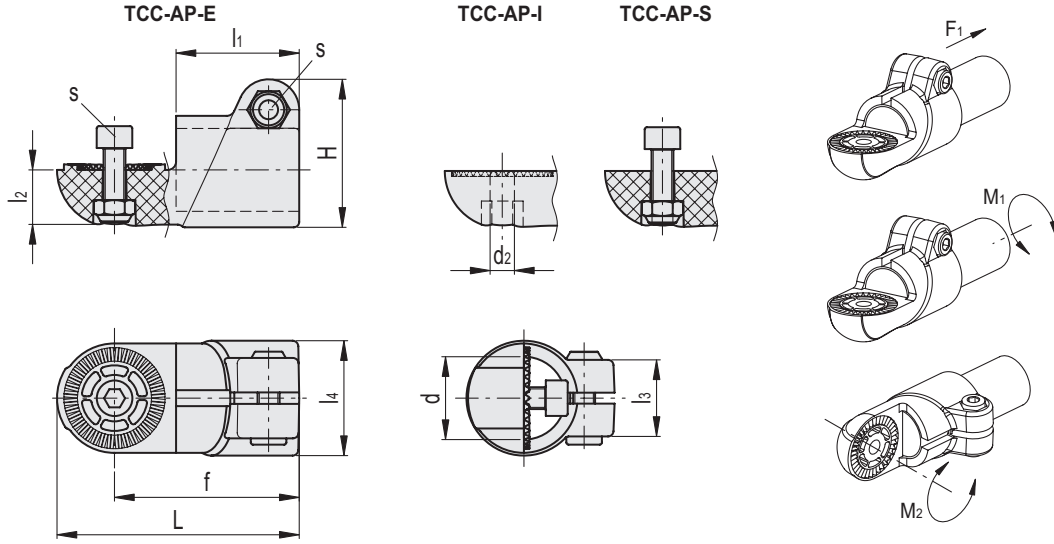

C9 RAL9005
 C33 RAL7040

TCC-AP-E

STAINLESS STEEL

Code	Description	d	L	H	d ₂	f	l ₁	l ₂	l ₃	l ₄	s	C# [Nm]	F1* [N]	M1** [Nm]	M2*** [Nm]	⚖
600301-C9	TCC-AP-18-E-C9	18	59	36	6.5	45	29.5	13	21	29	M6	5	900	8	44	37
600301-C33	TCC-AP-18-E-C33	18	59	36	6.5	45	29.5	13	21	29	M6	5	900	8	44	37
600401-C9	TCC-AP-30-E-C9	30	88	54	8.5	67.5	45	20	28	42	M8	12	3300	33	140	98
600401-C33	TCC-AP-30-E-C33	30	88	54	8.5	67.5	45	20	28	42	M8	12	3300	33	140	98

TCC-AP-I

STAINLESS STEEL

Code	Description	d	L	H	d ₂	f	l ₁	l ₂	l ₃	l ₄	s	C# [Nm]	F1* [N]	M1** [Nm]	M2*** [Nm]	⚖
600303-C9	TCC-AP-18-I-C9	18	59	36	6.5	45	29.5	13	21	29	M6	5	900	8	44	37
600303-C33	TCC-AP-18-I-C33	18	59	36	6.5	45	29.5	13	21	29	M6	5	900	8	44	37
600403-C9	TCC-AP-30-I-C9	30	88	54	8.5	67.5	45	20	28	42	M8	12	3300	33	140	98
600403-C33	TCC-AP-30-I-C33	30	88	54	8.5	67.5	45	20	28	42	M8	12	3300	33	140	98

TCC-AP-S

STAINLESS STEEL

Code	Description	d	L	H	d ₂	f	l ₁	l ₂	l ₃	l ₄	s	C# [Nm]	F1* [N]	M1** [Nm]	M2*** [Nm]	⚖
600305-C9	TCC-AP-18-S-C9	18	59	36	6.5	45	29.5	13	21	29	M6	5	900	8	2	37
600305-C33	TCC-AP-18-S-C33	18	59	36	6.5	45	29.5	13	21	29	M6	5	900	8	2	37
600405-C9	TCC-AP-30-S-C9	30	88	54	8.5	67.5	45	20	28	42	M8	12	3300	33	6	98
600405-C33	TCC-AP-30-S-C33	30	88	54	8.5	67.5	45	20	28	42	M8	12	3300	33	6	98

Suggested torque for screw assembly.

* Resistance to tube pull out

** Resistance to tube rotation

*** Resistance to joint rotation.