

## Push-fit caps

with elastic fork, fill symbol, technopolymer

### MATERIAL

Polyamide-based (PA) technopolymer, black colour RAL 9005, matte finish.

### ELASTIC FORK

Acetal-based technopolymer (POM), black colour.

### PACKING RINGS

Two NBR synthetic rubber O-rings.

### STANDARD EXECUTIONS

- **TP-C-RC**: without side hole.
- **TP-CF-RC**: with side breather hole.

### MAXIMUM CONTINUOUS WORKING TEMPERATURE

60°C.

### GRAPHIC SYMBOL "FILL"

According to DIN regulations.

### MOUNTING

Push-fit avoids the need to screw/unscrew.

### FEATURES AND APPLICATIONS

Suitable for use when it is necessary to avoid the loss of the cap. The elastic fork, housed in the special groove of the cap, can rotate freely.

### ACCESSORIES ON REQUEST

- CT-S technopolymer and stainless steel ball chains (see page-).
- GN 111 stainless steel and brass ball chains (see page-).
- CV-T polyethylene and stainless steel retaining cables (see page-).
- GN 111.2 stainless steel retaining cables (see page-).
- GN 111.4 polyurethane and stainless steel spiral retaining cables (see page-).
- GN 111.8 AISI 316 stainless steel retaining cables (see page-).



ELESA Original design

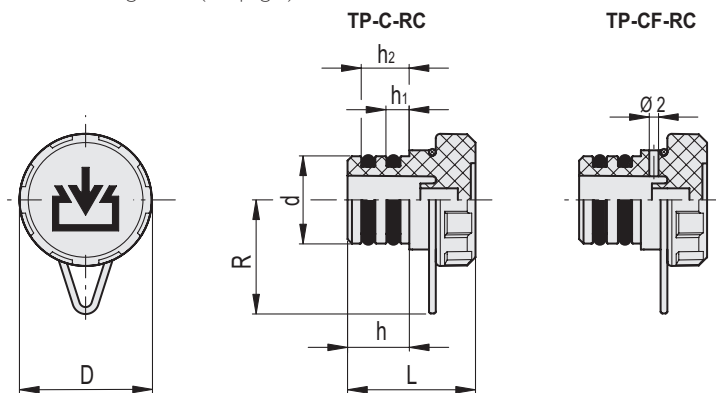

### TP-C-RC

Code	Description	D	d	h	L	R	h <sub>1</sub>	h <sub>2</sub>	Mounting hole d+0.2	
60501-C9	TP-C.12-RC-C9	20	12	11	26	20.5	4	8	12	10
60503-C9	TP-C.18-RC-C9	26	18	13	28	22.5	4.5	10	18	15
60511-C9	TP-C.20-RC-C9	30	20	14	29	24	5	11	20	18
60531-C9	TP-C.26-RC-C9	35	26	14	29.5	26.5	5	11	26	26

### TP-CF-RC

Code	Description	D	d	h	L	R	h <sub>1</sub>	h <sub>2</sub>	Mounting hole d+0.2	
60541-C9	TP-CF.12-RC-C9	20	12	11	26	20.5	4	8	12	10
60543-C9	TP-CF.18-RC-C9	26	18	13	28	22.5	4.5	10	18	12
60551-C9	TP-CF.20-RC-C9	30	20	14	29	24	5	11	20	18
60571-C9	TP-CF.26-RC-C9	35	26	14	29.5	26.5	5	11	26	26