

Lobe knobs

with retaining chain, technopolymer

MATERIAL

High-resilience polypropylene based (PP) technopolymer, black colour, matte finish.

Technopolymer centre cap, black colour, matte finish. Not available for VCT.25.

Elastic fork in acetal based technopolymer (POM), black colour.

RETAINING CHAIN

Ball cable and coupling heads in acetal resin based (POM) technopolymer, black colour.

NERINOX treated stainless steel ring with two coils.

Head fastening by means of a self-tapping screw $\varnothing 4.8$ mm UNI EN ISO 7050 or a M5 countersunk-head screw UNI EN ISO 10642.

STANDARD EXECUTION

- **VCT-B-LP**: brass boss, threaded pass-through hole.

- **VCT-p-LP**: zinc-plated steel threaded stud chamfered flat end according to UNI 947: ISO 4753 (see Technical data on page -).

FEATURES AND APPLICATIONS

The elastic fork, housed in the groove of the knob can turn freely. The coiled ring connects the fork to the chain.

Suitable where it is necessary to prevent the loss of the knob.

SPECIAL EXECUTIONS ON REQUEST

- Chain in different lengths.

- Knob with retaining cable CV-T (see page -) in polyethylene black colour.

- Knob with stainless steel cable GN 111 (see page -), GN 111.2 (see page -) and GN 111.4 (see page -).



ELESA Original design

VCT-B-LP

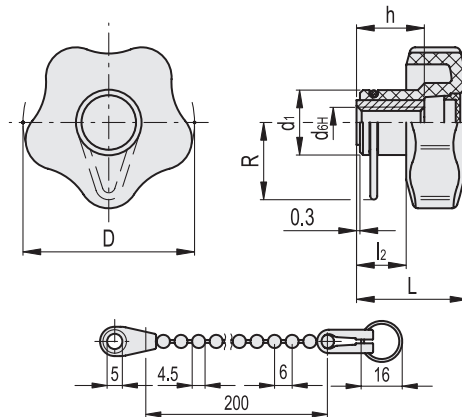

VCT-B-LP

Code	Description	D	d6H	L	d1	l2	h	R	C# [Nm]	⚖️
69512-C9	VCT.25 B-M5-LP-C9	25	M5	19	13	8	10	20	7	15
69544-C9	VCT.32 B-M6-LP-C9	32	M6	23	15	10	12	21	10	17
69594-C9	VCT.40 B-M8-LP-C9	40	M8	27	17	12	18	21.5	18	24
69654-C9	VCT.50 B-M10-LP-C9	50	M10	32	19	14	20	22.5	27	36
69714-C9	VCT.63 B-M12-LP-C9	63	M12	37	22	16	26	24	50	49

"Max limit Tightening torque" means the max torque value at which the metal insert, in normal conditions of use, is perfectly and strongly anchored to the plastic material.

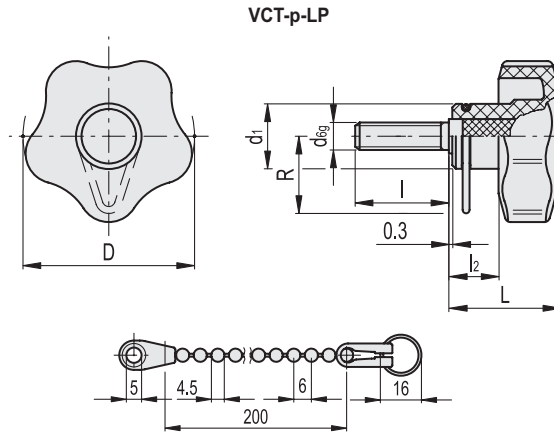

VCT-p-LP

Code	Description	D	d6g	L	d1	l	l2	R	C# [Nm]	⚖️
69521-C9	VCT.25 p-M5x10-LP-C9	25	M5	19	13	10	8	20	6	15
69522-C9	VCT.25 p-M5x16-LP-C9	25	M5	19	13	16	8	20	6	16
69523-C9	VCT.25 p-M5x20-LP-C9	25	M5	19	13	20	8	20	6	17
69524-C9	VCT.25 p-M5x25-LP-C9	25	M5	19	13	25	8	20	6	9
69551-C9	VCT.32 p-M6x16-LP-C9	32	M6	23	15	16	10	21	8	20
69552-C9	VCT.32 p-M6x20-LP-C9	32	M6	23	15	20	10	21	8	20
69553-C9	VCT.32 p-M6x25-LP-C9	32	M6	23	15	25	10	21	8	22
69554-C9	VCT.32 p-M6x30-LP-C9	32	M6	23	15	30	10	21	8	22
69612-C9	VCT.40 p-M8x20-LP-C9	40	M8	27	17	20	12	21.5	16	31
69613-C9	VCT.40 p-M8x25-LP-C9	40	M8	27	17	25	12	21.5	16	33
69614-C9	VCT.40 p-M8x30-LP-C9	40	M8	27	17	30	12	21.5	16	34
69616-C9	VCT.40 p-M8x40-LP-C9	40	M8	27	17	40	12	21.5	16	37
69671-C9	VCT.50 p-M10x20-LP-C9	50	M10	32	19	20	14	22.5	23	44
69672-C9	VCT.50 p-M10x25-LP-C9	50	M10	32	19	25	14	22.5	23	47
69673-C9	VCT.50 p-M10x30-LP-C9	50	M10	32	19	30	14	22.5	23	49
69675-C9	VCT.50 p-M10x40-LP-C9	50	M10	32	19	40	14	22.5	23	54
69733-C9	VCT.63 p-M12x30-LP-C9	63	M12	37	22	30	16	24	46	74
69735-C9	VCT.63 p-M12x40-LP-C9	63	M12	37	22	40	16	24	46	81
69736-C9	VCT.63 p-M12x50-LP-C9	63	M12	37	22	50	16	24	46	70

"Max limit Tightening torque" means the max torque value at which the metal insert, in normal conditions of use, is perfectly and strongly anchored to the plastic material.