

## Solid handwheels

### Duroplast, stainless steel hub

#### MATERIAL

High-strength, reinforced phenolic based (PF) Duroplast, black colour, glossy finish.

#### RING

Matte anodised aluminium.  
(ELESA Original design - Reg. U.S. Pat. & TM Off.)

#### STANDARD EXECUTIONS

AISI 303 stainless steel hub with H7 reamed hole.  
H9 reamed hole for executions with keyway.

- **VDN.FP-SST-A**: without handle.  
- **VDN.FP+I-SST-A**: with revolving handle l.301+x (see page ) in Duroplast.

- **K**: index for executions with hole and keyway in compliance with DIN 6885/1 (see page A16), tolerance P9 i.e.:  
73695-10-K VDN.80 FP-SST-A-10-K

AISI 303 stainless steel hub not drilled in order to make holes different from the standard:

- **VDN.FP-SST**: without handle.  
- **VDN.FP+I-SST**: with revolving handle l.301+x (see page ) in Duroplast.

#### SPECIAL EXECUTIONS ON REQUEST

Handwheels with incorporated balancing counterweights.

#### ACCESSORIES ON REQUEST

Axial retaining washer in AISI 303 stainless steel GN 184.5 (see page ).

#### ERGONOMY

The rim with internal rear scallops makes the grip and the manoeuvre of the handwheel easier.



ELESA Original design

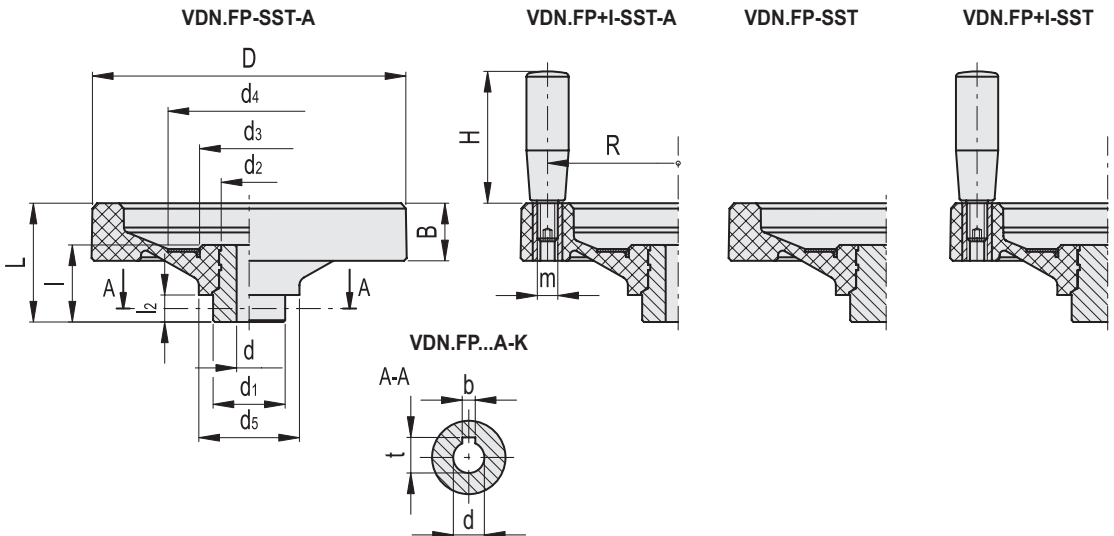
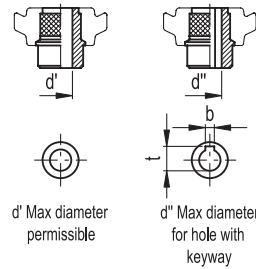



Operating elements 1

**VDN.FP-SST-A**

**STAINLESS STEEL**

Code	Description	D	dH7	L	B	d1	d2	d3	d4	d5	l	l2	d'	d''	t	b	C# [Nm]	L# [J]	⚖️
73695-10	VDN.80 FP-SST-A10	80	10	31	14	20	18	28	43	30	28	10	13	11	12.8	4	120	5	120
73695-12	VDN.80 FP-SST-A12	80	12	31	14	20	18	28	43	30	28	10	13	11	12.8	4	120	5	115
73713-10	VDN.100 FP-SST-A10	100	10	40	15	24	22	35	54	39	36	12	16	13	15.3	5	150	6	324
73713-12	VDN.100 FP-SST-A12	100	12	40	15	24	22	35	54	39	36	12	16	13	15.3	5	150	6	322
73722-12	VDN.125 FP-SST-A12	125	12	44	15	32	26.5	44	70	46	38	15	20	16	18.3	5	300	8	493
73722-14	VDN.125 FP-SST-A14	125	14	44	15	32	26.5	44	70	46	38	15	20	16	18.3	5	300	8	490
73733-14	VDN.150 FP-SST-A14	150	14	49	18	32	26.5	44	70	48	38	15	20	16	18.3	5	400	14	662
73733-16	VDN.150 FP-SST-A16	150	16	49	18	32	26.5	44	70	48	38	15	20	16	18.3	5	400	14	659
73753-18	VDN.200 FP-SST-A18	200	18	58	22	40	33	55	90	60	43	15	26	22	24.8	6	600	18	1196
73753-20	VDN.200 FP-SST-A20	200	20	58	22	40	33	55	90	60	43	15	26	22	24.8	6	600	18	1192
73773-22	VDN.250 FP-SST-A22	249	22	65	25	49	40	66	110	70	44	15	35	27	30.3	8	1000	28	1982
73773-24	VDN.250 FP-SST-A24	249	24	65	25	49	40	66	110	70	44	15	35	27	30.3	8	1000	28	1982
73785-26	VDN.300 FP-SST-A26	301	26	75	25	58	58	94	148	82	56	18	42	38	41.3	10	1100	35	2685

**VDN.FP+I-SST-A**

**STAINLESS STEEL**

Code	Description	D	dH7	L	B	d1	d2	d3	d4	d5	l	l2	H	m	R	d'	d''	t	b	C# [Nm]	L# [J]	⚖️
73715-10	VDN.100 FP+I-SST-A10	100	10	46	21	24	20	35	54	39	33.5	12	50	M6	39	16	13	15.3	5	150	6	361
73715-12	VDN.100 FP+I-SST-A12	100	12	46	21	24	20	35	54	39	33.5	12	50	M6	39	16	13	15.3	5	150	6	358
73725-12	VDN.125 FP+I-SST-A12	125	12	57	28	32	26.5	44	70	46	38	15	65	M8	50	20	16	18.3	5	300	8	568
73725-14	VDN.125 FP+I-SST-A14	125	14	57	28	32	26.5	44	70	46	38	15	65	M8	50	20	16	18.3	5	300	8	565
73735-14	VDN.150 FP+I-SST-A14	150	14	61	30	32	26.5	50	80	48	38	15	65	M8	62	20	16	18.3	5	400	14	737
73735-16	VDN.150 FP+I-SST-A16	150	16	61	30	32	26.5	50	80	48	38	15	65	M8	62	20	16	18.3	5	400	14	734
73755-18	VDN.200 FP+I-SST-A18	200	18	68	32	40	33	55	90	60	43	15	90	M10	82	26	22	24.8	6	600	18	1314
73755-20	VDN.200 FP+I-SST-A20	200	20	68	32	40	33	55	90	60	43	15	90	M10	82	26	22	24.8	6	600	18	1308
73775-22	VDN.250 FP+I-SST-A22	249	22	76	36	49	40	66	110	70	44.5	15	90	M10	106	35	27	30.3	8	1000	28	2100
73775-24	VDN.250 FP+I-SST-A24	249	24	76	36	49	40	66	110	70	44.5	15	90	M10	106	35	27	30.3	8	1000	28	2097
73786-26	VDN.300 FP+I-SST-A26	301	26	87	36	58	58	94	148	82	56	18	90	M10	132	42	38	41.3	10	1100	35	2803

**VDN.FP-SST**

**STAINLESS STEEL**

Code	Description	D	L	B	d1	d2	d3	d4	d5	l	l2	d'	d''	t	b	C# [Nm]	L# [J]	⚖️
73695	VDN.80 FP-SST	80	31	14	20	18	28	43	30	28	10	13	11	12.8	4	120	5	146
73713	VDN.100 FP-SST	100	40	15	24	22	35	54	39	36	12	16	13	15.3	5	150	6	263
73722	VDN.125 FP-SST	125	44	15	32	26.5	44	70	46	38	15	20	16	18.3	5	300	8	389
73733	VDN.150 FP-SST	150	49	18	32	26.5	44	70	48	38	15	20	16	18.3	5	400	14	528
73753	VDN.200 FP-SST	200	58	22	40	33	55	90	60	43	15	26	22	24.8	6	600	18	989
73773	VDN.250 FP-SST	249	65	25	49	40	66	110	70	44	15	35	27	30.3	8	1000	28	1728
73785	VDN.300 FP-SST	301	75	25	58	58	94	148	82	56	18	42	38	41.3	10	1100	35	2978

**VDN.FP+I-SST**

**STAINLESS STEEL**

Code	Description	D	L	B	d1	d2	d3	d4	d5	l	l2	H	m	R	d'	d''	t	b	C# [Nm]	L# [J]	⚖️
73715	VDN.100 FP+I-SST	100	46	21	24	20	35	54	39	33.5	12	50	M6	39	16	13	15.3	5	150	6	309
73725	VDN.125 FP+I-SST	125	57	28	32	26.5	44	70	46	38	15	65	M8	50	20	16	18.3	5	300	8	564
73735	VDN.150 FP+I-SST	150	61	30	32	26.5	50	80	48	38	15	65	M8	62	20	16	18.3	5	400	14	711
73755	VDN.200 FP+I-SST	200	68	32	40	33	55	90	60	43	15	90	M10	82	26	22	24.8	6	600	18	1248
73775	VDN.250 FP+I-SST	249	76	36	49	40	66	110	70	44.5	15	90	M10	106	35	27	30.3	8	1000	28	2144
73786	VDN.300 FP+I-SST	301	87	36	58	58	94	148	82	56	18	90	M10	132	42	38	41.3	10	1100	35	3249

\* To order the execution with hole and keyway add the index -K after the code and description (i.e. 73695-10-K VDN.80 FP-SST-A-10-K).

# For maximum torque (C) and impact strength (L) see Technical Data on page A3.