

## Handwheels for positions indicators

### Technopolymer

#### MATERIAL

Glass-fibre reinforced polyamide based (PA) technopolymer, black colour, matte finish.

#### STANDARD EXECUTION

Boss H7 reamed through hole.

- **VDSC-GXX+I:** with revolving handle I.621+x (see page ) in polyamide based (PA) technopolymer, black colour, matte finish. Black-oxide steel boss.

- **VDSC-GXX-SST+I:** with revolving handle I.621+x-SST (see page ) in polyamide based (PA) technopolymer, black colour, matte finish. AISI 303 stainless steel boss.

- **VDSC-GXX+IR:** with fold-away handle IR.620 (see page ) in polyamide based (PA) technopolymer, black colour, matte finish. Black-oxide steel boss.

- **VDSC-GXX-SST+IR:** with fold-away handle IR.620-SST (see page ) in polyamide based (PA) technopolymer, black colour, matte finish.

AISI 303 stainless steel boss.

#### INDICATOR CHOICE (TO BE ORDERED SEPARATELY)

VDSC-XX solid handwheels can be used with analogue and digital-analogue gravity indicators.

To choose the indicator see the table below for possible assembly with indicators.

See also "Assembly instructions" for gravity indicators type G (on page ).

#### ACCESSORIES ON REQUEST

Cover CP-XX (see page ) for fitting instead of the indicator.



ELESA Original design

VDSC-GXX+I  
VDSC-GXX-SST+I

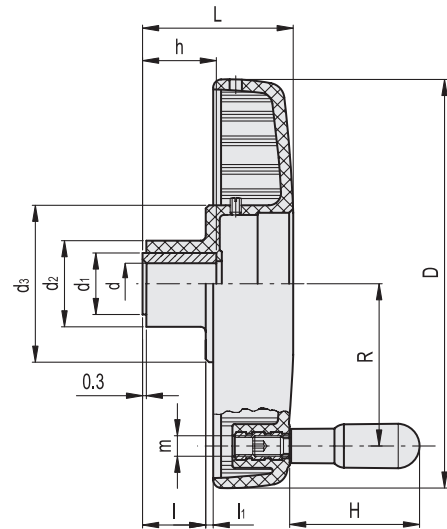

#### VDSC-GXX+I

Code	Description	D	L	dH7	h	d1	d2	d3	I	li	H	m	R	⚖️	Handwheel indicator combinations
CE.34015	VDSC.125-GXX2 A-8+I	125	63	8	22	22	35	76	22	14	65	M8	48.5	292	GA02 - GA12 - GW12
CE.34021	VDSC.125-GXX2 A-10+I	125	63	10	22	22	35	76	22	14	65	M8	48.5	290	GA02 - GA12 - GW12
CE.34061	VDSC.160-GXX2 A-10+I	160	66.5	10	30	26	38	77	26	7.5	74	M8	63	650	GA02 - GA12 - GW12
CE.34065	VDSC.160-GXX2 A-14+I	160	66.5	14	36	40	38	77	26	7.5	74	M8	63	650	GA02 - GA12 - GW12
CE.34075	VDSC.200-GXX2 A-16+I	200	70.5	16	34	30	42	76	30	2	90	M10	80	684	GA02 - GA12 - GW12
CE.34081	VDSC.200-GXX2 A-20+I	200	70.5	20	34	30	42	76	30	2	90	M10	80	680	GA02 - GA12 - GW12

#### VDSC-GXX+I-SST

#### STAINLESS STEEL

Code	Description	D	L	dH7	h	d1	d2	d3	I	li	H	m	R	⚖️	Handwheel indicator combinations
CE.34017	VDSC.125-GXX2 SST-8+I	125	63	8	22	22	35	76	22	14	65	M8	48.5	293	GA02 - GA12 - GW12
CE.34023	VDSC.125-GXX2 SST-10+I	125	63	10	22	22	35	76	22	14	65	M8	48.5	291	GA02 - GA12 - GW12
CE.34077	VDSC.200-GXX2 SST-16+I	200	70.5	16	34	30	42	76	30	2	90	M10	80	685	GA02 - GA12 - GW12
CE.34083	VDSC.200-GXX2 SST-20+I	200	70.5	20	34	30	42	76	30	2	90	M10	80	681	GA02 - GA12 - GW12



Rotary controls 7

VDSC-GXX+IR  
VDSC-GXX-SST+IR

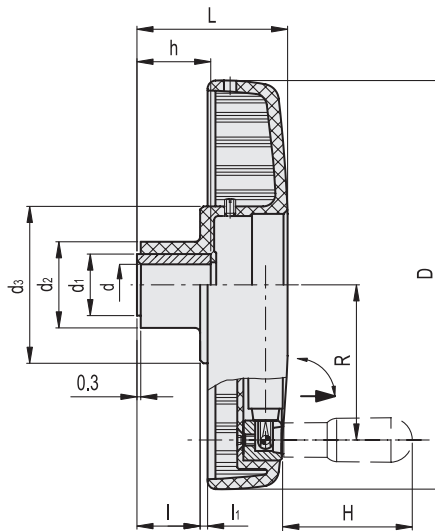

VDSC-GXX+IR

Code	Description	D	L	dH7	h	d1	d2	d3	I	li	H	R	⚖	Handwheel indicator combinations
CE.34001	VDSC.125-GXX1 A-8+IR	125	63	8	22	22	35	76	22	14	45	47	322	GA01 - GA11
CE.34005	VDSC.125-GXX1 A-10+IR	125	63	10	22	22	35	76	22	14	45	47	321	GA01 - GA11
CE.34045	VDSC.160-GXX2 A-10+IR	160	66	10	30	26	38.5	77	25.5	7.5	60	63	437	GA02 - GA12 - GW12
CE.34051	VDSC.160-GXX2 A-12+IR	160	66	12	30	26	38.5	77	25.5	7.5	60	63	435	GA02 - GA12 - GW12
CE.34085	VDSC.200-GXX2 A-16+IR	200	77	16	36	40	49	77	35	4	80	77	784	GA02 - GA12 - GW12
CE.34091	VDSC.200-GXX2 A-20+IR	200	77	20	36	40	49	77	35	4	80	77	780	GA02 - GA12 - GW12

VDSC-GXX-SST+IR

STAINLESS STEEL

Code	Description	D	L	dH7	h	d1	d2	d3	I	li	H	R	⚖	Handwheel indicator combinations
CE.34003	VDSC.125-GXX1 SST-8+IR	125	63	8	22	22	35	76	22	14	45	47	324	GA01 - GA11
CE.34007	VDSC.125-GXX1 SST-10+IR	125	63	10	22	22	35	76	22	14	45	47	323	GA01 - GA11
CE.34047	VDSC.160-GXX2 SST-10+IR	160	66	10	30	26	38.5	77	25.5	7.5	60	63	438	GA02 - GA12 - GW12
CE.34053	VDSC.160-GXX2 SST-12+IR	160	66	12	30	26	38.5	77	25.5	7.5	60	63	436	GA02 - GA12 - GW12
CE.34087	VDSC.200-GXX2 SST-16+IR	200	77	16	36	40	49	77	35	4	80	77	785	GA02 - GA12 - GW12
CE.34093	VDSC.200-GXX2 SST-20+IR	200	77	20	36	40	49	77	35	4	80	77	781	GA02 - GA12 - GW12