

Safety lobe knobs

Technopolymer

LOBE SOLID CAP

Glass-fibre reinforced polyamide based (PA) technopolymer, black colour, matte finish, with security anti-intrusion-profiled key slot.

FLANGE

Technopolymer, ultrasonically welded.

CLAMPING ELEMENT

Acetal resin based (POM) technopolymer, black colour, matte finish.

STANDARD EXECUTIONS

- **VLS-B**: brass boss, threaded blind hole.
- **VLS-SST-p**: AISI 304 stainless steel threaded stud, chamfered flat end according to UNI 947 : ISO 4753 (see Technical data).

SECURITY KEY (TO BE ORDERED SEPARATELY)

- CSN acetal resin based (POM) technopolymer fold-away key, red colour, anti-intrusion-profiled stainless steel insert.
- CSF polyamide based (PA) technopolymer ball key, red colour, anti-intrusion-profiled stainless steel insert.

On request and for sufficient quantities the security keys can be supplied in black colour too.

SECURITY DEVICE OPERATION

VLS. security lobe knobs have been designed to be unscrewed only by authorised people, provided with the security key. Without the security key, the knob turns without unscrewing.

1. Clamping: clamp the knob by screwing it as for a normal knob. Mind that the security key is not inserted.
2. Unscrewing: simply insert the security key (without turning it) and unscrew the knob.

FEATURES AND APPLICATIONS

The particular design of the internal device and of the flange helps the drainage of any dirt (dust, earth, liquid).



ELESA Original design

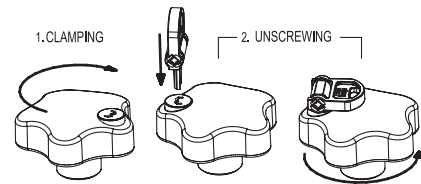
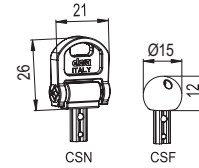

VLS-B

VLS-SST-p

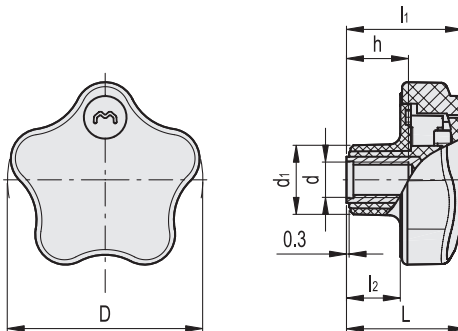

VLS-B

Code	Description	D	d6H	L	d1	l1	l2	h	⚖
76501	VLS.42 B-M6	41.5	M6	30	16.5	29.5	14.5	12	25
76502	VLS.42 B-M8	41.5	M8	30	16.5	29.5	14.5	13	26
76551	VLS.55 B-M8	55	M8	33	19	32	15	13	33
76552	VLS.55 B-M10	55	M10	33	19	32	15	17	35

VLS-SST-p

STAINLESS STEEL

Code	Description	D	d6g	L	d1	l	l1	l2	⚖
76521	VLS.42-SST-p-M8x16	41.5	M8	30	16.5	16	29.5	14.5	36
76523	VLS.42-SST-p-M8x25	41.5	M8	30	16.5	25	29.5	14.5	40
76621	VLS.55-SST-p-M10x20	55	M10	33	19	20	32	15	44
76625	VLS.55-SST-p-M10x40	55	M10	33	19	40	32	15	52