

Bellows vacuum cups for food packaging

Diameter 75 mm, with or without support, rubber

MATERIAL

Vacuum cup in oil-proof rubber (NBR), natural (NR), or silicone (VMQ).

Support in anodised aluminium.

STANDARD EXECUTIONS

- **VVL-75-A**: oil-proof rubber, without support.
- **VVL-75-N**: natural rubber, without support.
- **VVL-75-S**: silicone rubber, without support.
- **VVL-75-T-A**: oil-proof rubber, with support.
- **VVL-75-T-N**: natural rubber, with support.
- **VVL-75-T-S**: silicone rubber, with support.

FEATURES AND APPLICATIONS

The internal surface of the vacuum cup provides a better grip even with products that have irregular or inclined surfaces.

They are specifically used in the food packaging sector where the size and the shape of the vacuum cup allow the handling of different shaped and sized packages. The adaptability to different surfaces, including irregular ones or with imperfect flatness, mean that these vacuum cups are suitable for use in various sectors including paper processing for trading cards, labels and sheets of paper and the plastic sector for laminates and small parts.

The effective stroke of the bellows is 24 mm.

See Technical Data for vacuum cups (on page -).

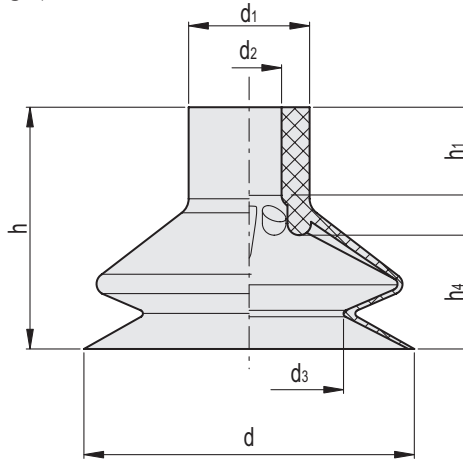

VVL-75-A

Code	Description	d	d1	d2	d3	h	h1	h4	F* [Kg]	Volume # [cm3]	⚖
VV.56066	VVL-75-A	75	27	11	43	54	20	24	11	63	37

VVL-75-N

Code	Description	d	d1	d2	d3	h	h1	h4	F* [Kg]	Volume # [cm3]	⚖
VV.56067	VVL-75-N	75	27	11	43	54	20	24	11	63	37

VVL-75-S

Code	Description	d	d1	d2	d3	h	h1	h4	F* [Kg]	Volume # [cm3]	⚖
VV.56068	VVL-75-S	75	27	11	43	54	20	24	11	63	37

* The force of the vacuum cups indicated in the table represents 1/3 of the value of the theoretical force calculated at a vacuum level of -75 KPa and a safety coefficient of 3.

Indicates the internal geometric volume of the vacuum cup and represents the volume to be added to the entire distribution circuit for the calculation of the evacuation time, especially if multiple vacuum cups are used.

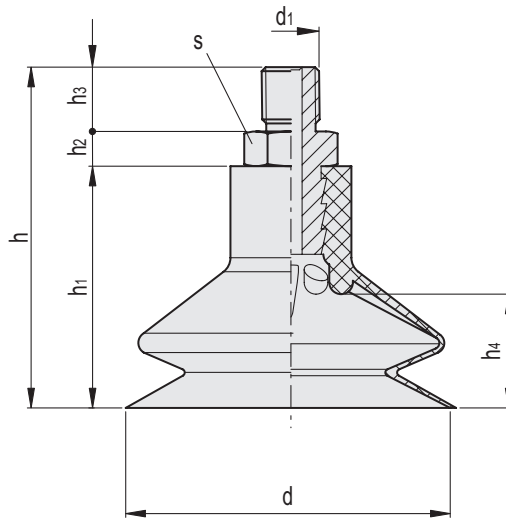

VVL-75-T-A

Code	Description	d	d1	h	h1	h2	h3	h4	s	F* [Kg]	Volume # [cm3]	⚖
VV.56069	VVL-75-G1/4-T-A	75	G1/4	76	54	8	14	24	17	11	63	49

VVL-75-T-N

Code	Description	d	d1	h	h1	h2	h3	h4	s	F* [Kg]	Volume # [cm3]	⚖
VV.56070	VVL-75-G1/4-T-N	75	G1/4	76	54	8	14	24	17	11	63	49

VVL-75-T-S

Code	Description	d	d1	h	h1	h2	h3	h4	s	F* [Kg]	Volume # [cm3]	⚖
VV.56071	VVL-75-G1/4-T-S	75	G1/4	76	54	8	14	24	17	11	63	49

* The force of the vacuum cups indicated in the table represents 1/3 of the value of the theoretical force calculated at a vacuum level of -75 KPa and a safety coefficient of 3.

Indicates the internal geometric volume of the vacuum cup and represents the volume to be added to the entire distribution circuit for the calculation of the evacuation time, especially if multiple vacuum cups are used.