

Round vacuum cups with double bellows

Diameter 50 mm, with support, vulcanised rubber

MATERIAL

Vacuum cup in oil-proof rubber (NBR), natural (NR), or silicone (VMQ).
Support in anodised aluminium.

STANDARD EXECUTIONS

- **VVP-50-T-A**: oil-proof rubber.
- **VVP-50-T-N**: natural rubber.
- **VVP-50-T-S**: silicone rubber.

FEATURES AND APPLICATIONS

They are specifically indicated for picking up thin sheet metal or glass sheets.

The vacuum cup has a vulcanised treatment which makes it more resistant to abrasion and wear and above all to traction forces, as well as allowing the rubber to degrade less easily making it more resistant to aggressive environmental agents and extending the length of its useful life.

The multi-bellows configuration makes the vacuum cup suitable for different surfaces, even irregular ones, with imperfect flatness or inclined, allowing its use in different applications including the handling of wooden panels (chipboard or pressed) or plastic laminates.

The effective stroke of the bellows is 24 mm.

See Technical Data for vacuum cups (on page -).

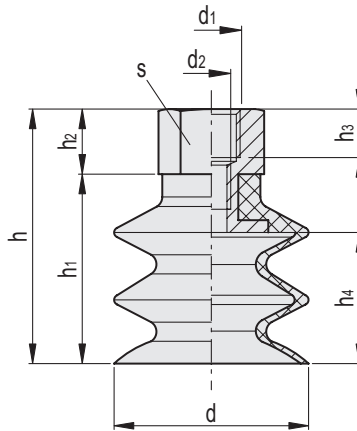

VVP-50-T-A

Code	Description	d	d1	d2	h	h1	h2	h3	h4	s	F* [Kg]	Volume # [cm3]	⚖️
VV.60504	VVP-50-G1/4-T-A	50	G1/4	M8	72	55	17	13	38	20	4.90	41.6	50

VVP-50-T-N

Code	Description	d	d1	d2	h	h1	h2	h3	h4	s	F* [Kg]	Volume # [cm3]	⚖️
VV.60505	VVP-50-G1/4-T-N	50	G1/4	M8	72	55	17	13	38	20	4.90	41.6	50

VVP-50-T-S

Code	Description	d	d1	d2	h	h1	h2	h3	h4	s	F* [Kg]	Volume # [cm3]	⚖️
VV.60506	VVP-50-G1/4-T-S	50	G1/4	M8	72	55	17	13	38	20	4.90	41.6	50

* The force of the vacuum cups indicated in the table represents 1/3 of the value of the theoretical force calculated at a vacuum level of -75 KPa and a safety coefficient of 3.

Indicates the internal geometric volume of the vacuum cup and represents the volume to be added to the entire distribution circuit for the calculation of the evacuation time, especially if multiple vacuum cups are used.